

PORTA-DOCK, INC.

65A 1155 DOUBLE PERSONAL WATERCRAFT LIFT

Thank you for purchasing our product!
Please read these instructions and follow them step by step.*

STEP 1. Separate and group like parts and fasteners together. Locate the four leveling legs with pads (**REF. # 1**) and the two side members (**REF. # 2 & 3**) slide the four leveling legs into the end upright tubes of the side members, leaving approximately 4 inches sticking out. Secure in place with 1/2" X 1" set screws (**REF. # 36**). Set the side members approximately 113" apart and make sure the rear gusset plate is to the outside and the small flat tabs on the bottom side tube are to the inside.

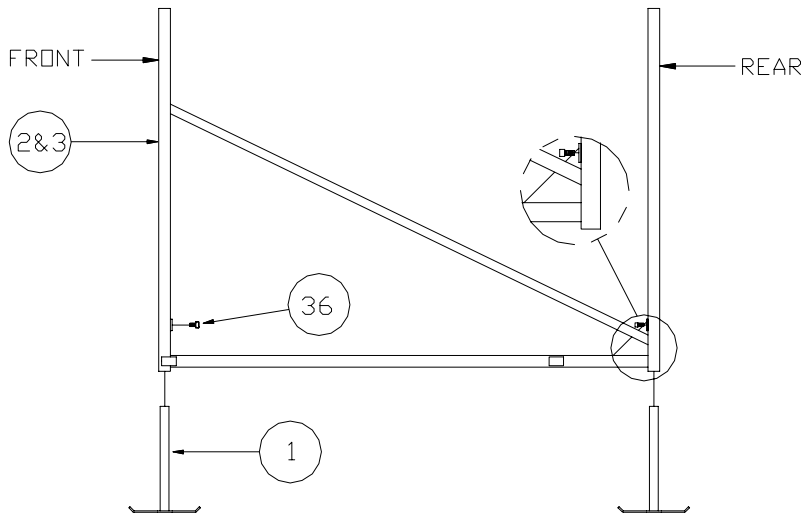

STEP 2. Find the two bottom cross bar tubes (**REF. # 4**) (They're the ones with the end plates and channels welded on). Before bolting the cross bars in place put a 1/2" X 8" bolt and washer (**REF. # 40 & 20**) through the center hole from the bottom side as shown in step 2B and temporarily hold in place with "1/2" nuts. With the channels facing to the rear of the lift set them between the two side members so that the end plate is up against the end of the tabs that are welded on the bottom side tube. These bolts will be used in the next step. Fasten the bottom cross bar to the bottom tube of the side with the eight square U-bolts and flange nuts (**REF. # 16 & 17**). **Finger** tighten nuts. Using a tape measure, square the four corners of the uprights so that it is within about a 1/4" Tighten all U-bolt nuts.

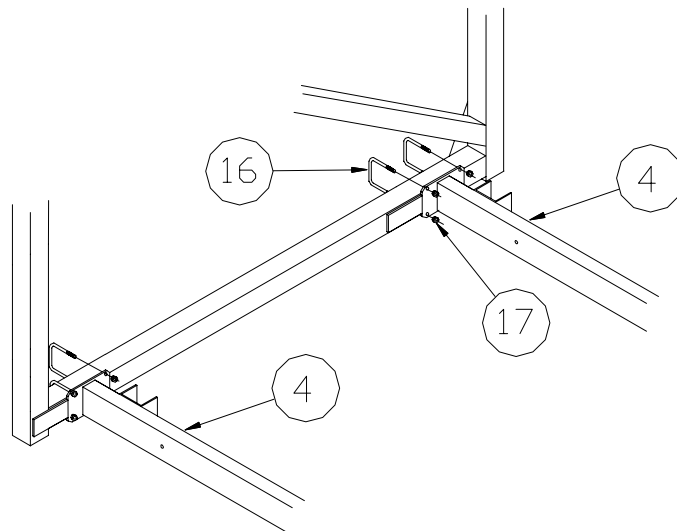

STEP 2B. Remove the 1/2" nuts on the 1/2" X 8" bolts (REF. # 40) that were installed in step 2 and place the center side member (REF. # 11) onto the bolts, and secure with 1/2" washers and nuts (REF. # 20 & 34). Place plastic caps (REF. # 37) on the upright and bottom end of the center side member. If not installing a canopy place the two remaining caps on the rear uprights of the outside side sections.

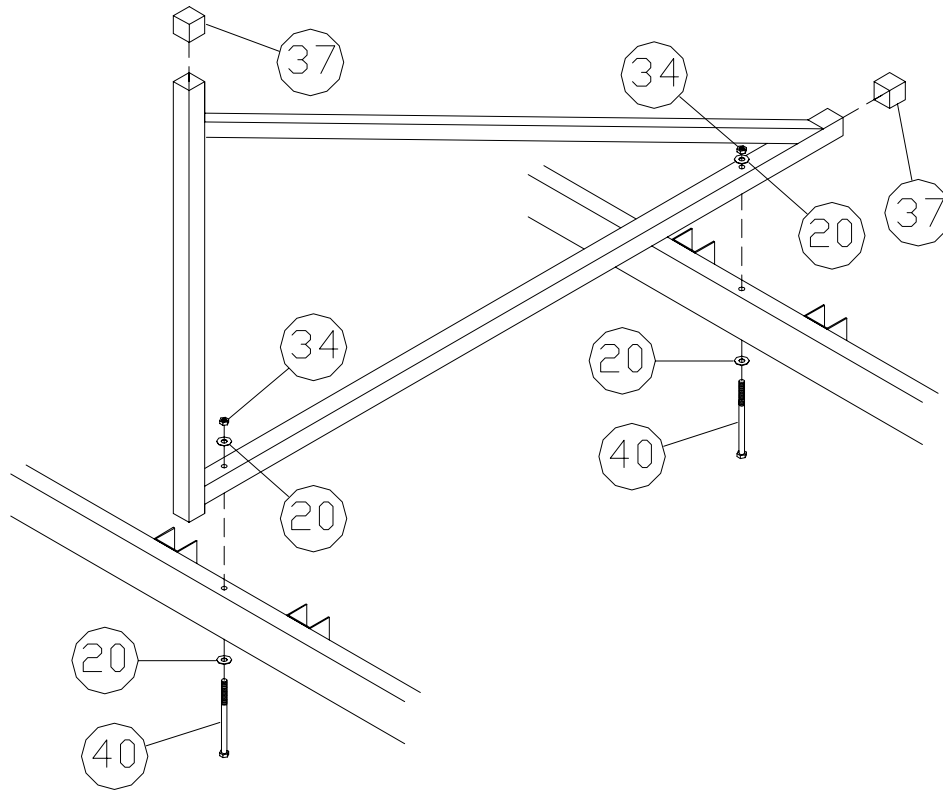

STEP 3. Locate the four H shaped lifting arms (REF. # 5). Slide a Brass pivot bushing (REF. # 18) into each pivot cap on the ends of the lifting arms. Place the lifting arm into the channels of the bottom cross tubes and fasten into place using 1/2" X 3" clevis pins and 1/2" washers (REF. # 19 & 20). Secure with cotter pins. (REF. # 21).

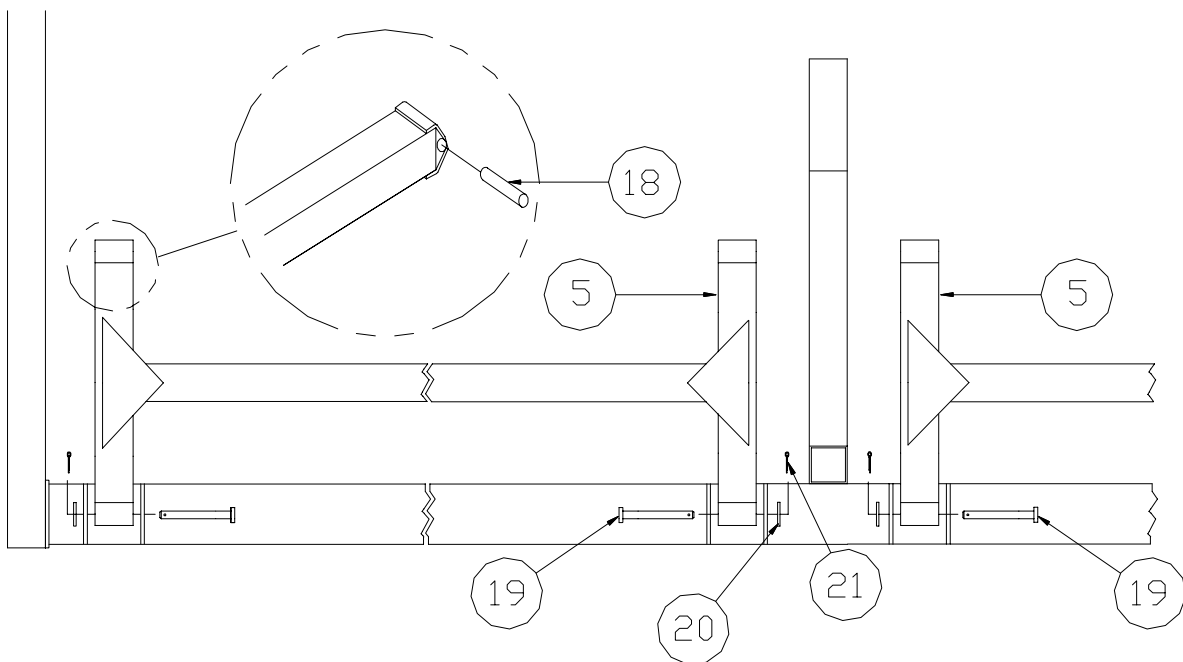

STEP 4. Find the lifts top bed members (rec. frame 52 3/4" X 72 1/4") (**REF. #6**). Set the bed member pivot channels into the ends of the lifting arms. The pivot channels on the outside of the bed are toward the front of the lift. Locate the two front pulley brackets, 1/2" X 6" clevis pins, and 1/2" washers (**REF. # 13, 22 & 20**). On the front corner of the bed, place a pulley bracket with the pulley sheave toward the outside, in between the corner angle and the pivot channel. From the corner angle side, slide a 1/2" X 6 1/2" clevis pin through the angle and the pulley bracket into two 1/2" washers and through the lifting arm and pivot channel. Place another 1/2" washer over the clevis pin and secure with cotter pin. (See illustration after **STEP 5**)

STEP 5. Fasten the rear lifting arms to the back pivot channels of the member with 1/2" X 3" clevis pins, 1/2" washers, and cotter pins (**REF. # 19, 20 & 21**).

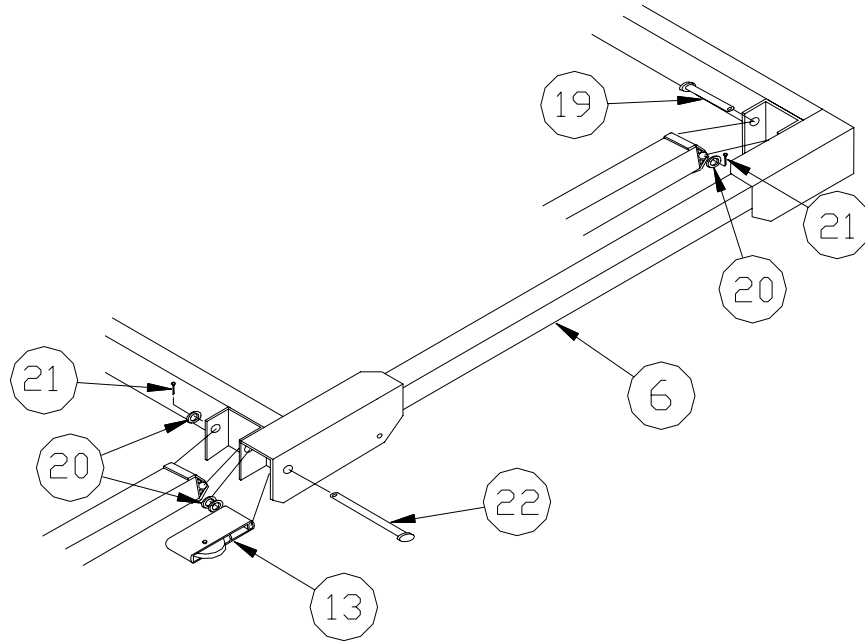

STEP 6. Find the winches (**REF. # 8**), the winch is simply turned over to go either left or right. If installing a canopy, place the canopy mounting bracket into the upright tube (see canopy instructions). Bolt the winch to the inside of the front upright using 3/8" fender washers (**REF. # 25**) on the tube side and standard 3/8" washers (**REF. # 28**) on the winch side. Use 3/8"X 3" bolts (**REF. #29**). Find the lift cable (**REF. # 14**), thread the plain end of the cable through the hole in the side of the winch drum.

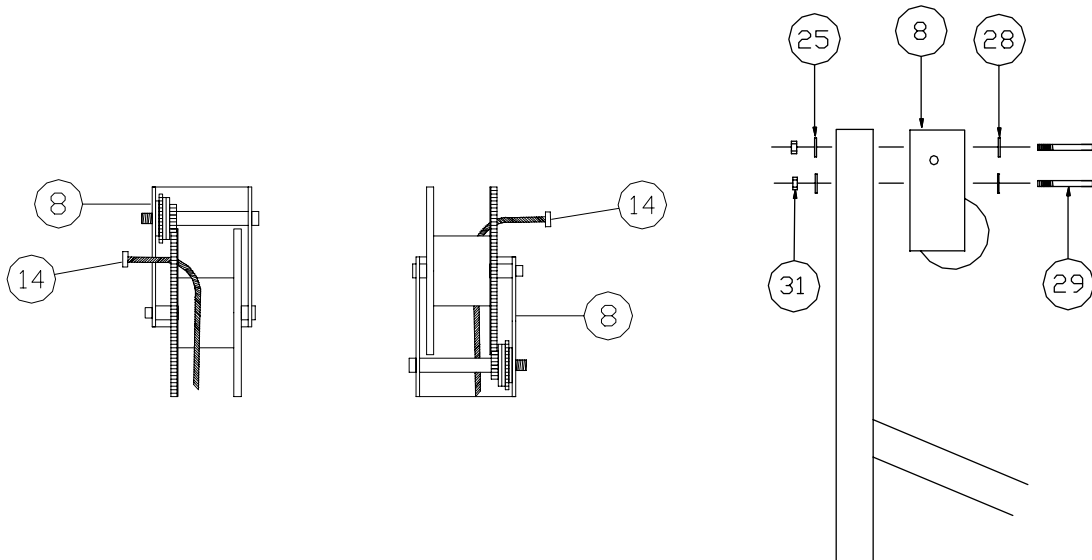

STEP 7. Locate two round U-bolts (REF. # 23) and the two pulley and chain assemblies (REF. # 24). Place the U-bolt through the chain link and into the two holes directly below the winch and above the diagonal tube of each side member. Secure the U-bolts with 3/8" fender washers and nylock nuts (REF. # 25 & 26). Only finger tighten nuts at this time. Place the other U-bolt through the two cable thimbles (REF. # 27) and secure to center side member in the same manner. Pass the cable through the pulley sheave in the pulley bracket. Then run the cable up to and through the pulley on the front bed cross tube across to and through the other pulley. Bring the cable back up to the other U-bolt in the center side member and around the cable thimble and secure with cable clamp (REF. # 30). Install lift wheel (REF. # 9) on winch and secure with winch hardware. Repeat the cable threading procedure on the other side of the lift. Turning lift wheel clockwise, raise the bed of the lift 3/4 of the way up. Tighten the nylock nuts on the u-bolts at this time and install the plastic caps (REF. # 39) onto the threads of the u-bolts.

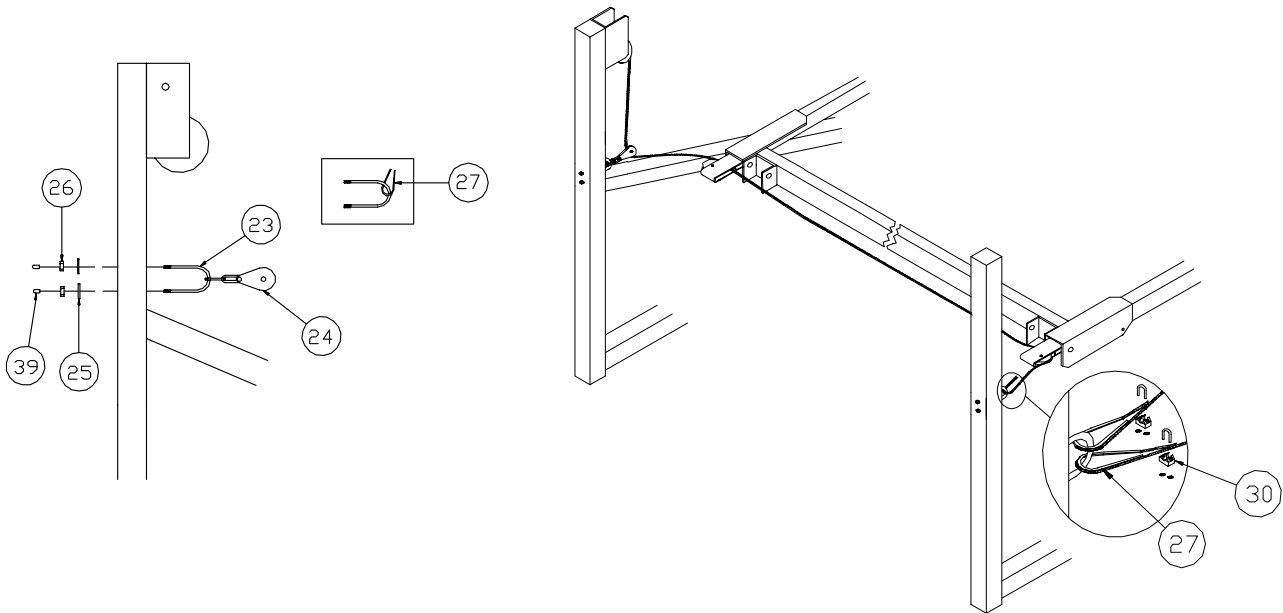

STEP 8. Find the four front angle braces (REF. # 7) (description 1 1/4" X 1 1/4" X 26 3/4" angle with slotted holes on each end) On the outside side members bolt the one end to the inside face of the front upright tube with a 3/8" X 3" bolt, washer, and nut. (REF. # 29, 28 & 31) Bolt the other end to the side of the bottom cross tube using the same size bolt, washers, and nuts. On the center side member, bolt two angle braces to the inside face of the front upright tube with a 3/8" X 3 1/2" bolt, washer, and nut (REF. # 38, 28 & 31). Bolt the other ends of the angle braces to the bottom cross tube with 3/8" X 3" bolts, washers, and nuts (REF. # 29, 28 & 31). Tighten up bottom cross member nut first so that the slot is about in the middle of the bolt. Check front upright for straightness. Adjust upright if necessary and tighten bolt in upright tube.

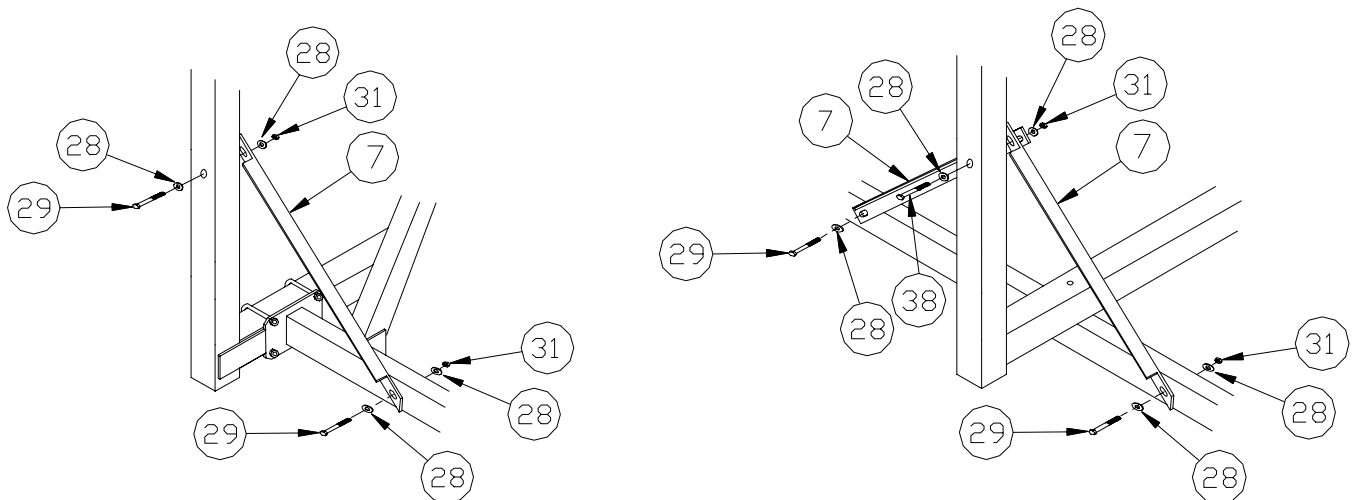

STEP 9. Take two stop chains (**REF. # 32**) and bolt the one end to the bottom side of the diagonal brace tube of the outside side members using a 3/8" X 3" bolts. Place the chain link between two 3/8" washers and secure with a 3/8" nylock nuts (**REF. # 28 & 26**). Tighten enough so that the nylock nut is fully engaged with the thread of the bolt, yet chain should still turn freely. Fasten the other end of the chain to the inside of the corner of the angle of the top bed cross tube by placing the chain link between two 3/8" washers and securing with a 3/8" X 1 1/2" bolt and nylock nut (**REF. # 28, 33, & 26**). Again tighten the nylock nut so that the nylon of the nut is engaged with the thread of the bolt, but the chain can still turn freely. On the center side bolt the remaining two chains to the bottom side of the diagonal brace tube by placing a 3/8" X 3 1/2" bolt through the hole in the diagonal brace, then placing a washer on the bolt, then a chain, a washer, the other chain, another washer and a 3/8" nylock nut. Secure the other ends of the chains to the top bed in the same manner as described before.

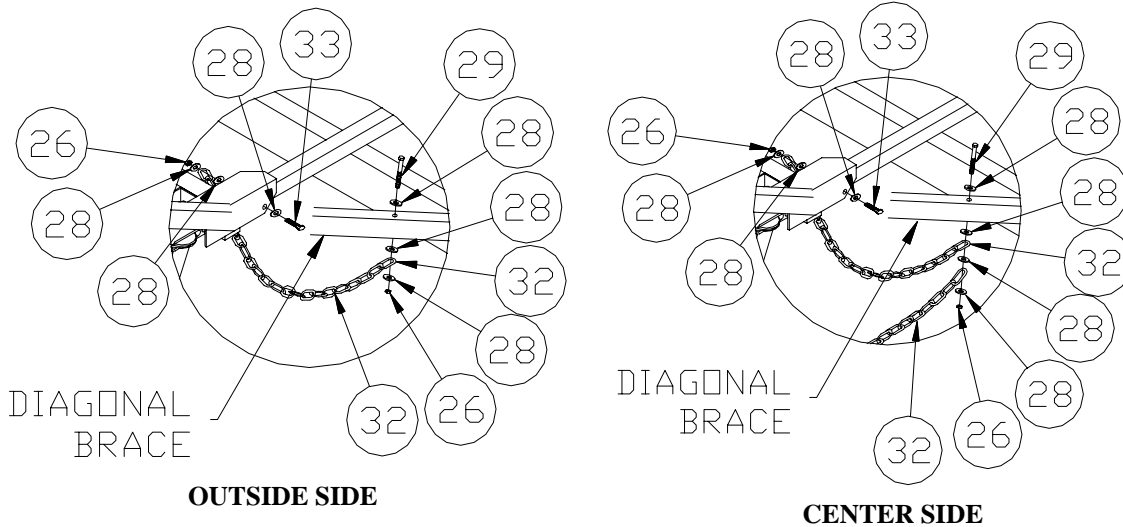

STEP 10. Find the four bunk mounting angles (1 3/4" X 1 3/4" X 9" angle with multiple holes), (**REF. # 10**). The angles can be adjusted for height by putting the u-bolt through the bottom hole or the second to the bottom hole. Bolt the angles to the bed using 3/8" X 3" X 3 1/6" U Bolts, washers & nuts (**REF. # 35, 28 & 31**). The angles must be turned as shown in the diagram. Leave loose at this time.

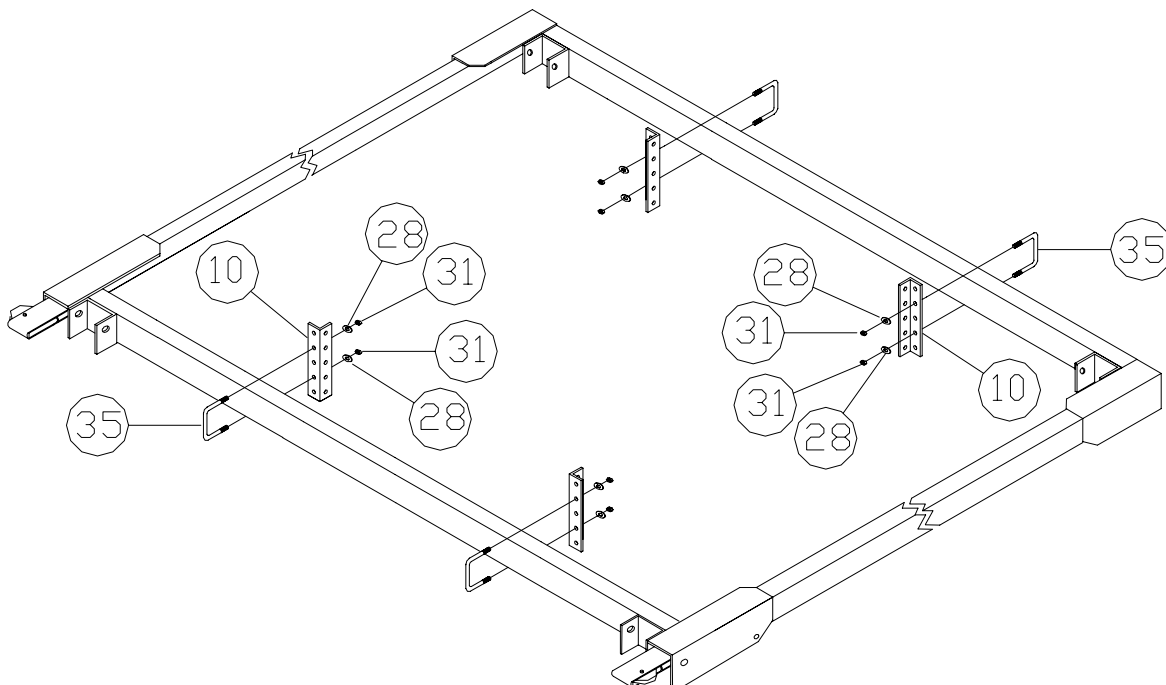

STEP 11A. Set the bunk assembly (**REF. # 12**) on the bunk mounting angles. With the tabs on the bunk assembly to the outside of the angles. Bolt in place with $3/8'' \times 1\ 1/2''$ bolts, washers, and locknuts (**REF. # 33, 28 & 26**). Tip bunks inward slightly and tighten bolts so that the bunks will not turn freely but can pivot when weight is applied. Adjust bunks to the desired width then tighten the nuts on the U-bolts. After your personal watercraft has been on the bunks and has been raised and lowered, the position of the bunks will be established. Re-tighten the bunk bolts at this time so the bunks cannot turn.

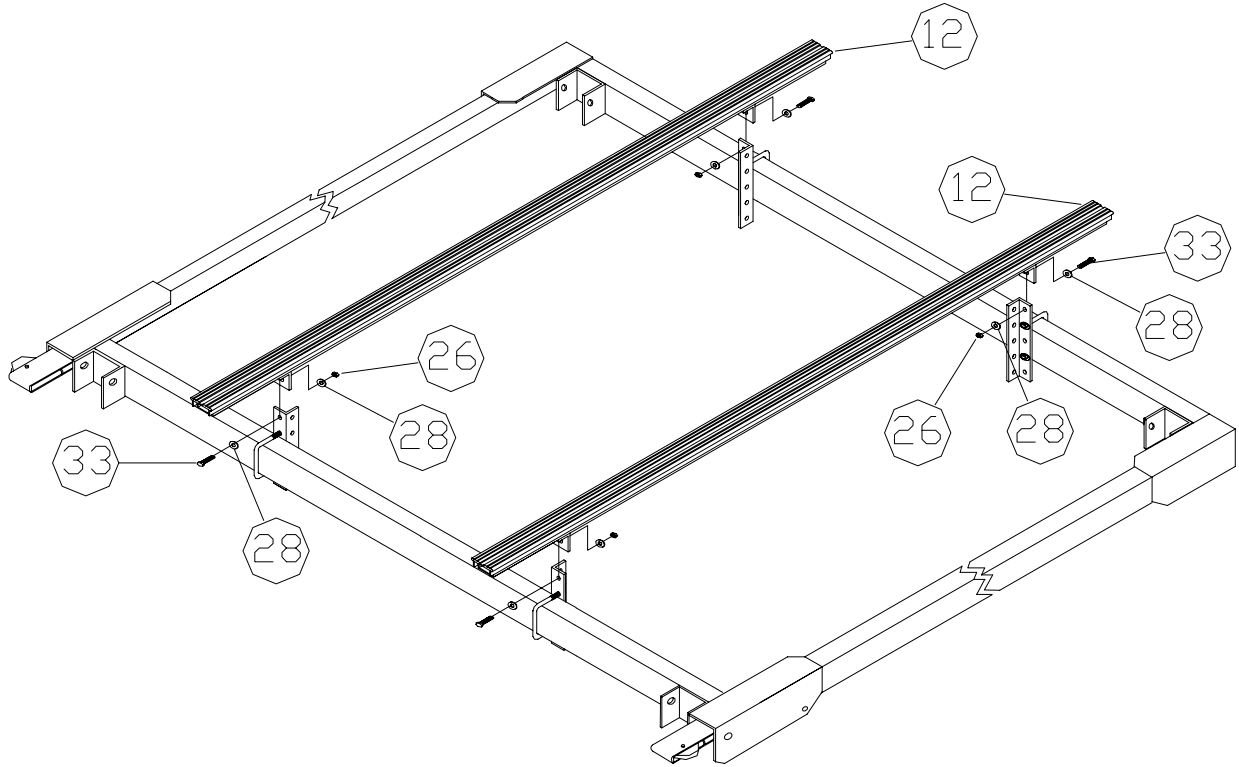

PARTS LIST

65A 1155 DOUBLE PERSONAL WATERCRAFT LIFT

REF. #	PART #	DESCRIPTION	QTY
1	62H	LEVELING LEG	4
2	61E	SIDE MEMBER RIGHT	1
3	62E	SIDE MEMBER LEFT	1
4	63E	BOTTOM CROSS TUBE 1155	2
5	59E	LIFTING ARMS 1155	4
6	64E	TOP BED MEMBER 1155	2
7	70120	DIAGONAL FRONT BRACE	4
8	3180	WINCH DLB1200A	2
9	23E	WINCH WHEEL SMALL	2
10	60300	BUNK MOUNTING ANGLE 9"	8
11	60E	CENTER SIDE MEMBER 1155	1
12	16F	BUNK ALUM / VINYL 83"	4
13	99F	PULLEY BRKT 3" X 2.375"	4
14	3108	CABLE 1/4" X 21'	2
15	4504	SPINNER KNOB	2
16	5046	U-BOLT SQ 2"	8
17	5156	FLANGE NUT 3/8"	16
18	3313	BRASS BUSHING 5/8" X 2"	16
19	5097	CLEVIS PIN 1/2" X 3"	12
20	5071	WASHER 1/2"	28
21	5025	COTTER PIN 1/8" X 1 1/4"	16
22	5190	CLEVIS PIN 1/2" X 6"	4
23	5034	U-BOLT ROUND	3
24	E75	PULLEY 2 1/2" 2 LINK	2
25	5067	WASHER FENDER 3/8"	10
26	5038	NUT NYLOCK 3/8"	21
27	5044	CABLE THIMBLE 1/4"	2
28	5070	WASHER 3/8"	72
29	5084	BOLT 3/8" X 3"	12
30	5004	CABLE CLAMP 1/4"	2
31	5056	NUT 3/8" STANDARD	27
32	3093	CHAIN STOP 3/16" X 27 LINK	4
33	5155	BOLT 3/8" X 1 1/2"	12
34	5058	NUT 1/2"	2
35	5103	U-BOLT SQ 3/8" X 3" X 3 1/16"	8
36	5174	SET SCREW 1/2" X 1"	4
37	3821	CAP 2" SQUARE GRAY	4
38	5085	BOLT 3/8" X 3 1/2"	2
39	3828	CAP .343" X 1/2" PVC MOLDED CAP	6
40	5130	BOLT 1/2" X 8"	2

