

PORTA-DOCK, INC**T65 WINCH KIT FOR STEEL WHEEL DOCK**

Thank you for purchasing our product!

Please read these instructions and follow them step by step.

STEP 1. Bolt winches (**REF. # 4**) with 3/8" x 1" bolts and nuts (**REF. # 9 & 6**) with winch handle to the outside. Attach winch handle (**REF. # 3**) with winch nuts (**REF. # 10**). Insert pulleys (**REF. # 1**) into the top of vertical lift member. Starting winch cable (**REF. # 2**) from the outside of the winch, pass cable through the hole on the side of the drum opposite of gears. Run cable over top of pulley in vertical lift member, down to the loop welded on the side of the pocket opposite winch. Fasten with cable clamp (**REF. # 5**). Operate winches until the slack is out of the cables. Do not over tighten cable when the setscrews are still tight.

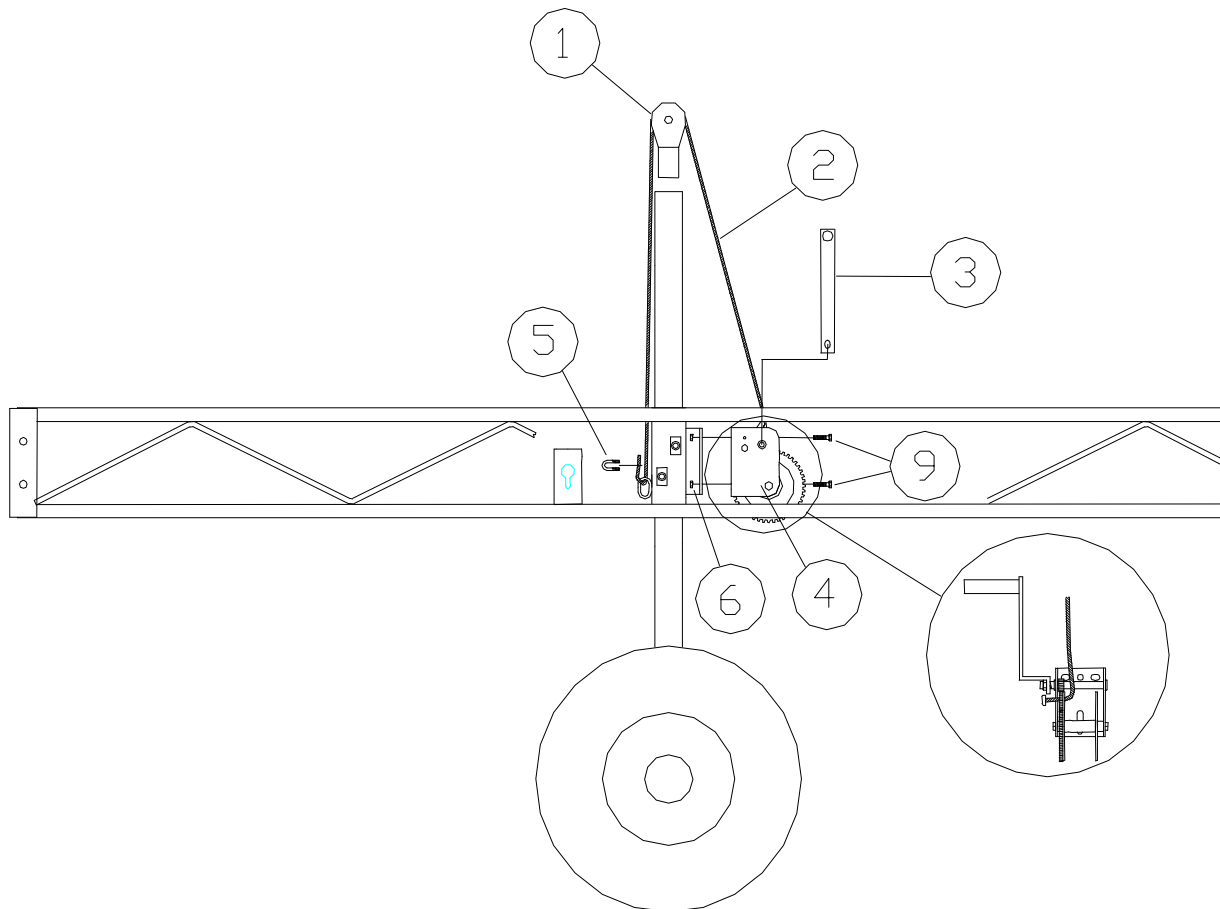

STEP 2. Bolt chains (**REF. # 7**) to the inside holes on the axle using a 3/8" x 3" bolt and nut. Run the other end of the chain up to the opposite side of the dock through the keyhole bracket located next to the vertical lift member pocket.

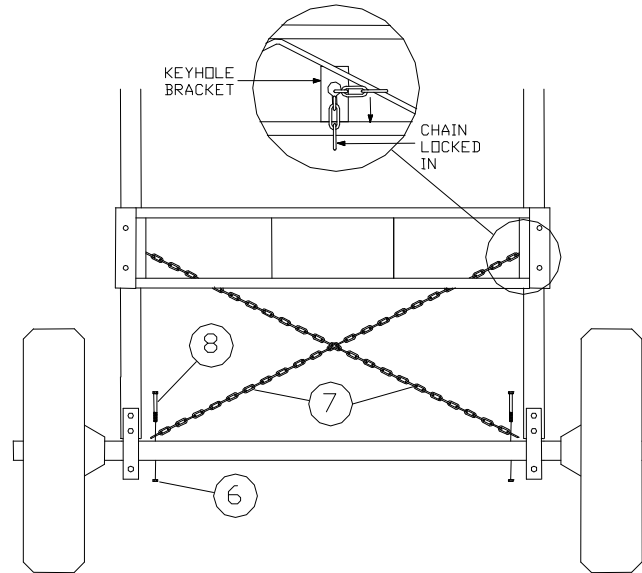

Before moving your dock into the water, make sure that the chains are not wrapped around the axle, and then pull the slack out of the chains by hooking them into the keyhole bracket. Roll your dock into position, and loosen the set screws on the VLM pocket. Adjust the dock to the desired height making sure that there is enough slack in the chains to accommodate the height you will be adjusting to. Once the desired height is reached, pull both the chains tight and then lower one side of the dock so the next link can be hooked into the keyhole slot and raise the dock back up to complete the tightening of the chain. Repeat on the other side. When finished with this, there should be no visible slack left in the chains, and they should be tight enough that you can't move them. Tighten the set screws in the VLM pocket.

The cross chains are to help control the side-to-side stability of the end of the dock and need to be tight. Once set they only need to be adjusted if the height of the dock is changed.

WARNING: before raising the dock it is necessary to loosen both of the chains and the set screws, or serious damage to the dock may occur. When tightening the set screws, they should be tightened until they are snug against inside leg, and then tightened 1 1/2 to 2 turns more. Check the set screws after a couple of uses and retighten if necessary.

When moving dock into and from lake, lower dock to lowest level possible.

| REF. # | PART # | DESCRIPTION | QTY |
|--------|--------|-------------------|-----|
| 1 | T69 | STEEL DOCK PULLEY | 2 |
| 2 | 3050 | CABLE 3/16" X 15' | 2 |
| 3 | 3008 | WINCH HANDLE | 2 |
| 4 | 3009 | WINCH DL900 | 2 |
| 5 | 5003 | 3/16" CABLE CLAMP | 2 |
| 6 | 5056 | 3/8" NUT | 6 |
| 7 | 3072 | CHAIN 3/16" X 9' | 2 |
| 8 | 5084 | 3/8" X 3" BOLT | 2 |
| 9 | 5081 | 3/8" X 1" BOLT | 4 |
| 10 | 5066 | WINCH NUT HDW BAG | 2 |



Wheel dock height adjustment instructions

Before moving your dock into the water, make sure that the chains are not wrapped around the axle, and then pull the slack out of the chains by hooking them into the keyhole bracket. Roll your dock into position, and loosen the set screws on the VLM pocket. Adjust the dock to the desired height making sure that there is enough slack in the chains to accommodate the height you will be adjusting to. Once the desired height is reached, pull both the chains tight and then lower one side of the dock so the next link can be hooked into the keyhole slot and raise the dock back up to complete the tightening of the chain. Repeat on the other side. When finished with this, there should be no visible slack left in the chains, and they should be tight enough that you can't move them. Tighten the set screws in the VLM pocket.

The cross chains are to help control the side-to-side stability of the end of the dock and need to be tight. Once set they only need to be adjusted if the height of the dock is changed. **WARNING: before raising the dock it is necessary to loosen both of the chains and the set screws, or serious damage to the dock may occur.** When tightening the set screws, they should be tightened until they are snug against inside leg, and then tightened 1 1/2 to 2 turns more. Check the set screws after a couple of uses and retighten if necessary.

When moving dock into and from lake, lower dock to lowest level possible.