

**PORTA-DOCK, INC.****C162 16" MULTI-DOCK POCKET W/ SCREW LEG ASSEMBLY****C164 24" MULTI-DOCK POCKET W/ SCREW LEG ASSEMBLY**

**Thank you for purchasing our product!**

**\*Please read these instructions and follow them step by step.**

**STEP 1.** Slide the post (REF. NO. 3) into the pocket assembly making sure that the tab on the post is facing the side of the pocket that has the set screw holes in it. Temporarily secure the leg in place with a 1/2" X 1" set screw (REF. NO. 12). Install another 1/2" X 1" set screw (REF. NO. 12) into the tapped hole in the outer pocket, leave loose at this time.

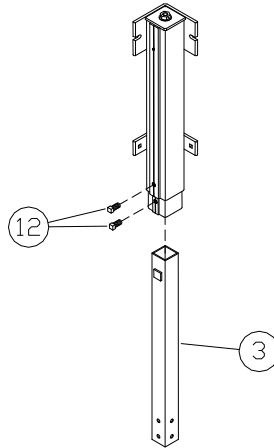

**NOTE:** The diagrams are shown right side up, but it may be easier to assemble the dock upside down.

**STEP 2.** If installing swivel pads (REF. NO. 4) bolt them to the legs with 3/8" X 3 Bolts, washers, and locknuts (REF. NO. 11, 10, & 8). If installing a wheel kit refer to those instructions and install at this time. Bolt the pockets into the frame by sliding 3/8" X 1" carriage bolts (REF. NO. 13) into the access holes in the frame at the corners where the pockets will go. Hold the pocket in position and slide the carriage bolts into the slots in the angle and secure with 3/8" washers and nuts (REF. NO. 10 & 9). Note: the swivel pads may be turned the other way.

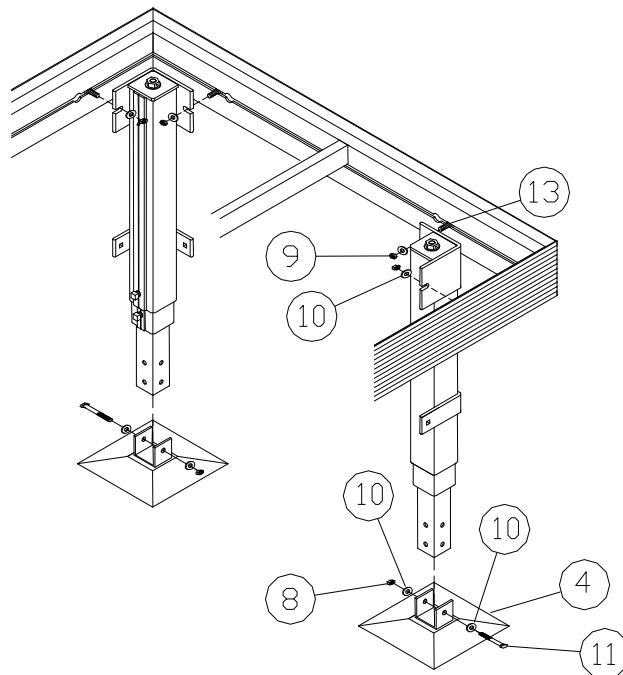

**STEP 3.** Bolt the braces (REF. NO. 5) to the bottom angles of the pocket with 3/8” X 1” carriage bolts, washers, and nuts (REF. NO. 13, 10, & 9) Bolt the other ends of the braces to the frame by sliding 3/8” X 1” carriage bolts (REF. NO. 13) into the access holes in the frame at the corners where the braces will go and securing with 3/8” washers and nuts (REF. NO. 11 & 10).

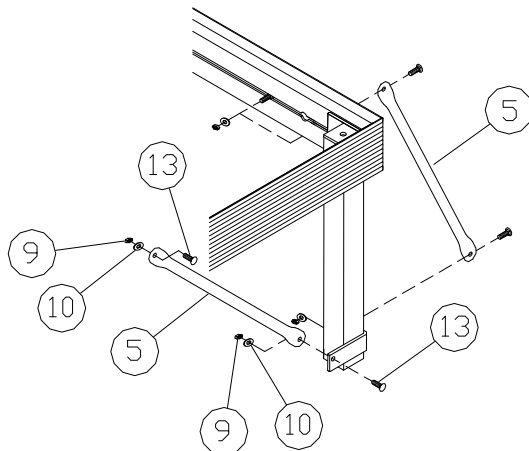

### USE AND MAINTENANCE

The set screws **MUST** be loosened before adjusting the dock. Adjust the height of the dock by tuning the nut with a 7/8” socket and ratchet or a 7/8” socket in a cordless drill. Clockwise will lower the dock, and counter clockwise will raise the dock. **Do not use an impact wrench, as the hammering effect will cause extra wear on the drive shaft.** When adjusting the posts, loosen the set screw only enough so the leg will slide freely, this will allow the retaining tab to keep the post from sliding all the way out. Each fall when the dock is removed, adjust the leg so it is all the way up in the pocket and grease with a non-petroleum based lubricant. Adjust the leg all the way up and then all the way down. This will help distribute the lubricant onto the entire shaft.

### C162 16” MULTI-DOCK POCKET W/ SCREW LEG ASSEMBLY C164 24” MULTI-DOCK POCKET W/ SCREW LEG ASSEMBLY

REF. #	PART NO.	DESCRIPTION	QTY
1	C152	16” OUTER POCKET	2
	C154	24” OUTER POCKET	2
2	22DK	17” INNER POCKET	2
	24DK	23” INNER POCKET	2
3		2” X 2” MULTI DOCK POST	2
4	59F	SWIVEL PAD	2
5	60158	19” BRACE	4
6	5203	1/2” STAINLESS STEEL WASHER	6
7	5198	1/2” BRASS WASHER	2
8	5038	3/8” NYLOCK NUT	2
9	5056	3/8” NUT	12
10	5070	3/8” WASHER	16
11	5084	3/8 X 3 BOLT	2
12	5170	1/2" X 1" SET SCREW	2
13	5193	3/8 X 1 CARRIAGE BOLT	12
14	5011	GREASE ZERK	2
15	5232	1/2" ACME NUT TAPPED	2
16	5129	ALLEN HEAD SET SCREW 8-32 X 5/8”	2

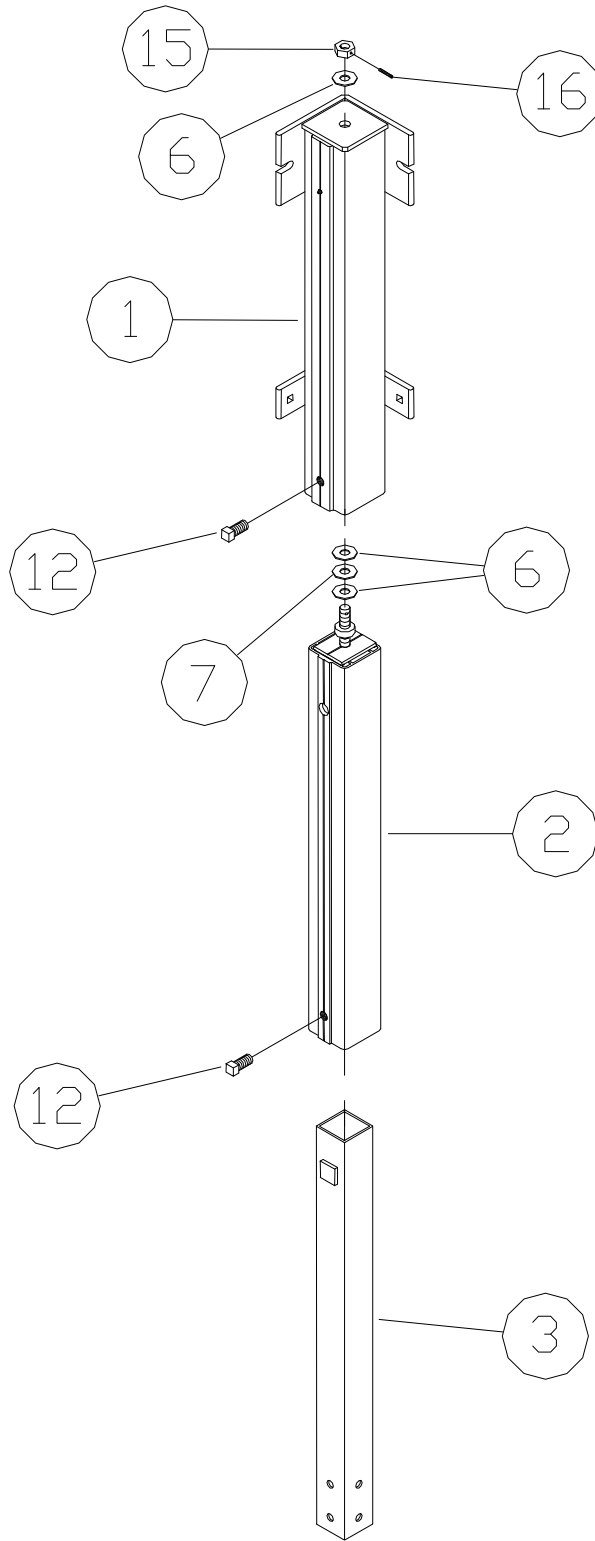

Porta-Dock, Inc.