

PORTA-DOCK, INC.

MULTI-DOCK CORNERS

APM60(B) RIGHT CORNER FOR APM, APM65(B) LEFT CORNER FOR APM
AWM60 RIGHT CORNER FOR AWM, AWM65 LEFT CORNER FOR AWM

Thank you for purchasing our product.
Please read these instructions and follow them step by step.

NOTE: For APM corner sections only, run foam tape on the top side of the frame.

STEP 1. Bolt a dock connecting angle to the side of the walkway and two dock connecting angles to the end of the L-section approximately 7" from the corners of the dock frames as shown, by sliding a 3/8" X 1" carriage bolt (REF. NO. 9) into the bottom access holes in the frame where the connection will be and secure the angle with 3/8" washers and nuts (REF. NO. 11 & 10). Set the corner section on these angles. Making sure the corner is even with the side of the L-section, slide a 3/8" X 1" carriage bolt (REF. NO. 9) into the access hole in the corner frame, slide the dock connecting flat (REF. NO. 4) into the slot in the dock connecting angle and secure with a 3/8" washer and nut (REF. NO. 11 & 10). After the flat is in the slot place a pin (REF. NO. 12) through the hole. **NOTE:** If using a bench on the corner, connect the inside of the corner to main walkway with the center support flat (REF. NO. 13) by sliding a 3/8" X 1" carriage bolt (REF. NO. 9) into the access holes in the frame where the connection will be and secure the flat with 3/8" washers and nuts (REF. NO. 11 & 10).

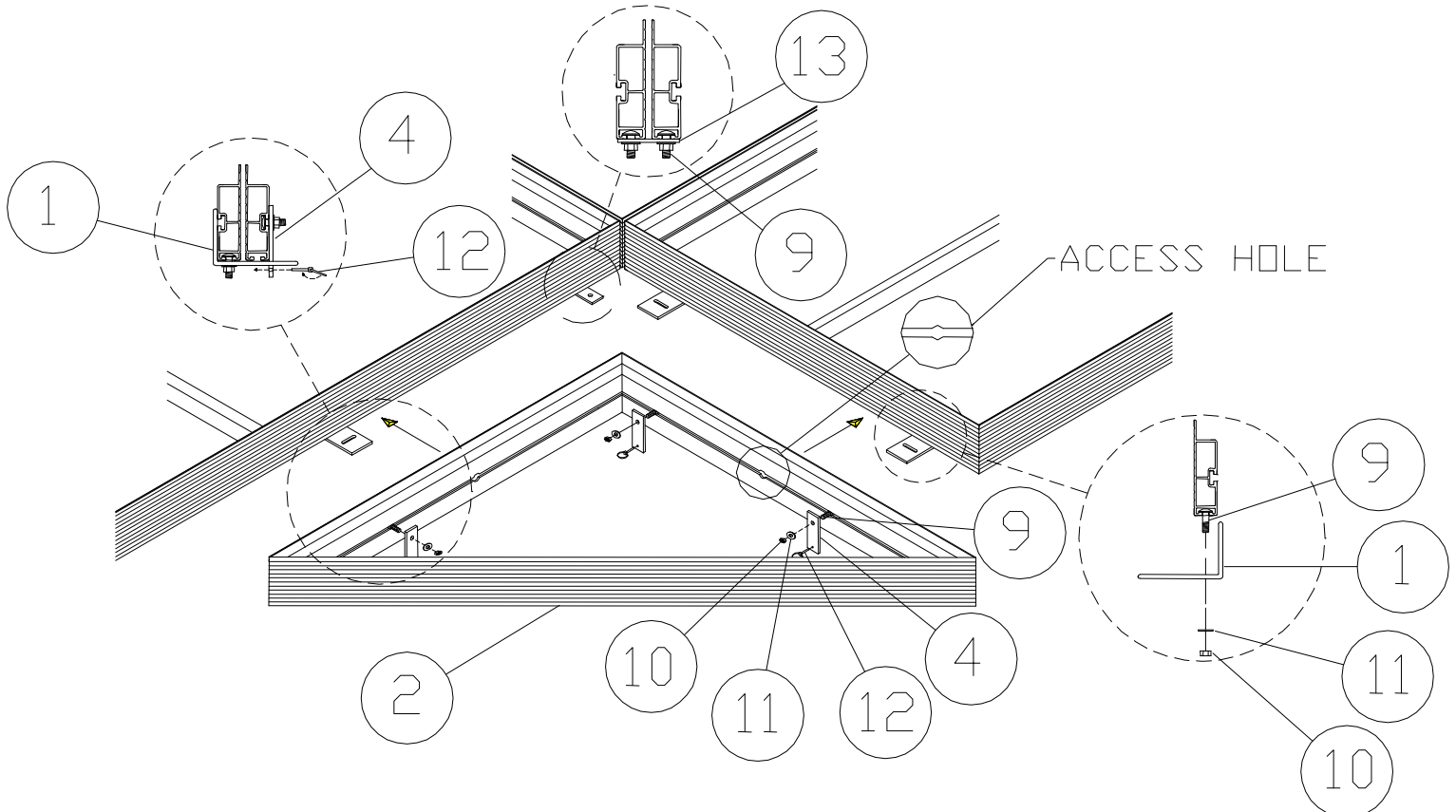

STEP 3. Place the panel into frame. On the cedar panel, place the small corner board (Ref. No. 3) into the corner of the frame. Fasten into place by placing the aluminum flat (Ref. No. 7) underneath the framework across both bottom tubes. Run a 5/16" X 6 1/2" carriage bolt (Ref. No. 5) through the board into the aluminum flat and tighten in place with 5/16" nut (Ref. No. 6).

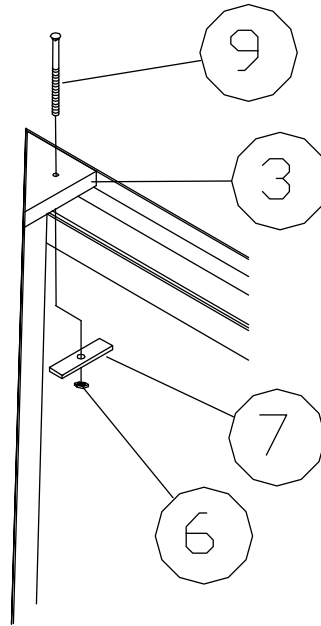

REF. #	Part #	Description	APM	AWM
1	60153	DOCK CONNECTING ANGLE	3	3
2	M80	MULTI-DOCK CORNER FRAME	1	1
3	30501	CORNER BOARD	-	1
4	60145	DOCK CONNECTING FLAT	3	3
5	5211	5/16" X 6 1/2" CARRIAGE BOLT	-	1
6	5054	5/16" NUT	-	1
7	30400	ALUMINUM CORNER FLAT	-	1
8	4108	FOAM TAPE 16'	1	-
9	5193	3/8" X 1" CARRIAGE BOLT	3	3
10	5056	3/8" NUT	3	3
11	5070	3/8" WASHER	3	3
12	5239	LYNCH PIN 3/16" X 9/16"	3	3
13	60190	CENTER SUPPORT FLAT	1	1
	B43	4' ALUMINUM CORNER PANEL RIGHT	1	-
	B84	4' ALUMINUM CORNER PANEL LEFT	1	-
	B83	4' CEDAR PANEL RIGHT CORNER	-	1
	B82	4' CEDAR PANEL LEFT CORNER	-	1