

PORTA-DOCK, INC.

AP82 APD DS 6' X 12' PLATFORM **AW82 CPD DS 6' X 12' PLATFORM**

Thank you for purchasing our product!

***Please read these instructions and follow them step by step. ***

If you are assembling a 6 X 12 platform dock please use these instructions in place of the step 1 instruction in the main packet.

Bolt the center dock section with no pockets between the other two sections as shown with 1/2" x 1 1/4" bolts, washers and nuts (**REF. # 20, 36 & 3**). **Note: the docks are assembled so the pockets that are welded into the frames are to the outside of the assembly.** Bolt dock connector brackets (**REF. # 9**) to the lower side holes of the angle with 1/2" x 1 1/4" bolts, washers and nuts. Do not install a dock connector bracket where you will connect an add on section later. Next slide two support posts (**REF. # 24**) into the two outside corner pockets of the section with the three pockets. Temporarily secure the legs with 1/2" X 3/4" set screws (**REF. # 6**). Bolt the winches on as described in step 1A.

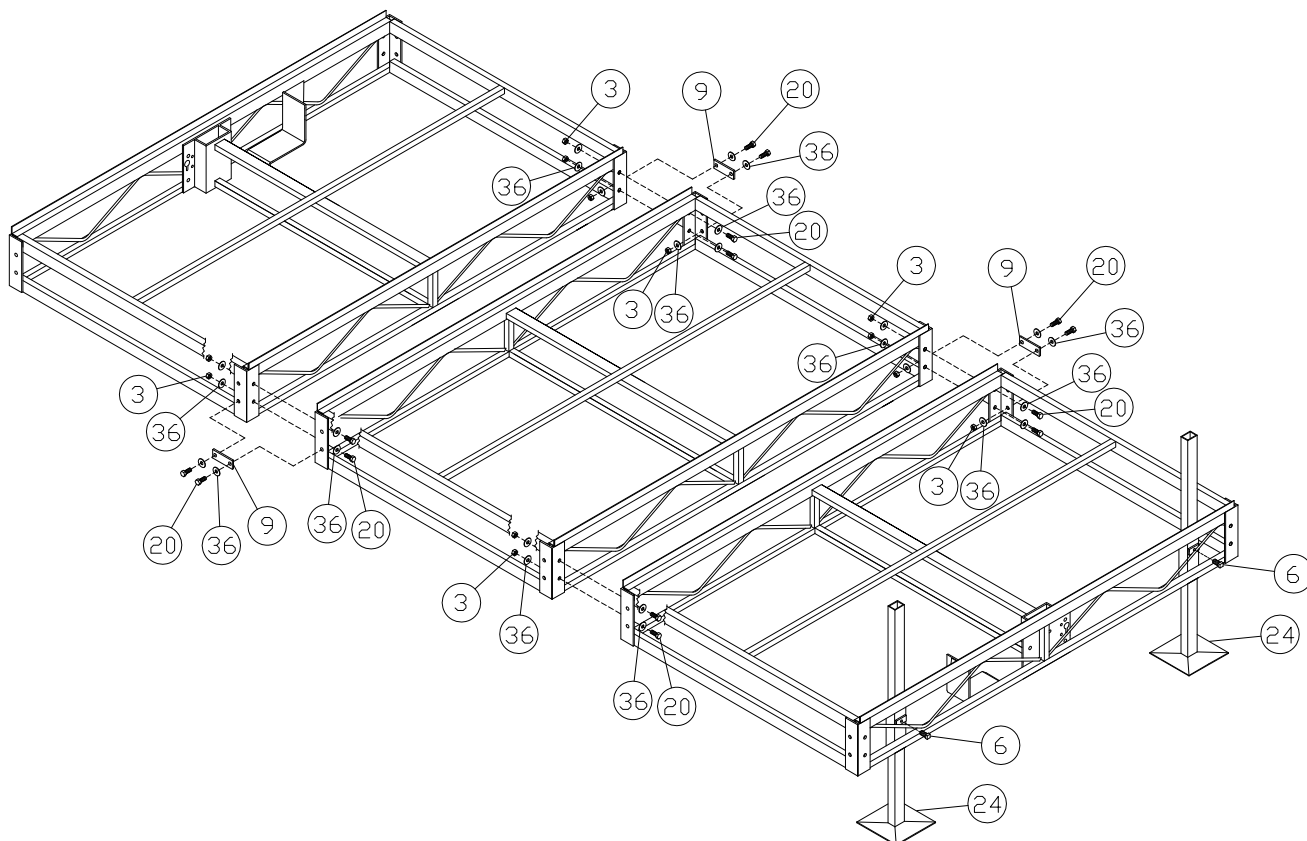

FRAMES

REF. #	PART NO.	DESCRIPTION	APD	CPD	AA
	MS01	4' X 6'5" L PLATFORM SECT.	1	1	-
	MS02	4' X 6'5" CENTER PLATFORM SECT.	1	1	-
	MS03	4' X 6'5" L PLATFORM SECT. 2 PKT.	1	1	-

PANELS

REF. #	PART NO.	DESCRIPTION	APD	CPD	AA
	B115 (B)	4' X 3' ALUM PL STRAIGHT	2	-	-
	B111 (B)	4' X 3' ALUM PL L12 CUTOUT	1	-	-
	B112 (B)	4' X 3' ALUM PL L RIGHT CUTOUT	1	-	-
	B113 (B)	4' X 3' ALUM PL L12 RIGHT CUTOUT	1	-	-
	B114 (B)	4' X 3' ALUM PL L12 LEFT CUTOUT	1	-	-
	B53	4' X 4' CEDAR PL STRAIGHT	-	1	-
	BB47	4' X 4' CEDAR PL VLM LT CUTOUT	-	1	-
	BB48	4' X 4' CEDAR PL VLM CUTOUT	-	1	-
	BB49	2.5' X 4' CEDAR PL ADD RT CUTOUT	-	1	-
	BB8	2.5' X 4' STRAIGHT	-	2	-