

**PORTA-DOCK, INC.**  
**AD05- DS 4'X 16'L8-AA / AP05- DS 4'X 16'L8-APD**  
**AW05- DS 4'X 16'L8-CPD ALUMINUM PORTA-DOCK**

**\*For Beige Decking Add the Letter B to the Model\***

**Thank you for purchasing our product!**

**\*Please read these instructions and follow them step by step.**

**Step 1.** Decide if you want your L dock to the right or left. Lay the 8' section next to that side of the 16' wheel end section. Bolt the 8' L section to the side of the 16' wheel end section using 1/2" x 1 1/4" bolts, washers and nuts. (REF. # 20, 35 & 3) Bolt dock connector brackets (REF. # 9) to the lower side holes of the angle with 1/2" x 1 1/4" bolts and nuts. Bolt the center of the 8' section to the inside pocket of the 16' section using 1/2 x 2 1/2" bolts and nuts. (REF. # 15 & 3)

**NOTE:** If assembling an AA dock, the center section will have to be bolted together when the dock is raised off the ground. After **Step 5.** Block the dock up about 2' behind winch plates on both the 8' and 16' sections. Then bolt winch (REF. # 11) with 3/8" x 1" bolts and nuts (REF. # 18 & 2) to the outside winch plate of the 16' section with the winch handle stub to the outside. Bolt winch on in the same manner to the outside of the 8' section.

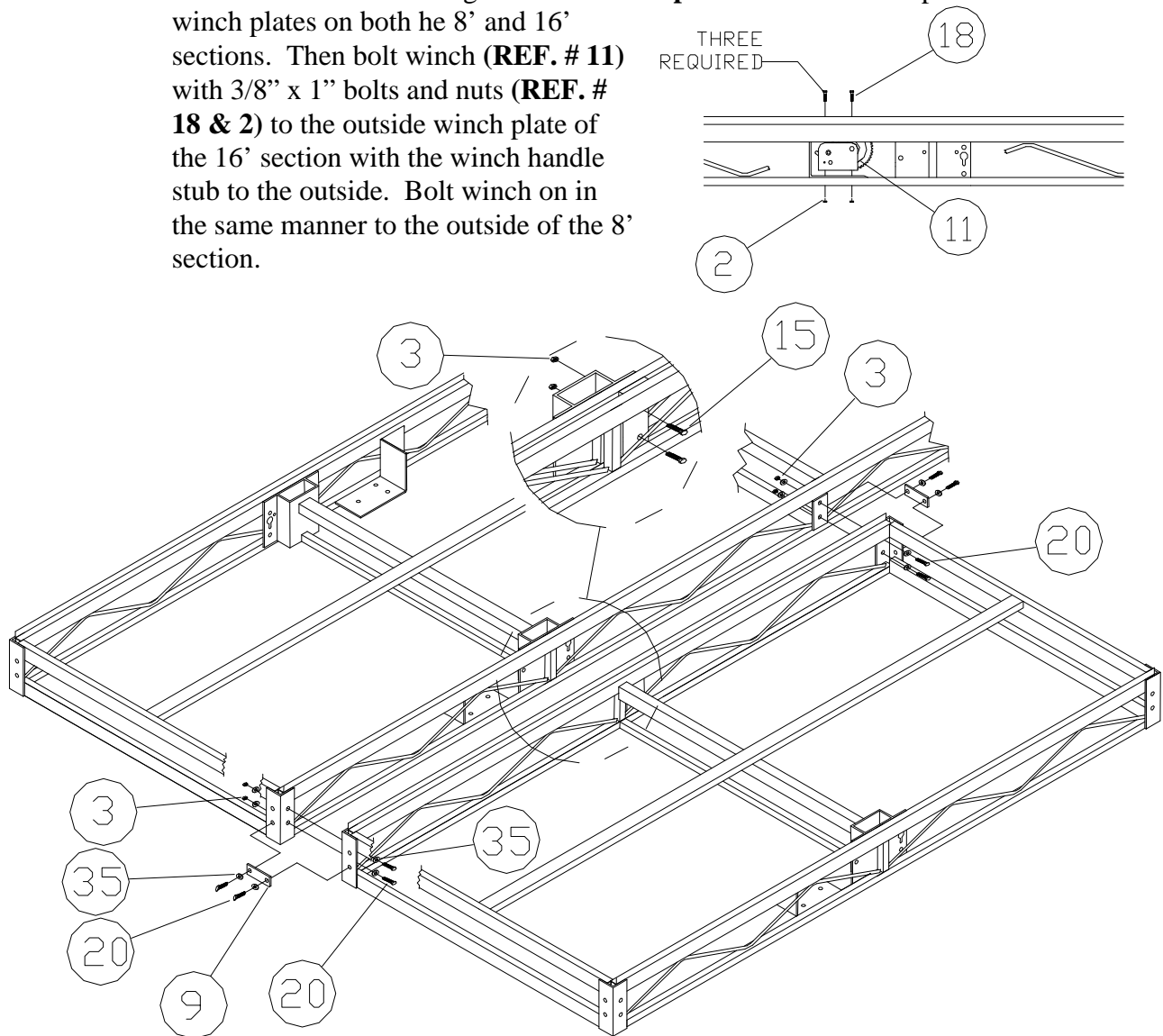

**Step 2.** Apply the four nylon wear strips (**REF. # 32**) to the inside narrow ends of the pockets. Pockets should be clean and dry and above 50 degrees. Slide a VLM cover plate (**REF. # 38**) onto each vertical lift member. Attach dock pulleys (**REF. # 14**) with 1/2" x 2 1/2" bolts and nuts (**REF. # 15 & 3**) to top of vertical lift members (**REF. # 7**). Insert vertical lift members into pockets on each side of dock. Screw the set screw (**REF. # 6**) into the face of the pockets. Leave all sets screws loose at this time.

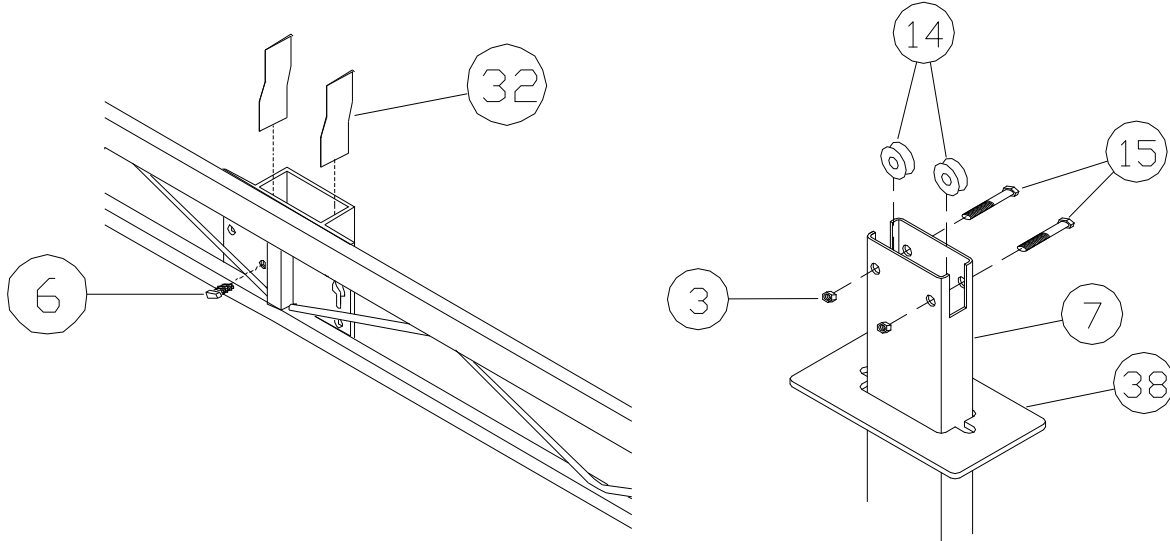

**Step 3.** Attach chains (**REF. # 16**) to inside holes of axle (**REF. # 10**) with 3/8" x 3" bolts and nuts (**REF. # 19 & 2**). Slide on the 3" washers (**REF. # 8**) then the dock wheels (**REF. # 4**) with the hub protruding toward the outside onto the axle, up to the washer and chains. Slide on the lift member brackets (**REF. # 13**) and place the 1/4" X 2 1/2" pin (**REF. # 1**) in the holes in the ends of the axle. Roll axle under dock, keeping axle centered with dock. Bolt lift member bracket (**REF. # 13**) to vertical lift members (**REF. # 7**) with 3/8" X 3" bolts and nuts (**REF. # 19 & 2**).

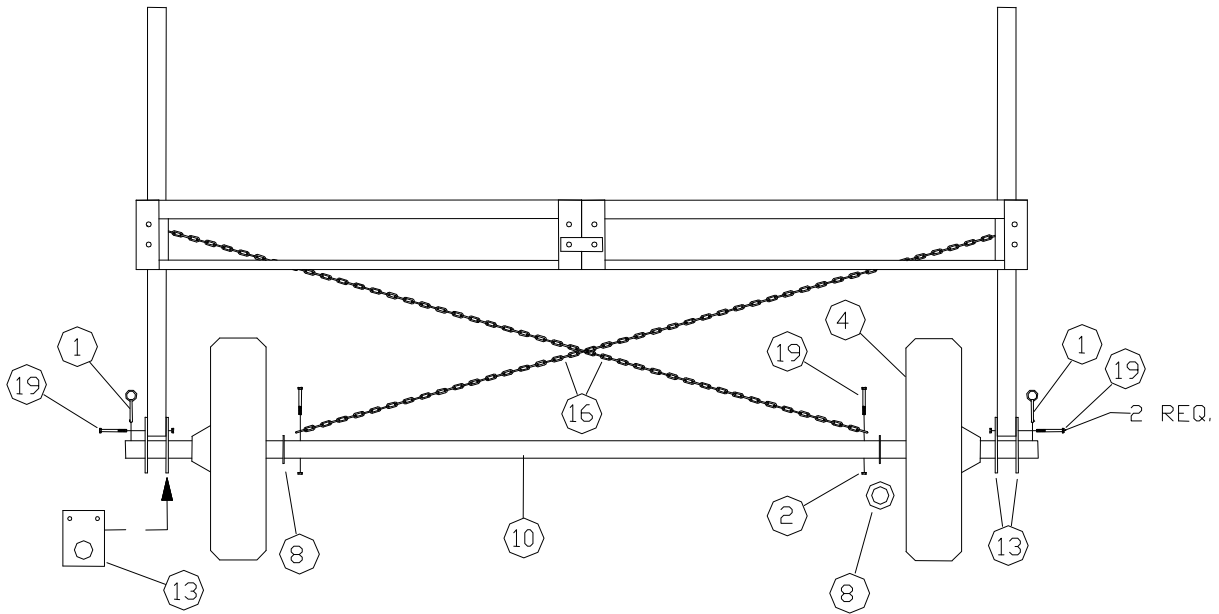

**Step 4.** Bolt on winch handles (**REF. # 28**) with winch nut (**REF. #29**). Attach lower dock pulleys (**REF. # 14**) to the winch side of the dock pockets with 1/2" x 2 3/4" pin between pocket and ear tab. Starting winch cable (**REF. # 12**) from the outside of the winch, pass cable through the hole on the side of the drum with the gears. Run cable through lower pulley, then up to pulleys on vertical lift members, and down to the top 13/32" hole in the pocket and back through the bottom 13/32" hole. Fasten with 3/16" cable clamp (**REF. # 5**). Work winches until cables are raising dock. You must alternate winches as the dock moves up or down. Place VLM pulley cover (**REF. #23**) onto vertical lift member.

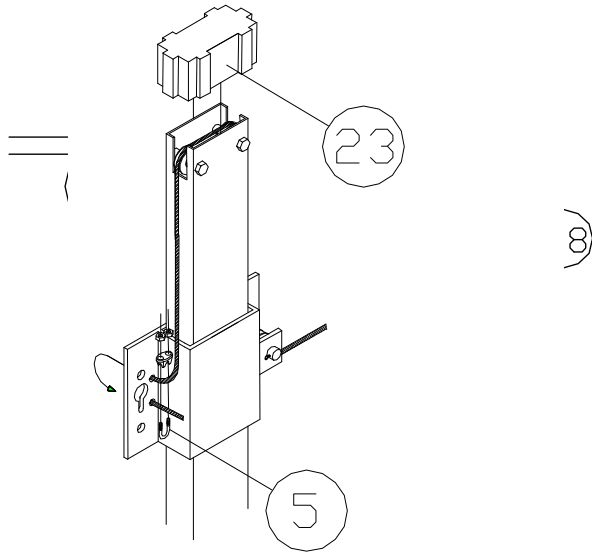

**Step 5.** Raise dock high enough to be able to work on it. **Caution: Before working under dock, be sure that the winches are locked and the set screws are tight.** Bring top of chain (**REF. # 16**) up to the opposite side of dock, through the keyhole bracket. Which is located on the vertical lift member pocket. Lock in position by sliding the chain link down the keyhole slot. If assembling an AA dock, bolt the center of the 8' section to the inside pocket of the 16' section, using 1/2" x 2 1/2" bolts and nuts (**REF. # 15 &3**)

**NOTE: If further adjustment of the dock height is necessary, loosen chains and set screws before adjusting.**

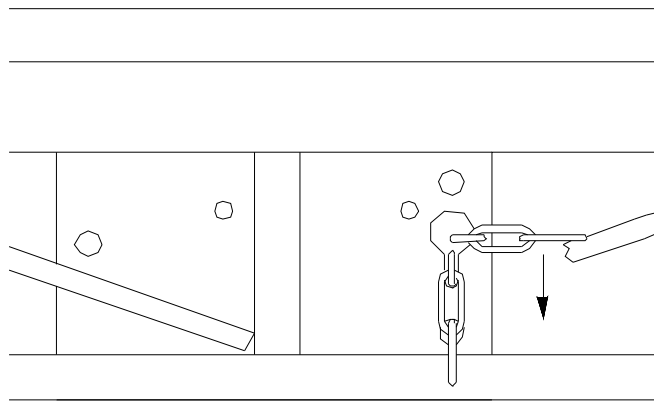

Before moving your dock into the water, make sure that the chains are not wrapped around the axle, and then pull the slack out of the chains by hooking them into the keyhole bracket. Roll your dock into position, and loosen the set screws on the VLM pocket. Adjust the dock to the desired height making sure that there is enough slack in the chains to accommodate the height you will be adjusting to. Once the desired height is reached, pull both the chains tight and then lower one side of the dock so the next link can be hooked into the keyhole slot and raise the dock back up to complete the tightening of the chain. Repeat on the other side. When finished with this, there should be no visible slack left in the chains, and they should be tight enough that you can't move them. Tighten the set screws in the VLM pocket.

The cross chains are to help control the side-to-side stability of the end of the dock and need to be tight. Once set they only need to be adjusted if the height of the dock is changed. **WARNING: before raising the dock it is necessary to loosen both of the chains and the set screws, or serious damage to the dock may occur.** When tightening the set screws, they should be tightened until they are snug against inside leg, and then tightened 1 1/2 to 2 turns more. Check the set screws after a couple of uses and retighten if necessary.

When moving dock into and from lake, lower dock to lowest level possible.

**AD05- DS 4'X 16'L8-AA / AP05- DS 4'X 16'L8-APD**  
**AW05- DS 4'X 16'L8-CPD ALUMINUM PORTA DOCK**

REF. #	PART NO.	DESCRIPTION	APD	CPD	AA
1	5245	1/4" X 2 1/2" PIN	2	2	2
2	5056	3/8" NUT	12	12	12
3	5058	1/2" NUT	14	14	14
4	4002	TIRE PLASTIC MOLDED	2	2	2
5	5003	3/16" CABLE CLAMP	2	2	2
6	5170	1/2" X 3/4" SET SCREW	2	2	2
7	30084	VERTICAL LIFT MEMBER	2	2	2
8	5077	WASHER 3"	2	2	2
9	10200	DOCK CONNECTOR BRACKET	2	2	2
10	30081	AXLE 98.50" L8 AA	-	-	1
	30091	AXLE 96" L8 APD/CPD	1	1	-
11	3005	WINCH DL1100	2	2	2
12	3050	CABLE 3/16" X 15'	2	2	2
13	30088	LIFT MEMBER BRACKET	4	4	4
14	3300	PULLEY SHEAVE 1 1/2"	6	6	6
15	5120	1/2" X 2 1/2" BOLT	6	6	6
16	3072	CHAIN 3/16" X 9'	2	2	2
17	5025	1/8" X 1" COTTER PIN	2	2	2
18	5081	3/8" X 1" BOLT	6	6	6
19	5084	3/8" X 3" BOLT	6	6	6
20	5126	1/2" X 1 1/4" BOLT	8	8	8
21	5008	1/2" X 2 3/4" PIN	2	2	2
23	3804	VLM PULLEY COVER	2	2	2
28	3008	DL WINCH HANDLE	2	2	2
29	5066	DL WINCH NUT	2	2	2
32	4112	8 1/2" AL VLM WEAR PAD	4	4	4
33	4108	ROLL FOAM TAPE 16'	5	-	-
35	5069	7/16" WASHER	16	16	16
	C120	AA COVER PLATE	-	-	1
38	3850	VLM COVER PLATE APD WHITE	2	-	-
	3851	VLM COVER PLATE APD BEIGE	2	-	-
	3852	VLM COVER PLATE CPD BROWN	-	2	-

**C120 AA COVER PLATE PKG**

<b>REF.NO</b>	<b>PART #</b>	<b>DESCRIPTION</b>	<b>APD</b>	<b>CPD</b>	<b>AA</b>
	5067	FENDER WASHER 3/8"			2
	5150	CARRIAGE BOLT 1/4" X 3/4" GR2	-	-	2
	5055	NUT FIN 1/4"	-	-	2
	10120	AA COVER PLATE 2.75" X 8" NEW '03	-	-	1

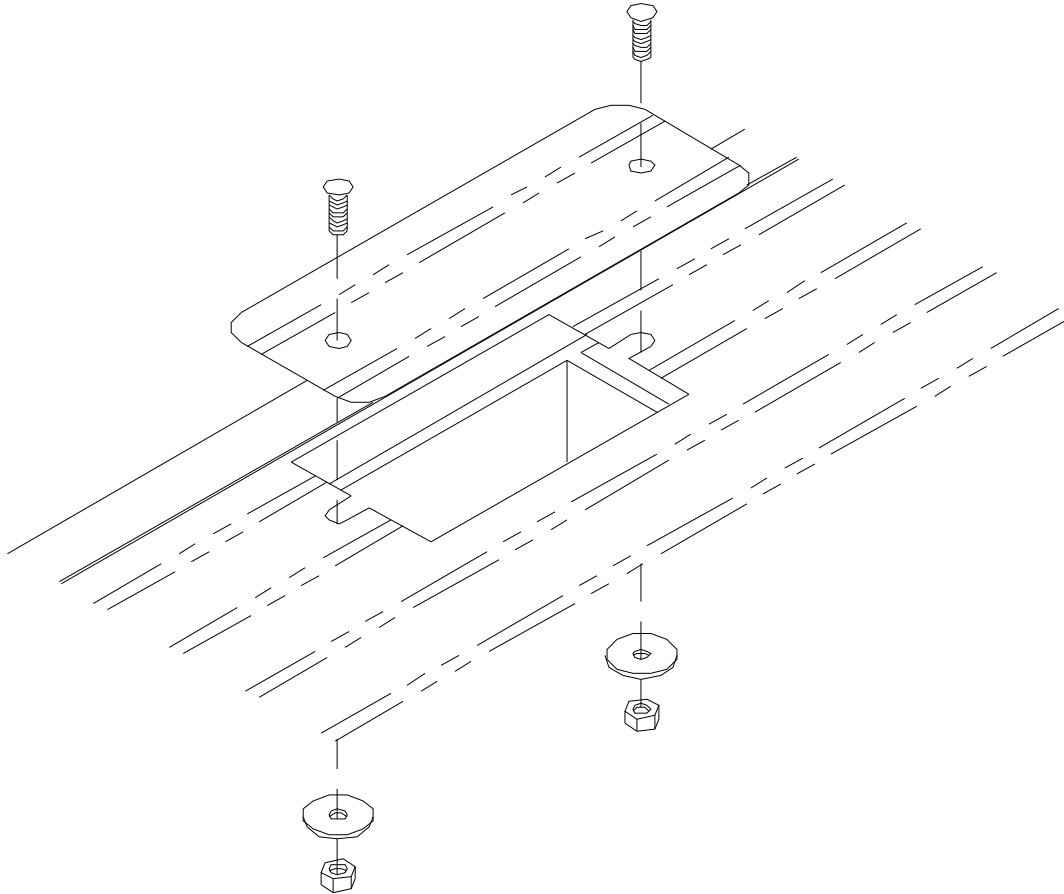

**FRAMES**

<b>PART#</b>	<b>DESCRIPTION</b>	<b>APD</b>	<b>CPD</b>	<b>AA</b>
M60	FRAME DS 4'X 16' APD/CPD WH END	1	1	-
M20	FRAME DS 4'X 16' AA WH END	-	-	1
M25	FRAME DS 4'X 8' AA L8-L	-	-	1
M68	FRAME DS 4'X 8' APD/CPD L8-L	1	1	-

**PANELS**

<b>PART#</b>	<b>DESCRIPTION</b>	<b>APD</b>	<b>CPD</b>	<b>AA</b>
B86 (B)	4'X 4' ALUM. PANEL STRAIGHT	2	-	-
B53	4'X 4' CEDAR PANEL STRAIGHT	-	2	-
B90 (B)	4'X 4' ALUM. PANEL RIGHT CUTOUT	2	-	-
BB61	4'X 4' CEDAR PANEL RIGHT CUT OUT	-	2	-
B89 (B)	4'X 4' ALUM. PANEL LEFT CUT OUT	2	-	-
BB62	4'X 4' CEDAR PANEL LEFT CUT OUT	-	2	-



## Wheel dock height adjustment instructions

Before moving your dock into the water, make sure that the chains are not wrapped around the axle, and then pull the slack out of the chains by hooking them into the keyhole bracket. Roll your dock into position, and loosen the set screws on the VLM pocket. Adjust the dock to the desired height making sure that there is enough slack in the chains to accommodate the height you will be adjusting to. Once the desired height is reached, pull both the chains tight and then lower one side of the dock so the next link can be hooked into the keyhole slot and raise the dock back up to complete the tightening of the chain. Repeat on the other side. When finished with this, there should be no visible slack left in the chains, and they should be tight enough that you can't move them. Tighten the set screws in the VLM pocket.

The cross chains are to help control the side-to-side stability of the end of the dock and need to be tight. Once set they only need to be adjusted if the height of the dock is changed. **WARNING: before raising the dock it is necessary to loosen both of the chains and the set screws, or serious damage to the dock may occur.** When tightening the set screws, they should be tightened until they are snug against inside leg, and then tightened 1 1/2 to 2 turns more. Check the set screws after a couple of uses and retighten if necessary.

When moving dock into and from lake, lower dock to lowest level possible.