

## **PORTA-DOCK, INC.**

### **A102 APD T15 5' X 16' ALUMINUM PORTA-DOCK** **A103 CPD T15 5' X 16' ALUMINUM PORTA-DOCK**

**\*For Beige Decking Add the Letter B to Model\***

**Thank you for purchasing our product!**

**\*Please read these instructions and follow them step by step. \***

**STEP 1.** Slide two support posts (**REF. # 24**) into the two outside corner pockets of each 8' section. Bolt an 8' section to each side of the 16' wheel end section using 1/2" x 1 1/4" bolts, washers, and nuts (**REF. # 20, 36 & 3**). Bolt the dock connector brackets (**REF. # 9**) to the lower end holes of the angle with 1/2" x 1 1/4" bolts, washers and nuts. Put the set screws (**REF. # 6**) into the pockets. Bolt the center of the outside 8' sections to the inside pockets of the 16' section using 1/2" x 2 1/2" bolts and nuts (**REF. # 15 & 3**). Once the dock is bolted together, lift it 2 to 3 feet off the ground, adjust the posts and tighten set screws.

Bolt winch (**REF. # 11**) with 3/8" x 1" bolts and nuts (**REF. # 18 & 2**) to the winch plate with winch handle stub to the outside. Then bolt winch on in the same manner to the outside side of the section.

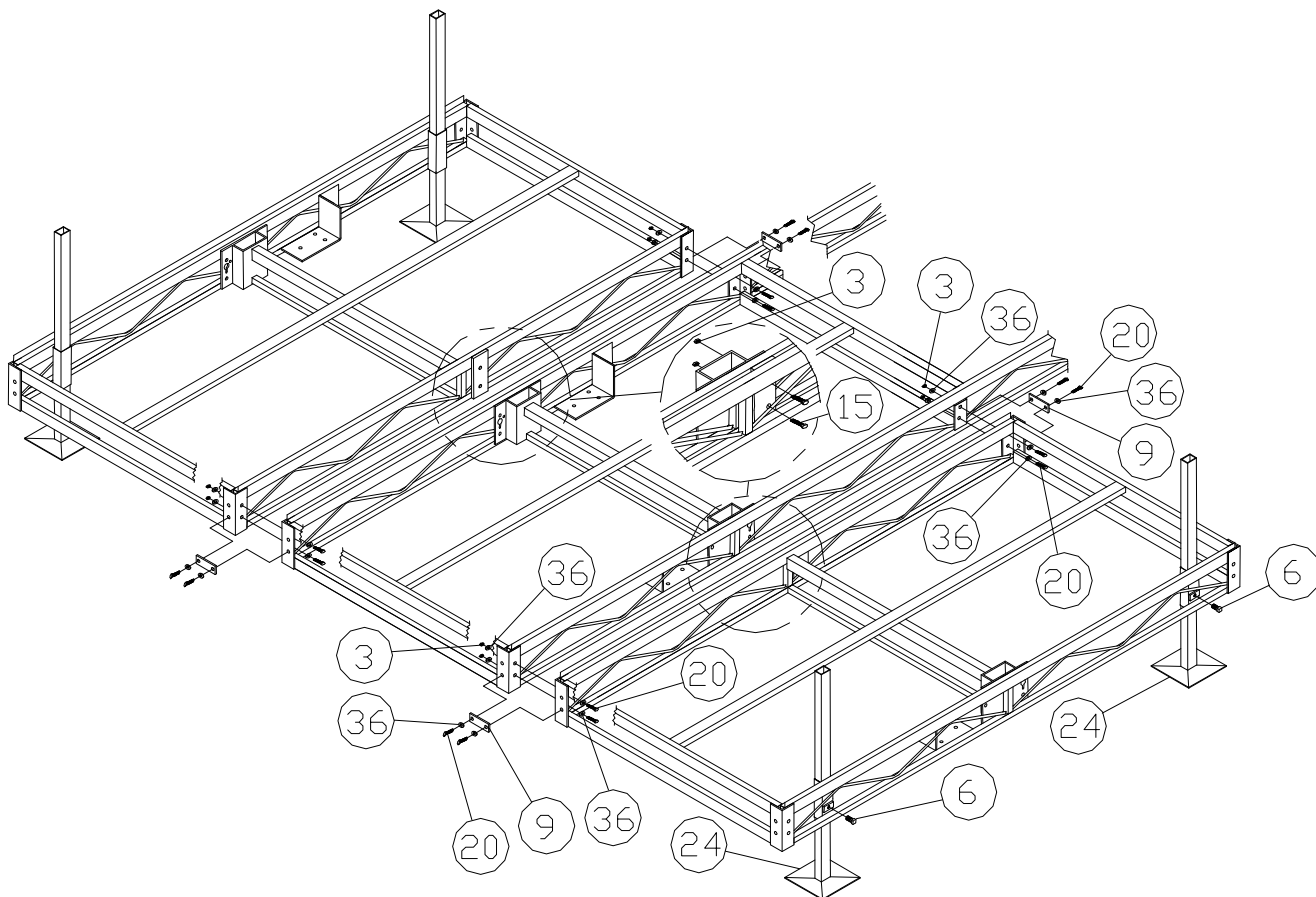
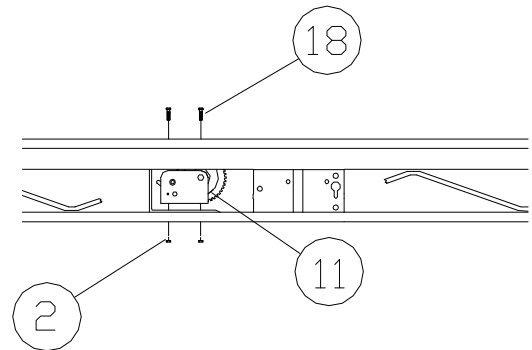

**STEP 2.** Apply the four nylon wear strips (**REF. # 33**) to the inside narrow ends of the large vertical lift member pockets. Pockets should be clean and dry and above 50 degrees. Slide a VLM cover plate (**REF. # 38**) onto each vertical lift member. Attach the dock pulleys (**REF. # 14**) with 1/2" x 2 1/2" bolts and nuts (**REF. # 15 and 3**) to top of vertical lift members (**REF. # 7**). Insert vertical lift members into pockets on each side of dock. Screw in set screws, leave loose at this time.

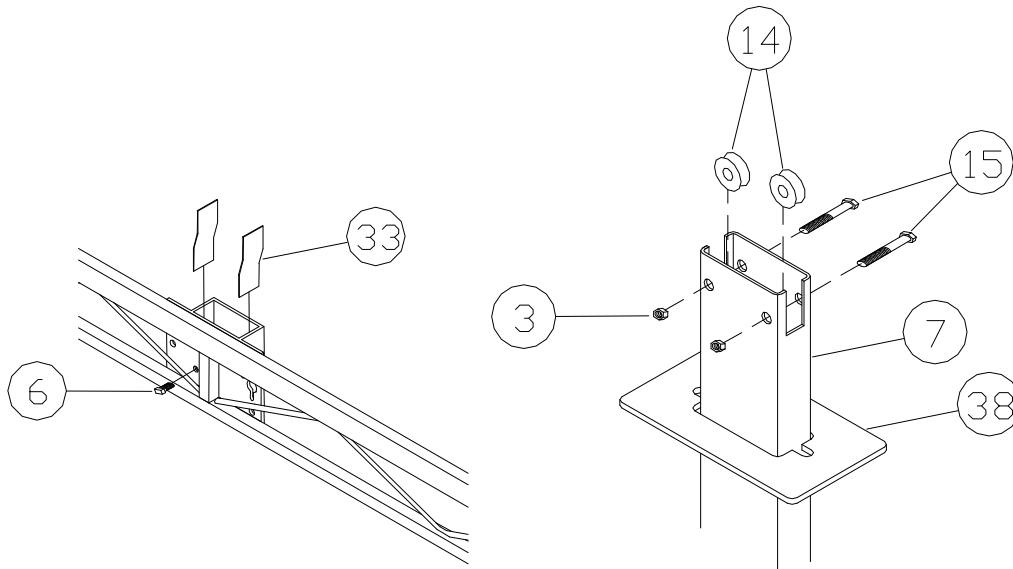

**STEP 3.** Attach the chains (**REF. # 16**) to the inside holes of the axle (**REF. # 10**) with a 3/8" x 3" bolt and nut (**REF. # 19 & 2**). Slide on the 3" washers (**REF. # 8**) then the dock wheels (**REF. # 4**) with the protruding hub to the outside onto the axle up to the chains, and then slide on the lift member brackets (**Ref. #13**). Place the 1/4" x 2 1/2" pin (**Ref. #1**) into the holes in the ends of the axle. Roll axle under dock, keeping axle centered with dock. Bolt lift member bracket (**Ref. #13**) to vertical lift members (**Ref. #7**) with 3/8" x 3" bolts and nuts (**Ref. #19 & 2**).

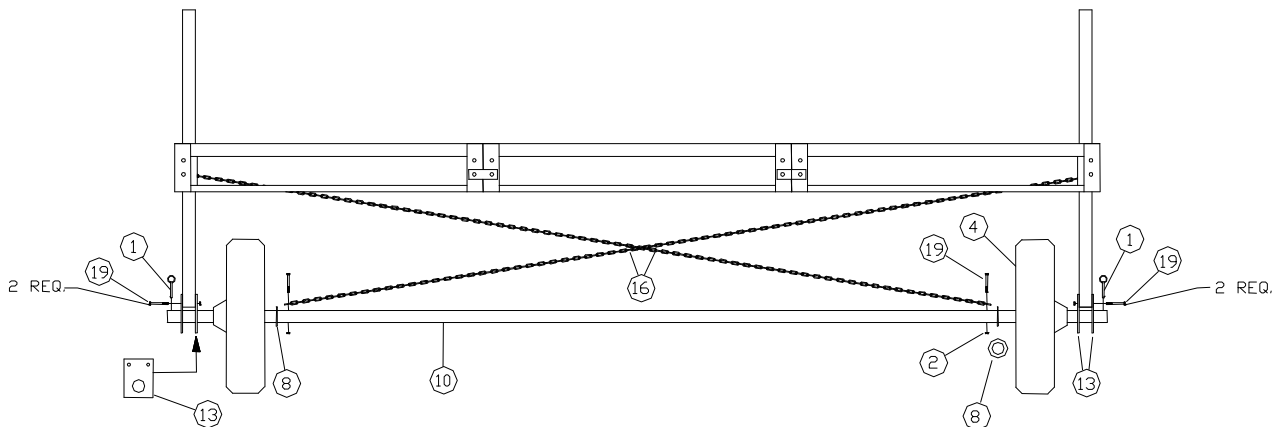

**STEP 4.** Bolt on winch handles (**Ref. #28**) with winch nut (**Ref. #29**). Attach lower dock pulleys (**Ref. #14**) to the winch side of the dock pockets with 1/2" x 2 3/4" pin between pocket and ear tab. Starting winch cable (**REF. # 12**) from the outside of the winch, pass cable through the hole on the side of the drum with the gears. Run the cable through lower pulley, then up to the pulleys on the vertical lift members, and down to the top 13/32" hole in the pocket and back through the bottom 13/32" hole. Fasten with 3/16" cable clamp (**REF. # 5**). Work winches until cables are raising dock. You must alternate winches as the dock moves up or down. Place VLM pulley cover (**Ref. #23**) onto the vertical lift member.

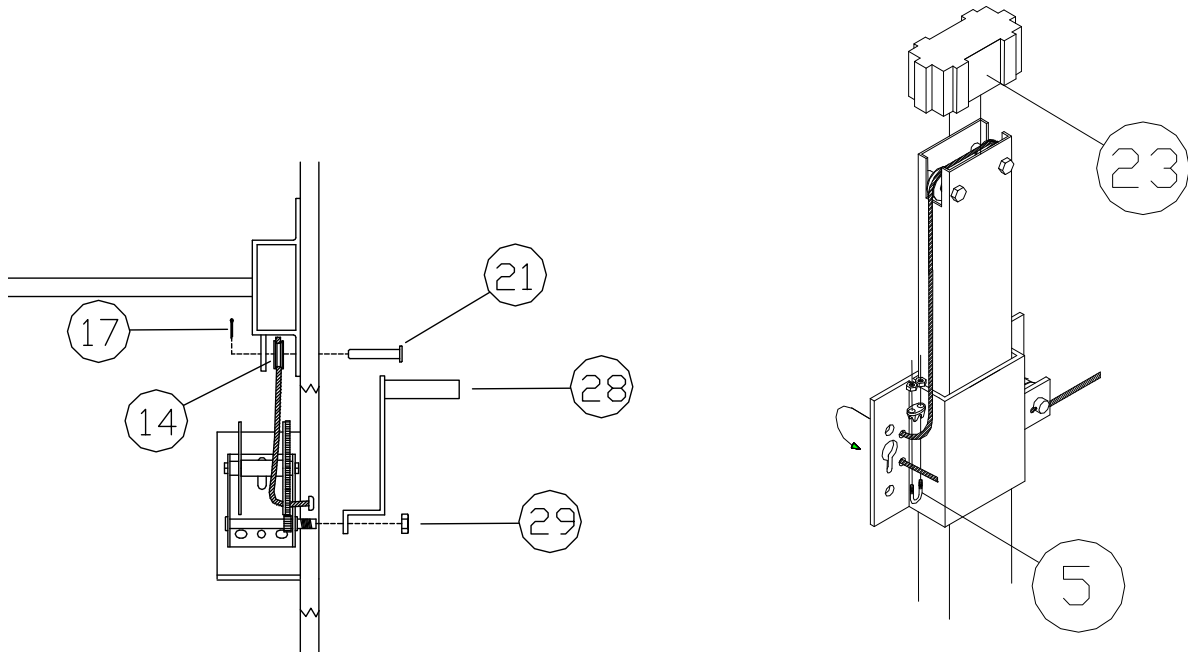

**STEP 5.** Raise dock high enough to be able to work on it. **CAUTION: Before working under dock, be sure that the winches are locked and the set screws are tight.** Bring top of chain (**REF. # 16**) up to the opposite side of dock, through the keyhole bracket, located on the vertical lift member pocket and lock in position by sliding the chain link down the keyhole slot.  
**NOTE:** If further adjustment of dock height is necessary loosen chains and set screws before adjusting.

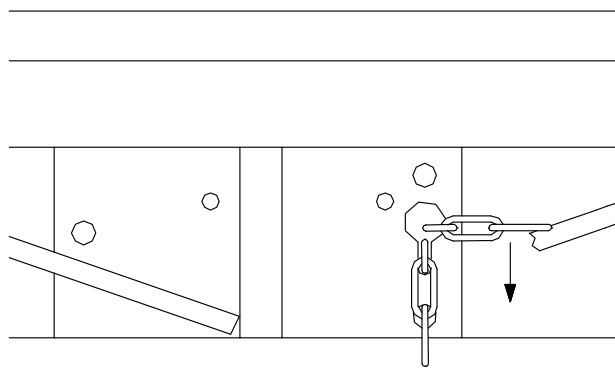

**STEP 6** Place the truss bar (**REF. # 1**) underneath the docks frame so that is about 16" in front of the vertical lift member.

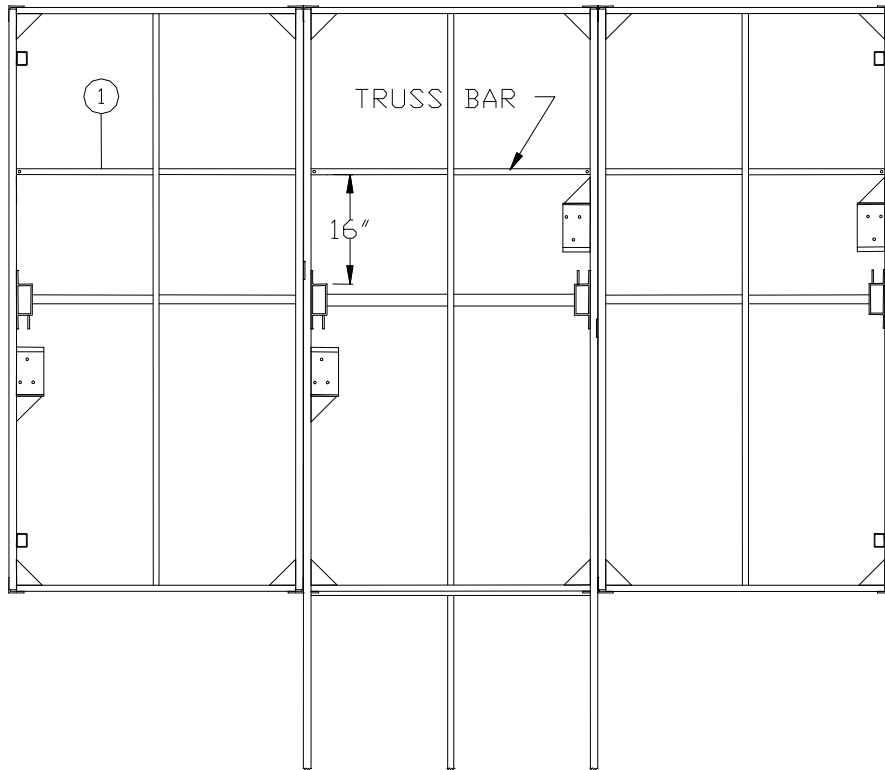

**STEP 7.** Fasten truss bar to the bottom one-inch square tube of the docks frame with the three J-hooks, 5/16" washers and lock nuts (**REF. # 2, 3 & 4**) as shown.

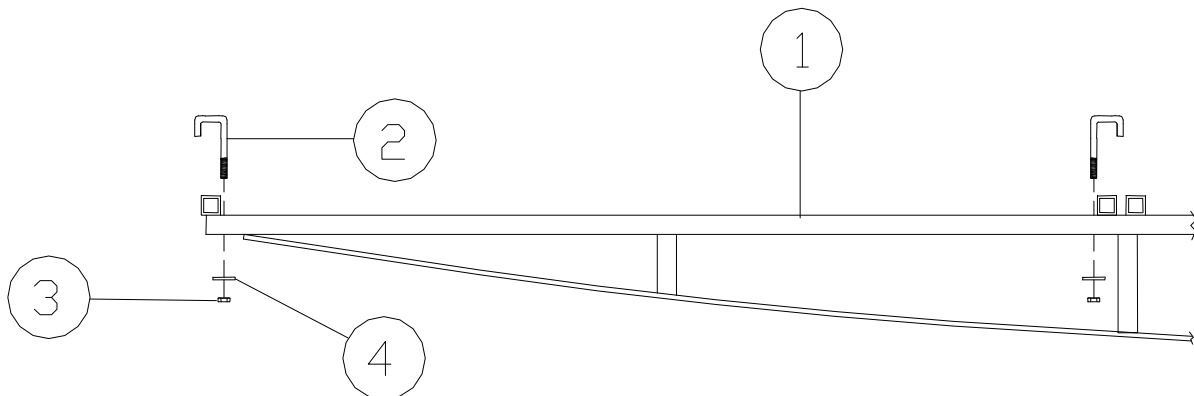

**NOTE:** After the panels are installed on the dock, slide a cover plate (**Ref. #37**) down each dock post and onto the deck. Place a rectangular post cap (**Ref. #25**) onto each post.

Before moving your dock into the water, make sure that the chains are not wrapped around the axle, and then pull the slack out of the chains by hooking them into the keyhole bracket. Roll your dock into position, and loosen the set screws on the VLM pocket. Adjust the dock to the desired height making sure that there is enough slack in the chains to accommodate the height you will be adjusting to. Once the desired height is reached, pull both the chains tight and then lower one side of the dock so the next link can be hooked into the keyhole slot and raise the dock back up to complete the tightening of the chain. Repeat on the other side. When finished with this, there should be no visible slack left in the chains, and they should be tight enough that you can't move them. Tighten the set screws in the VLM pocket.

The cross chains are to help control the side-to-side stability of the end of the dock and need to be tight. Once set they only need to be adjusted if the height of the dock is changed. **WARNING: before raising the dock it is necessary to loosen both of the chains and the set screws, or serious damage to the dock may occur.** When tightening the set screws, they should be tightened until they are snug against inside leg, and then tightened 1 ½ to 2 turns more. Check the set screws after a couple of uses and retighten if necessary.

When moving dock into and from lake, lower dock to lowest level possible.

**A100 5' X 16' L15 APD**  
**A101 5' X 16' L15 CPD**

REF. #	PART NO.	DESCRIPTION	QUANTITY		
			APD	APD-B	CPD
1	5245	¼" x 2 ½" PIN	2	2	2
2	5056	3/8" NUT	12	12	12
3	5058	½" NUT	24	24	24
4	4002	TIRE PLASTIC MOLDED	2	2	2
5	5003	3/16" CABLE CLAMP	2	2	2
6	5170	½" X ¾" SET SCREW	4	4	4
7	30084	VERTICAL LIFT MEMBER	2	2	2
8	5077	3" WASHER	2	2	2
9	10200	DOCK CONNECTOR BRACKET	4	4	2
10	30182	AXLE FOR APD, CPD L15	1	1	1
11	3005	WINCH DL1100	2	2	2
12	3050	CABLE 3/16" X 15'	2	2	2
13	30088	LIFT MEMBER BRACKET	4	4	4
14	3300	PULLEY SHEAVE 1 ½"	6	6	6
15	5120	½" X 2 ½" BOLT	8	8	8
16	3092	CHAIN 3/16" X 17'	2	2	2
17	5025	1/8" X 1" COTTER PIN	2	2	2
18	5081	3/8" X 1" BOLT	6	6	6
19	5084	3/8" X 3" BOLT	6	6	6
20	5126	½" X 1 ¼" BOLT	16	16	16
21	5008	½" X 2 ¾" PIN	2	2	2
23	3804	VLM PULLEY COVER	2	2	2
24	C30	8'ALUMINUM DOCK POST	2	2	2
25	3803	RECTANGULAR POST CAP	2	2	2
28	3008	DL WINCH HANDLE	2	2	2
29	5066	DL WINCH NUT	2	2	2
33	4112	8 ½" VLM WEAR PAD	4	4	4
34	4108	FOAM TAPE- 16' ROLL	8	8	-
36	5069	7/16" WASHER	32	32	32
37	3840	COVER PLATE APD WHITE	2	2	-
	3845	COVER PLATE APD BEIGE	2	2	-
	3841	COVER PLATE CPD BROWN	-	-	2
38	3850	VLM COVER PLATE APD WHITE	2	-	-
	3851	VLM COVER PLATE APD BEIGE	-	2	-
	3852	VLM COVER PLATE CPD BROWN	-	-	2

**TRUSS BAR**

<b>REF. #</b>	<b>PART NO.</b>	<b>DESCRIPTION</b>	<b>APD</b>	<b>CPD</b>
1	F73	APD, CPD TRUSS BAR	1	1
2	5031	5/16" J-BOLT	4	4
3	5068	5/16" WASHER	4	4
4	5054	5/16" NUT	4	4

**FRAMES**

<b>REF. #</b>	<b>PART NO.</b>	<b>DESCRIPTION</b>	<b>APD</b>	<b>CPD</b>
32	E89	5' X 8' APD/CPD L12 CENTER SECT.	1	1
30	F97	5' X 8' APD/CPD L15 L-SECTION	2	2

**PANELS**

<b>REF. #</b>	<b>PART NO.</b>	<b>DESCRIPTION</b>	<b>APD</b>	<b>CPD</b>
	B13 (B)	5'X 4' ALUM PL STRAIGHT	4	-
	B10	5'X 4' CEDAR PL STRAIGHT	-	4
	B81 (B)	5'X 4' ALUM PL L10 RIGHT CUTOUT	2	-
	B69	5'X 4' CEDAR PL L10 RIGHT CUTOUT	-	2
	B73 (B)	5'X 4' ALUM PL L10 LEFT CUTOUT	2	-
	B68	5'X 4' CEDAR PL L10 LEFT CUTOUT	-	2



## Wheel dock height adjustment instructions

Before moving your dock into the water, make sure that the chains are not wrapped around the axle, and then pull the slack out of the chains by hooking them into the keyhole bracket. Roll your dock into position, and loosen the set screws on the VLM pocket. Adjust the dock to the desired height making sure that there is enough slack in the chains to accommodate the height you will be adjusting to. Once the desired height is reached, pull both the chains tight and then lower one side of the dock so the next link can be hooked into the keyhole slot and raise the dock back up to complete the tightening of the chain. Repeat on the other side. When finished with this, there should be no visible slack left in the chains, and they should be tight enough that you can't move them. Tighten the set screws in the VLM pocket.

The cross chains are to help control the side-to-side stability of the end of the dock and need to be tight. Once set they only need to be adjusted if the height of the dock is changed.

**WARNING: before raising the dock it is necessary to loosen both of the chains and the set screws, or serious damage to the dock may occur.** When tightening the set screws, they should be tightened until they are snug against inside leg, and then tightened 1 1/2 to 2 turns more. Check the set screws after a couple of uses and retighten if necessary.

When moving dock into and from lake, lower dock to lowest level possible.

Porta-Dock, Inc.