

**PORTA-DOCK, INC.**  
**ALUMINUM CANTILEVER LIFTS**

**213A 20113 GEAR DRIVE**

**305A 3095 GEAR DRIVE**

**395A 3095 CHAIN DRIVE**

**303A 30113 GEAR DRIVE**

**303AL 30113 LONG GEAR DRIVE**

**313A 30113 CHAIN DRIVE**

**313AL 30113 LONG CHAIN DRIVE**

**413A 40113 CHAIN DRIVE**

**413AL 40113 LONG CHAIN DRIVE**

Thank you for purchasing our product! Please read these instructions and follow them step by step.\*

**STEP 1.**

Separate and group like parts and fasteners together. Locate the four leveling legs with pads (**REF.NO. 1**) and the two side members (**REF.NO. 2 & 3**) slide the four leveling legs into the end upright tubes of the side members. Secure in place with 1/2" x 1" set screws (**REF.NO. 22**) on the 4000lb. models, use two set screws per leg. Set the side member approximately the same distance apart as what your lift width is (2095/3095 is 95" and 20113/30113/40113 is 113"). Make sure the rear gusset plate is to the outside and the small flat tabs on the bottom side tube are to the inside.

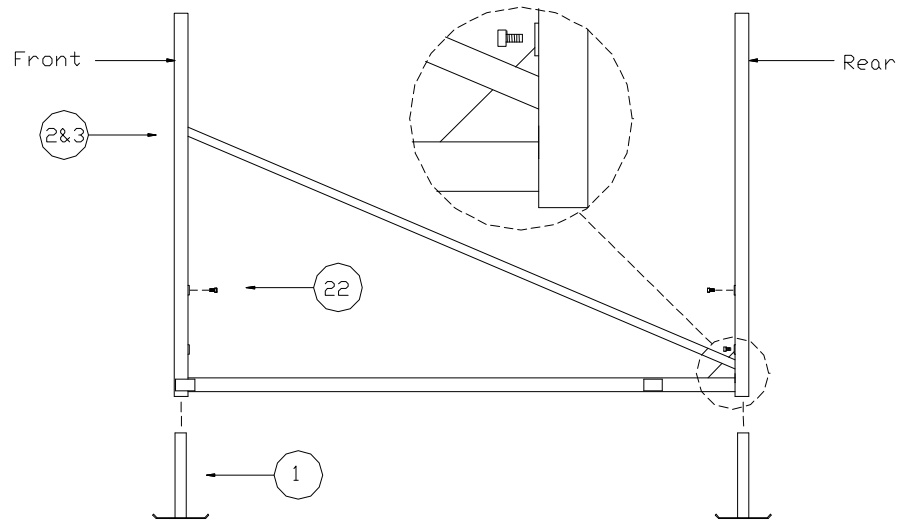

**STEP 2.**

Find the two bottom cross bar tubes (**REF.NO. 4**) (They're the ones with the end plates and channels welded on.) With the channel facing to the rear of the lift set them between the two side members so that the end plate is up against the end of the tabs that are welded on the bottom side tube. Fasten to bottom tube with the eight square U bolts and flange nuts. (**REF.NO. 23 & 24**) Finger tighten nuts. Using a tape measure, square the four corners of the uprights so that it is within about a 1/4" Tighten all U-bolt nuts.

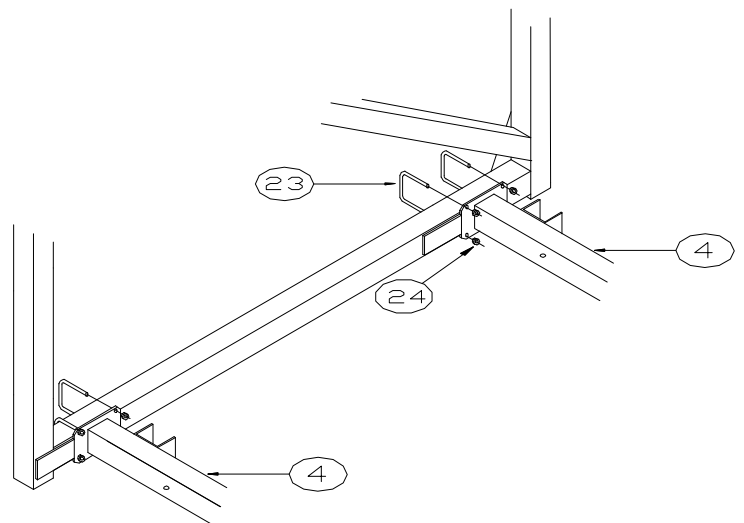

### STEP 3.

Locate the two H shape lifting arms (**REF.NO. 5**). Slide a brass pivot bushing (**REF.NO. 25**) into each pivot cap on the ends of the lifting arms. Place the lifting arm into the channels of the bottom cross tubes and fasten into place using 5/8" x 4 1/2" clevis pin and 5/8" washers. (**REF.NO. 26 & 27**) on 3000lb.-4000lb. models and 1/2" x 3" clevis pins and 1/2" washers on 1200lb.-2000lb. models. Secure with pins. (**REF.NO. 29**).

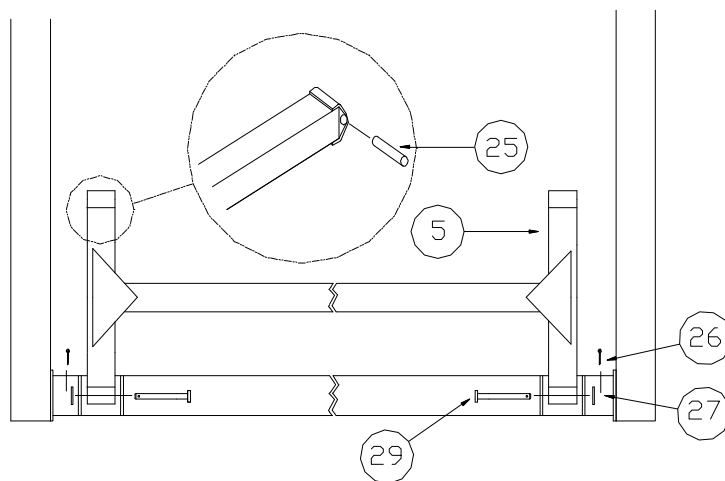

### STEP 4.

Find the front bed cross tube (**REF.NO. 6**) (the tube has large angles welded on the end that come up to the ends of the pivot channels) also, locate the bed pulley bracket (**REF.NO. 10**) and pulley-lifting arm, clevis pin and washers (**REF.NO. 28 & 27**). (5/8" X 7 1/2" clevis pin and 5/8" washers on 3000lb.-4000lb. models and 1/2" X 6" clevis pin 1/2" washers on 2000lb model) Place the pivot channels of the front bed cross tube into the ends of the front lifting arm. Place the pulley bracket so that the pulley sheave is toward the outside in between the corner angle and the pivot channel. From the outside pass the clevis pin through the angle, pulley bracket then through the two washers and lifting arm. Place another washer over the clevis pin and secure with pins (**REF.NO. 29**).

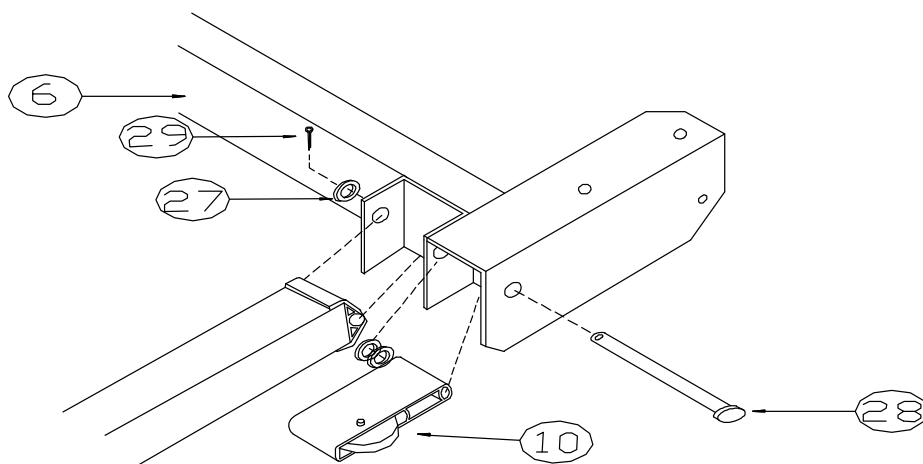

### STEP 5.

Fasten the rear bed cross tube (**REF.NO. 7**) to the rear lifting arms with clevis pin, washer, and pin. (**REF.NO. 26, 27 & 29**) (5/8" x 4 1/2" clevis pin on 3000-4000 lb. models and 1/2" x 3" clevis pin on 2000lb. models)

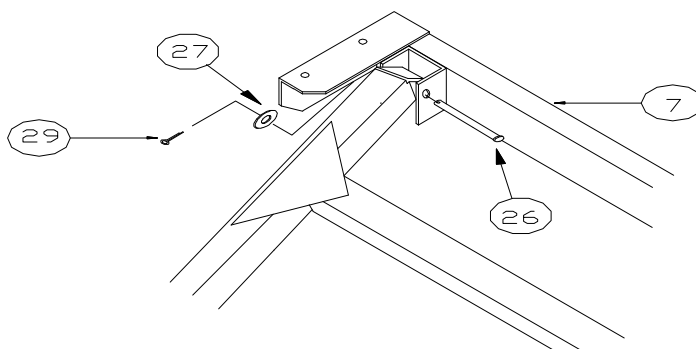

### STEP 6.

Locate the two top side rail tubes (**REF.NO. 8**) (2"X3" tube on 3000lb.-4000lb. models and 2"X2" tube on 2000lb. models) Bolt the side rail tube to the angles of the cross bed tubes with 1/2" x 4" bolts, washers and nuts on 3000lb.-4000lb. models and use 1/2" x 3" bolts, washers and nuts on 2000lbs. models. (**REF.NO. 30**)

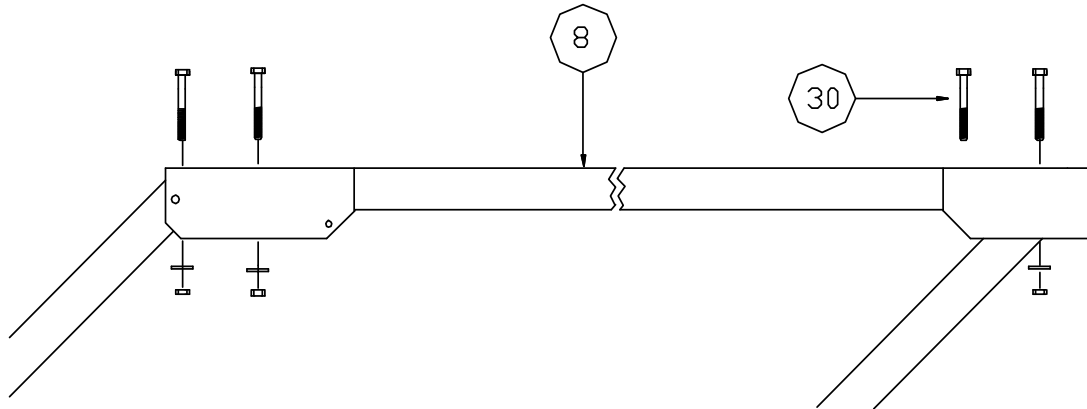

### STEP 7. GEAR DRIVE WINCH

Decide what side the winch (**REF.NO. 11**) is going on, the winch is simply turned over to go either left or right. Bolt the winch to the inside of the front upright using 3/8" fender washers (**REF.NO. 32**) on the tube side and standard 3/8" washers (**REF.NO. 33**) on the winch side. Use 3/8"x 3 1/2" bolts for 2000lb model, or 3/8"x 4" bolts on 3000lb. model (**REF.NO. 34**). Secure with 3/8" standard nut (**REF.NO. 38**). Find the lift cable (**REF.NO. 13**), thread the plain end of the cable through the hole in the side of the winch drum on the gear drive winch.

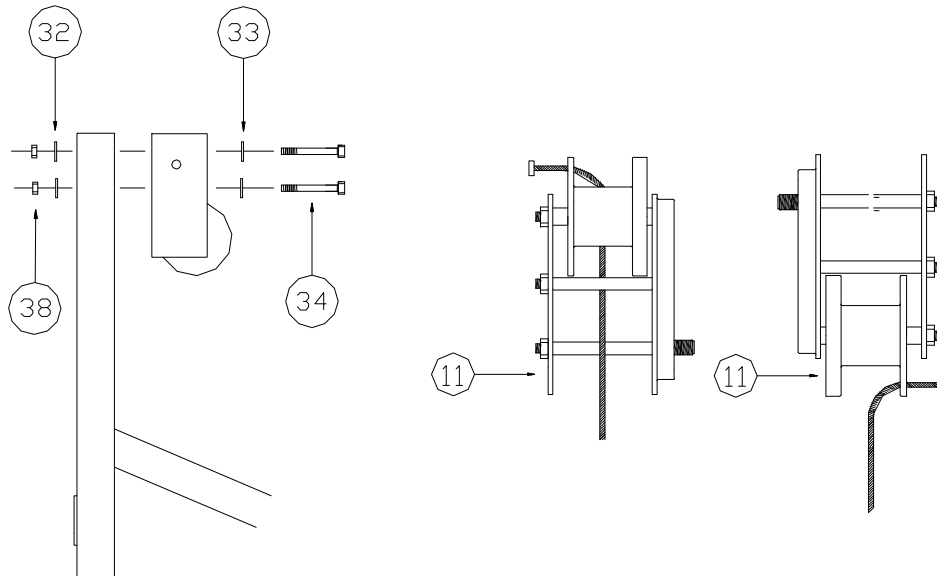

**STEP 7B. CHAIN DRIVE WINCH** Remove the light walled cover plate from the winch. Slide the winch (**Ref. No. 11**) onto the winch upright tube of the side member. Mount the winch using 3/8" x 4" bolts (for 3000 models) or 3/8" X 4 1/2" bolts (for 4000 models), washers, and nuts (**Ref. No. 34, 33, 38**). These should be loose at this time. Align the top hole in the winch and the upright tube so bolt slides in and out easily. Tighten bolts in mounting bracket. Then tighten the bolt in the upright tube with 3/8" fender washer, washer, and nut (**Ref. No. 32, 33, & 38**). Thread on the winch wheel, washer, and winch nut. Turn the wheel clockwise until the set screw that is in the face of the drum is toward the front edge of the winch. Loosen the allen head set screw in the face of the drum. Place the cable into the hole in the face of the drum, making sure that the cable goes into the sleeve inside the drum. Tighten the set screw and replace the outside cover. **NOTE: The drum of the winch must always be facing down (see below for changing winch so it will work with the opposite side).**

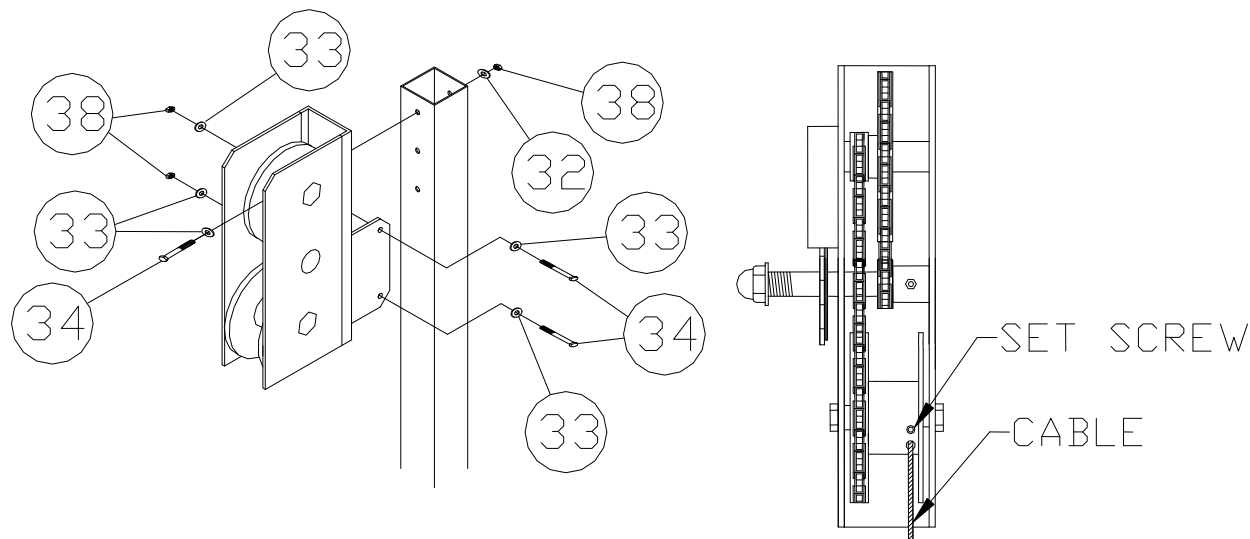

**CHANGING THE WINCH** Remove the light walled cover plate from the front of the winch by pulling out on the bottom. Remove the four 3/8" X 1" carriage bolts from the back mounting channel. Refasten the back mounting channel to the opposite side it was removed from. **NOTE: For easier installation the channel may be mounted to the winch upright before it is bolted back onto the winch.** Thread cable through pocket on side of winch drum as shown. Replace cover plate, thread on winch wheel, washer, and winch nut.

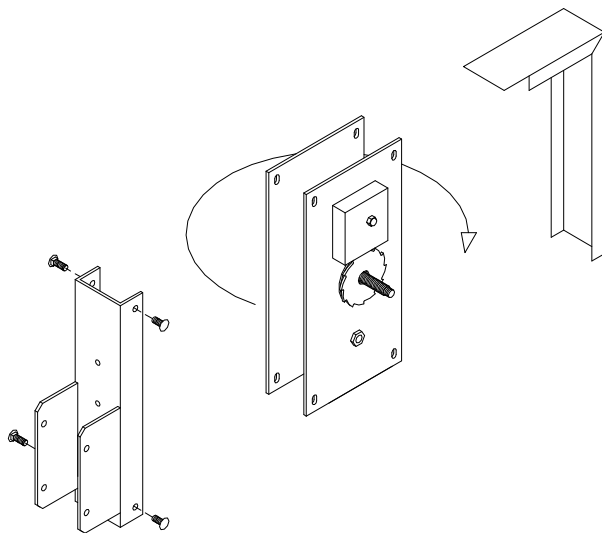

**STEP 8.** Locate the two round U-bolts (**REF.NO. 35**) and the one pulley and chain assembly (**REF.NO. 36**). Place the U-bolt through the chain link and into the two holes directly below the winch and diagonal tube of the side member. Secure the U-bolt with 7/16" washers and nylock nuts (**REF.NO. 32A & 37A**) on 3000lb.-4000lb. models and 3/8" fender washers and nylock nuts on 1200lb.-2000lb. models (**REF.NO. 32 & 37**). Only finger tighten nuts at this time. Place the other U-bolt through the cable thimble (**REF.NO. 40**) and secure to opposite side member in the same manner. Pass the cable through the hole in the diagonal brace tube and the pulley sheave in the pulley bracket below it. Now, run the cable up to and through the pulley on the front bed cross tube across to and through the other pulley. Bring the cable back up to the other U-bolt around the cable thimble and secure with cable clamps. (**REF. NO. 39**). On the 3000lb.-4000lb. models use two clamps. Install lift wheel (**REF.NO. 20**) on winch and secure with winch hardware. Turning lift wheel clockwise raise the bed of the lift 3/4 of the way up. Check the cable clearance in the hole of the diagonal brace tube of the side member. Adjust U-bolt nuts, if necessary, until cable is clear.

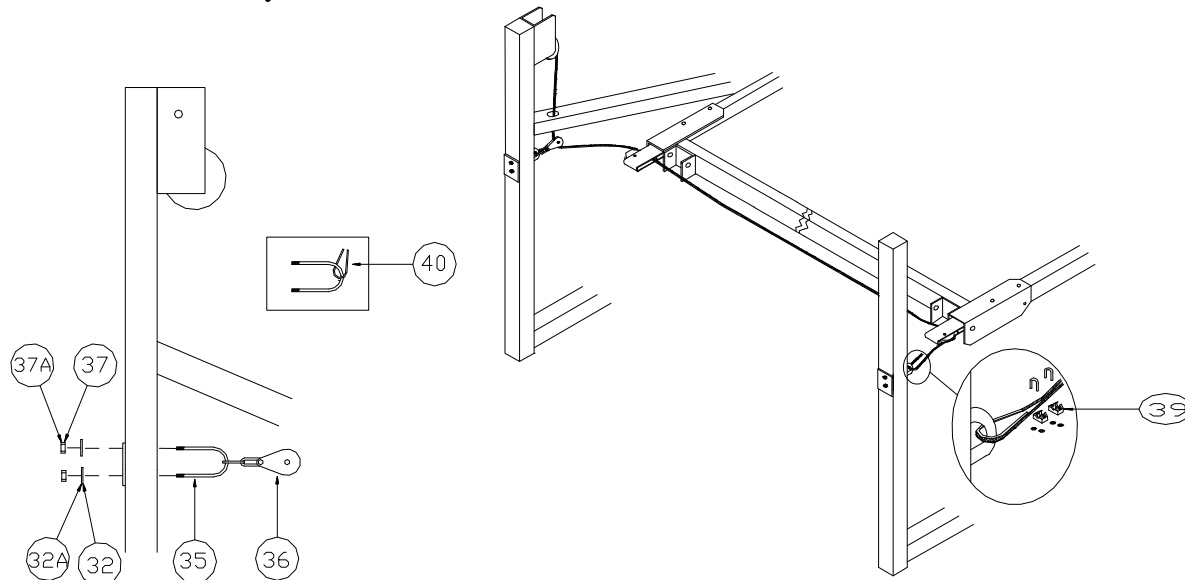

**STEP 9.** Find the two front angle braces (**REF.NO. 9**) (description 1/4"X 1 1/2" X 2"X 36" with slotted holes on each end) bolt the one end to the inside face of the front upright tube with a 3/8"x 4 1/2" bolt for 4000lb model, 3/8"x 4" bolt for 3000lb. model, 3/8"x 3 1/2" bolt for 2000lb. model. Use 3/8" washers and nuts. (**REF.NO. 34, 33 & 38**) Bolt the other end to the side of the bottom cross tube using the same size bolt, washer and nuts. Tighten up bottom cross member nut first so that the slot is about in the middle of the bolt. Check front upright for straightness. Adjust upright if necessary and tighten bolt in upright tube

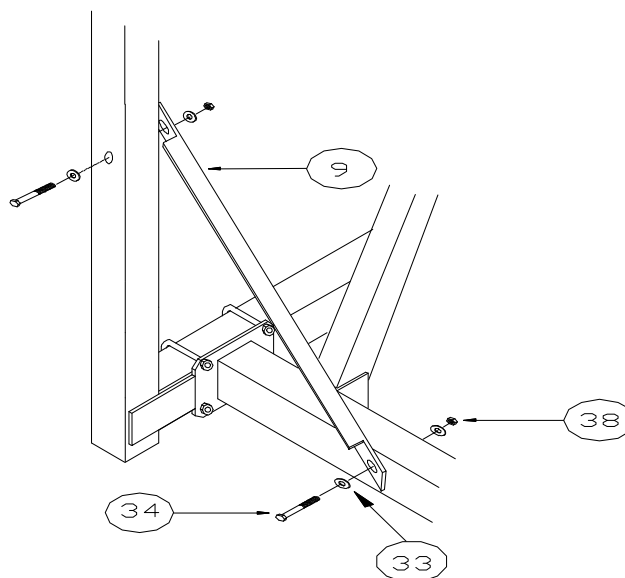

### STEP 10.

Take the two stop chains (**REF.NO. 14**) and bolt the one end to the bottom side of the diagonal brace tube of the side member using a 3/8" x 4" bolt for 4000lb. models, 3/8" x 3 1/2" bolt for 3000lb. models and 3/8" x 3" bolt for 2000lb. models. Place the chain link between two 3/8" washers and secure with a 3/8" nylock nut (**REF.NO. 41, 33, & 42**). Tighten enough so that the nylock nut is fully engaged with the thread of the bolt, yet chain should still turn freely. Fasten the other end of the chain to the inside of the bottom corner of the angle of the top bed cross tube with a 3/8" x 1 1/2" bolt, washers and nylock nut (**REF.NO. 43, 33, & 42**). Again tighten the nylock nut so that the nylon of the nut is engaged with the threads of the bolt, but the chain can still turn freely.

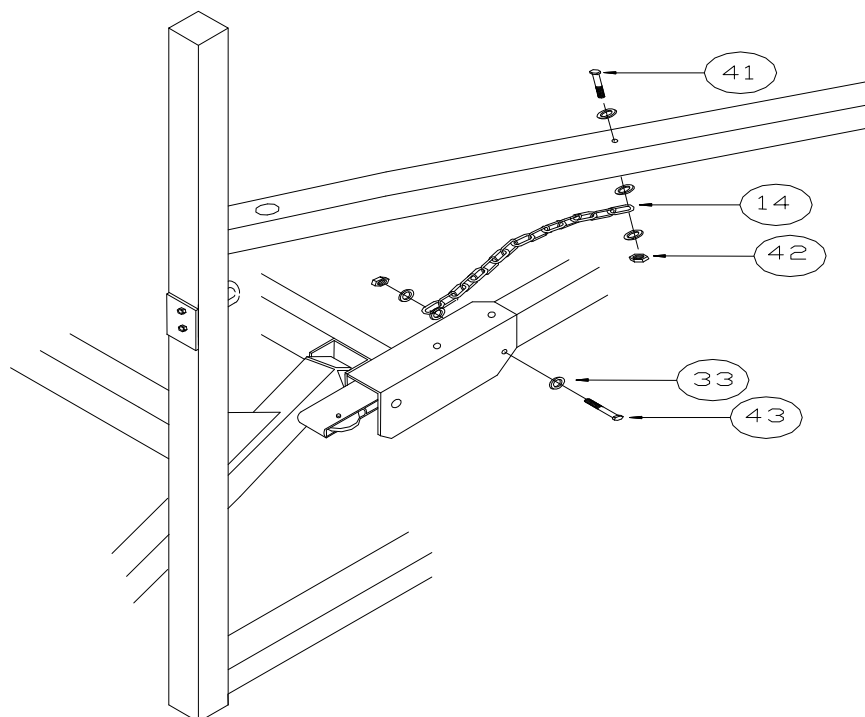

### STEP 11

Install lift wheel spinner knob (**REF.NO. 21**) to the half moon plate by the spoke. Raise and lower the lift a few times (**NOTE:** an empty bed may need to be pushed at first to get it to start lowering). Check for binding, check cable clearance in diagonal brace hole, and make sure all bolts have been tightened securely. Place safety caps (**REF.NO. 46**) over U bolt ends. After lift has been used several times, check all set screws and bolts, retighten if necessary.

## PARTS LIST 2000 LB. LIFTS

REF.NO.	PART NO.	DESCRIPTION	QTY
1	61H	LEVELING LEG	4
2	26E	SIDE MEMBER RIGHT	1
3	27E	SIDE MEMBER LEFT	1
4	20G	BOTTOM CROSS TUBE 2095	2
	21G	BOTTOM CROSS TUBE 20113	2
5	18G	LIFTING ARMS 2095	2
	19G	LIFTING ARMS 20113	2
6	29H	FRONT BED CROSS TUBE 2095	1
	22H	FRONT BED CROSS TUBE 20113	1
7	28H	REAR BED CROSS TUBE 2095	1
	27H	REAR BED CROSS TUBE 20113	1
8	41213	TOP SIDE RAIL	2
9	41202	DIAGONAL FRONT BRACE	2
10	99C	PULLEY BRACKET 3"	2
11	3016	WINCH 1502	1
13	3054	CABLE ¼" X 26'	1
14	3073	CHAIN STOP 3/16"X32 LINK	2
20	51E	LIFT WHEEL DL	1
21	4504	SPINNER KNOB	1
22	5174	SET SCREW ½" X 1"	4
23	5046	U BOLT SQ. X 2.75"	8
24	5156	FLANGE NUT 3/8"	16
25	3313	BRASS BUSHING 5/8" X 2"	8
26	5097	CLEVIS PIN ½" X 3"	6
27	5071	WASHER ½"	20
28	5096	CLEVIS PIN ½" X 6 ½"	2
29	5025	COTTER PIN 1/8" X 1 ¼"	8
30	5122	BOLT ½" X 3"	8
31	5058	NUT ½"	8
32	5067	FENDER WASHER 3/8"	6
33	5070	WASHER 3/8"	27
34	5085	BOLT 3/8" X 3 ½"	6
35	5049	U BOLT 3/8" ROUND	2
36	E75	PULLEY 2 ½" 2 LINK	1
37	5038	NUT 3/8" NYLOCK	8
38	5056	NUT 3/8" STANDARD	6
39	5004	CABLE CLAMP ¼"	1
40	5044	CABLE THIMBLE ¼"	1
41	5084	BOLT 3/8" X 3"	2
43	5155	BOLT 3/8" X 1 ½"	2
46	3828	CAP 3/8"	4
48	3822	CAP 2 ½" SQUARE GRAY	3

## PARTS LIST 3000 LB. LIFTS

REF. NO.	PART NO.	DESCRIPTION	QTY
1	60H	LEVELING LEG	4
2	21E	SIDE MEMBER RIGHT	1
3	22E	SIDE MEMBER LEFT	1
4	22G	BOTTOM CROSS TUBE 3095	2
	23G	BOTTOM CROSS TUBE 30113	2
5	26H	LIFTING ARMS 3095	2
	26G	LIFTING ARMS 30113	2
6	24H	FRONT BED CROSS TUBE 3095	1
	24E	FRONT BED CROSS TUBE 30113	1
7	23H	REAR BED CROSS TUBE 3095	1
	25E	REAR BED CROSS TUBE 30113	1
8	41000	TOP SIDE RAIL	2
9	41202	DIAGONAL FRONT	2
10	99D	PULLEY BRACKET 3 1/2"	2
11	3003	WINCH 2503	1
12	3H	WINCH CHAIN DRIVE 11-1	1
13	3054	CABLE 1/4" X 26'	1
14	3073	CHAIN STOP 3/16" X 32 LINK	2
20	51E/45F	LIFT WHEEL DL/CHAIN DRIVE	1
21	4504	SPINNER KNOB	1
22	5174	SET SCREW 1/2" X 1"	4
23	5047	U BOLT SQ. X 3.50"	8
24	5158	FLANGE NUT 7/16"	16
25	3312	BRASS BUSHING 3/4" X 3"	8
26	5095	CLEVIS PIN 5/8" X 4 1/2"	6
27	5072	WASHER 5/8"	12
28	5098	CLEVIS PIN 5/8" X 7 1/2"	2
29	5025	COTTER PIN 1/8" X 1 1/4"	8
30	5112	BOLT 1/2" X 4"	8
31	5058	NUT 1/2"	8
32	5067	FENDER WASHER 3/8"	2
32A	5069	WASHER 7/16"	4
33	5070	WASHER 3/8"	27
34	5089	BOLT 3/8" X 4"	6
35	5050	U-BOLT 7/16" ROUND	2
36	E90	PULLEY 3" 2 LINK	1
37	5038	NUT 3/8" NYLOCK	4
37A	5171	NUT 7/16" NYLOCK	4
38	5056	NUT 3/8" STANDARD	6
39	5004	CABLE CLAMP 1/4"	2
40	5044	CABLE THIMBLE 1/4"	1
41	5085	BOLT 3/8" X 3 1/2"	2
43	5155	BOLT 3/8" X 1 1/2"	2
46	3826	CAP .406 X .50"	4
49	5071	WASHER 1/2"	8
50	3823	CAP 3" SQUARE GRAY	3

## PARTS LIST 4000 LB. LIFTS

REF. NO.	PART NO.	DESCRIPTION	QTY
1	58H	LEVELING LEG	4
2	20E	SIDE MEMBER RIGHT	1
3	29G	SIDE MEMBER LEFT	1
4	24G	BOTTOM CROSS TUBE 40113	2
5	26G	LIFTING ARMS 40113	2
6	28E	FRONT BED CROSS TUBE 40113	1
7	29E	REAR BED CROSS TUBE 40113	1
8	41000	TOP SIDE RAIL	2
9	41202	DIAGONAL FRONT	2
10	99D	PULLEY BRACKET 3 1/2"	2
11	4H	CHAIN DRIVE WINCH 15-1	1
13	3047	CABLE 5/16" X 26'	1
14	3073	CHAIN STOP 3/16" X 32 LINK	2
20	45F	LIFT WHEEL CHAIN DRIVE	1
21	4504	SPINNER KNOB	1
22	5174	SET SCREW 1/2" X 1"	4
23	5048	U-BOLT SQ. 7/16" X 3" X 4"	8
24	5158	FLANGE NUT 7/16"	16
25	3312	BRASS BUSHING 3/4" X 3"	8
26	5095	CLEVIS PIN 5/8" X 4 1/2"	6
27	5072	WASHER 5/8"	12
28	5098	CLEVIS PIN 5/8" X 7 1/2"	2
29	5025	COTTER PIN 1/8" X 1 1/4"	8
30	5112	BOLT 1/2" X 4"	8
31	5058	NUT 1/2"	8
32	5067	FENDER WASHER 3/8"	2
32A	5069	WASHER 7/16"	4
33	5070	WASHER 3/8"	27
34	5087	BOLT 3/8" X 4 1/2"	7
35	5051	U-BOLT 7/16" ROUND	2
36	E90	PULLEY 3" 2 LINK	1
37	5038	NUT 3/8" NYLOCK	4
37A	5171	NUT 7/16" NYLOCK	4
38	5056	NUT 3/8" STANDARD	8
39	5078	CABLE CLAMP 5/16"	2
40	5099	CABLE THIMBLE 5/16"	1
41	5089	BOLT 3/8" X 4"	2
43	5155	BOLT 3/8" X 1 1/2"	2
46	3826	CAP .406" X .50"	4
49	5071	WASHER 1/2"	8
50	3824	CAP 3 1/2" SQUARE GRAY	3

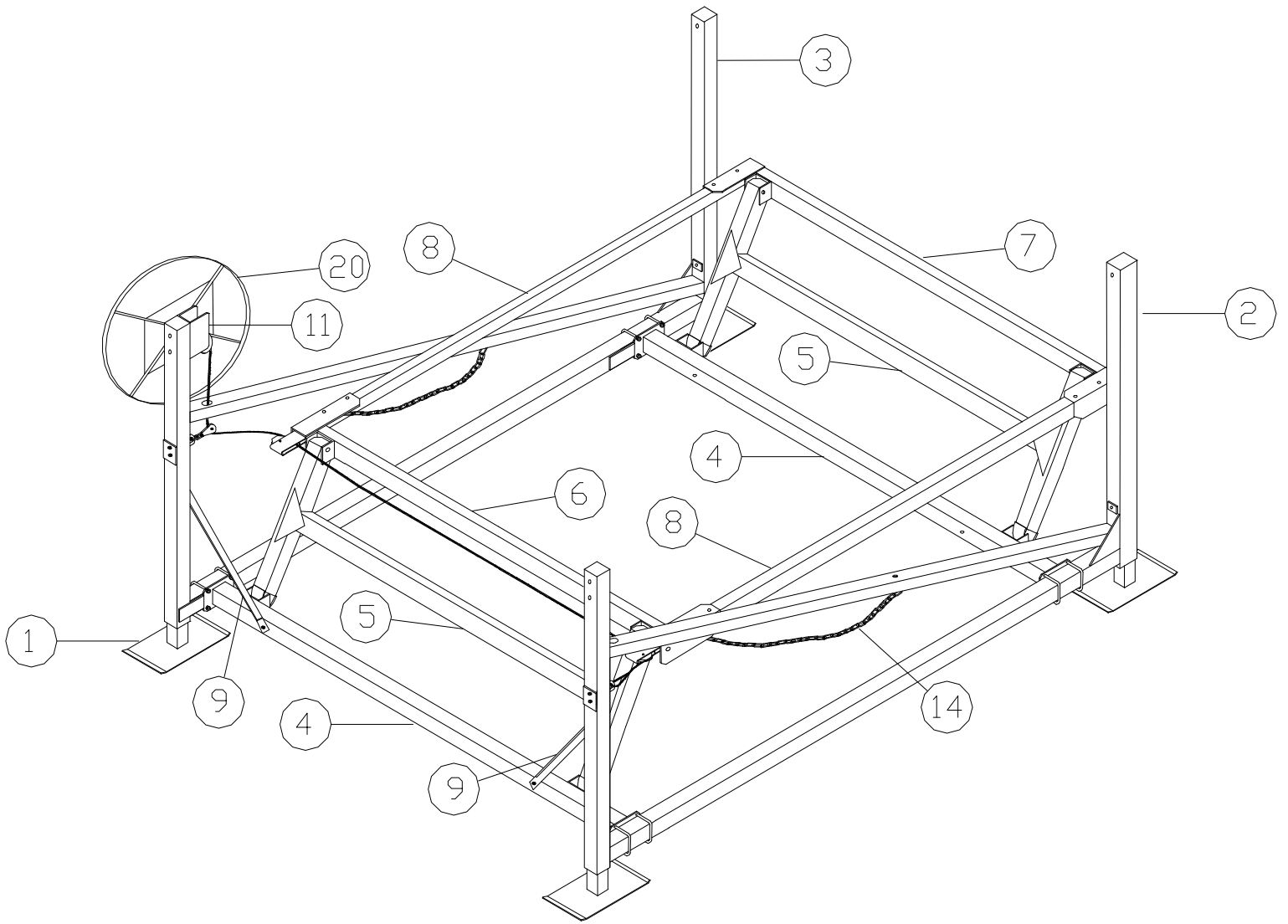



## IMPORTANT BOAT LIFT SAFEGUARDS

**The boat lift system must be assembled, installed and operated correctly or mechanical failure causing injury or death may occur. Be sure that all persons operating the lift are familiar with the correct operating procedures and safety guidelines.**

**CAUTION** - Keep all body parts inside the boat when entering or exiting the boat lift. Do not try to manually guide the boat into position.

**CAUTION** – Keep clear of chains, cables, and all moving parts when operating the lift.

**CAUTION** – On lifts that have a chain drive winch, the cover must be in place while operating.

**CAUTION** – Never allow anyone to swim around or climb on the lift structure at any time.

**CAUTION** – Do not operate the lift with people inside the boat.

**CAUTION** – Never exceed the rated capacity of the lift as this may cause excessive damage to the lift. Do not allow people to sit in a boat that is on the lift as this may cause to lifts capacity to be exceeded. An uncovered boat can fill up with water and cause the capacity of the lift to be exceeded.

**CAUTION** – Before any adjustments are made to the lift, or any work is done, the boat must be removed and the bed must be fully lowered.

**CAUTION** – Winches are pre set from the manufacturer and do not need adjusting.

**CAUTION** – If using a winch with a remote control, the operator must be close enough to the lift to be sure that no one is around or on the lift, and to be sure that the lift is operating properly

**CAUTION** - After installation the lift must be leveled in order to operate properly. If the lift is not leveled properly there will be excessive stress on isolated areas causing failure or damage to the lift.

Before installing the lift each year inspect the cables, pulleys, and all moving parts for wear. Immediately replace any part that has excessive wear. Check the brake pad in the winch, if it is worn down to 1/16” thick, cracked, or glazed over, replace it immediately. Check all the bolts to make sure they are tight. On vertical lifts the cables may stretch and will need to be tightened so there is equal tension on all the cables.

Porta-Dock, Inc.