

PORTA-DOCK, INC. 210A FLB VERTICAL 1265V LIFT W/ GEAR DRIVE WINCH

Thank you for purchasing our product!
Please read these instructions and follow them step by step.*

STEP 1. Separate and group like parts and fasteners together. Locate the winch side member with the longer upright tube and diagonal braces (**Ref. no. 1**). Lay this side member on its side with the corner angles up. Slide the leveling legs (**Ref. no. 4**) into the side member uprights. Secure in place with 1/2" X 3/4" set screws (**Ref. no. 19**). Repeat with the anchor side member.

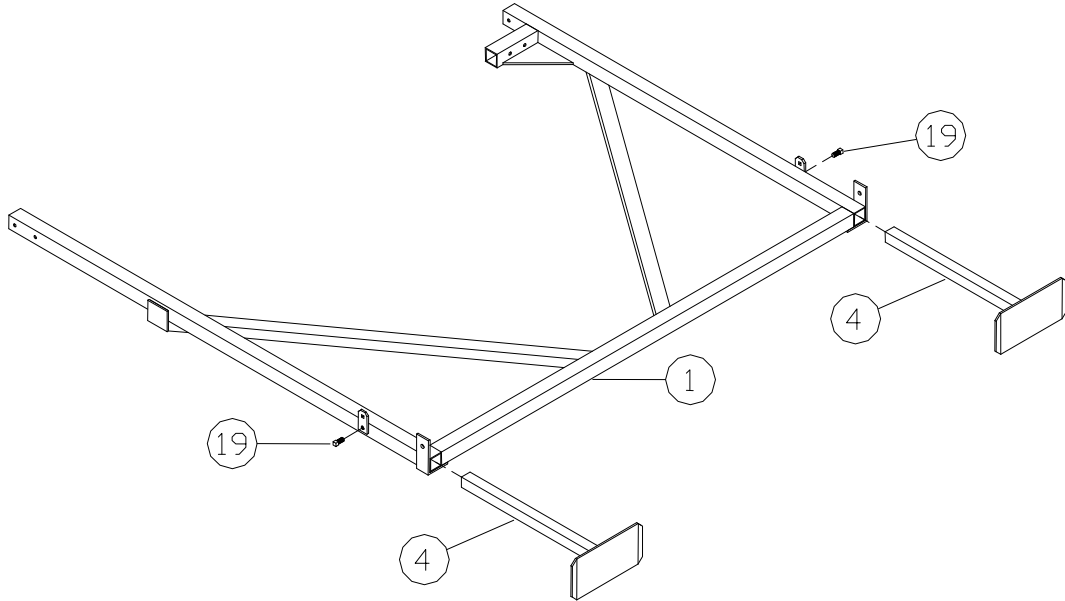

STEP 2. Locate the two 2 X 2" X 64 1/2" bottom cross tubes (**Ref. no. 5**) Using two people stand the side member up on it's leveling legs. With one person balancing the side member, bolt the bottom cross tube to the corner angles using 1/2" X 3" bolts, washers, and nuts (**Ref. no. 24, 25, & 26**). Leave nuts finger tight.

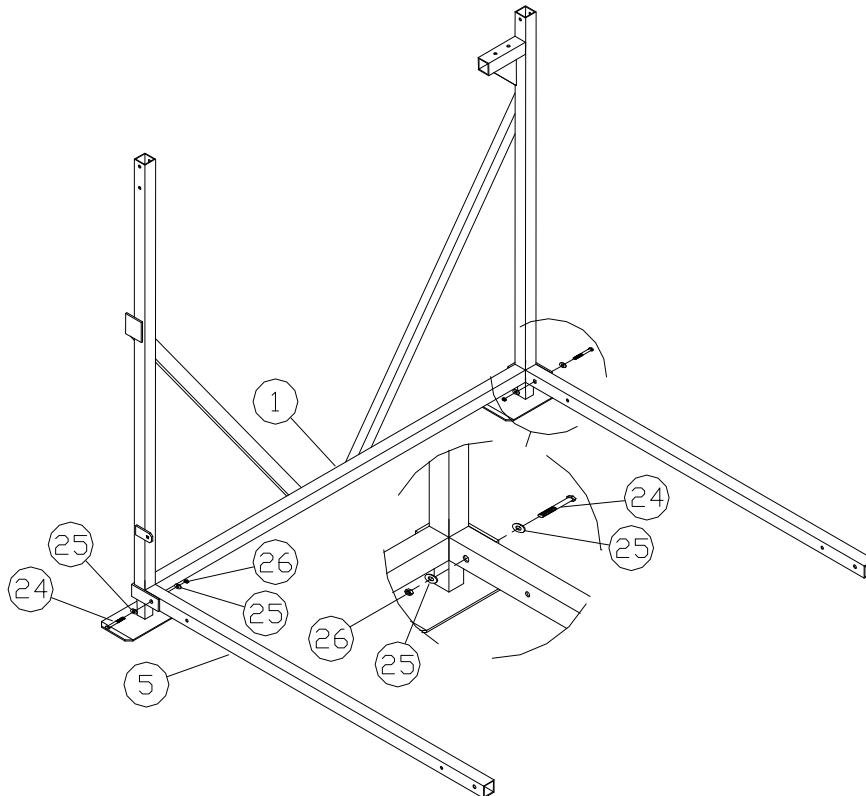

STEP 3. Locate the 2" X 3" X 68 1/8" top bed cross tubes. The tube with a single cable protruding from each end is the winch bed cross tube (**Ref. no. 6**). The other one with the two cables on each end is the anchor cross tube (**Ref. no. 7**). From the inside of the lift frame, on the winch end, place the winch bed cross tube across the end of the lift, so that the nylon slide angles are up against the inside corners of the side member upright tubes. Take the anchor cross bed tube and place across the other end of the lift frame so that the bottom loops of the cable are in the cutout holes of the bottom side tube of the side members and the nylon slide angles are against the uprights as on the other bed cross.

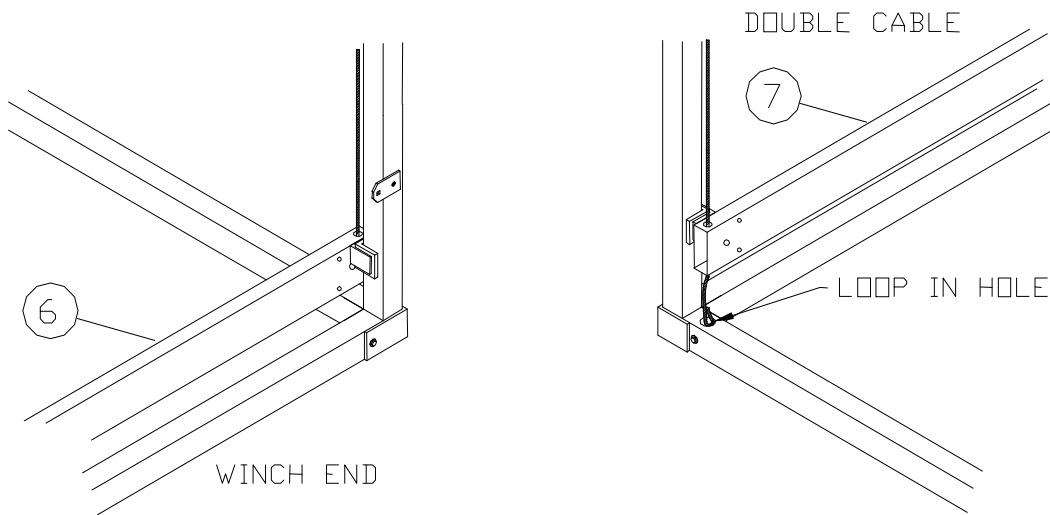

STEP 4. Assembly may be easier if 2" X 4" 's are laid diagonally on the end across the bottom four corners of the lift and the bed is assembled on top of the 2" X 4" 's. Take the two 1" X 3" X 64 1/8" side bed tube cable assembly tubes (**Ref. no. 8 & 9**). With the cable loop end down and toward the winch end of the lift, fasten the angle end of the side rail tube to the two holes in the bed cross tubes with 3/8" X 3" bolts, washers, & nuts (**Ref. no. 16, 21 & 23**). Place cable loops into the cutout holes of the bottom tube of the side members. Secure in place with 3/8" X 3" bolts, and nuts (**Ref. no. 18 & 23**). Secure the cable loops of the anchor bed cross tubes, on the other end of the lift with 3/8" X 2 1/2" stainless steel bolts and nuts. (**Ref. no. 18 & 23**). Using a tape measure, square the corners of the lift to within 1/4" or less. Tighten all bolts at this time.

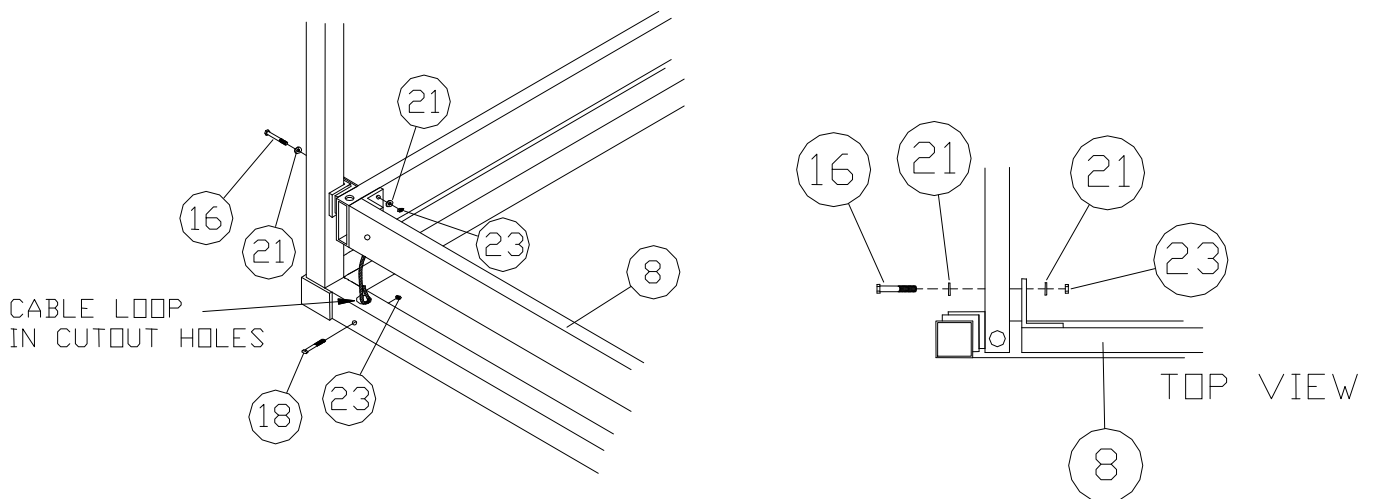

STEP 5. Bolt the winch to the inside of the winch upright with a 3/8" x 3" bolts, washers, fender washer, and nuts (Ref. no. 16, 21, 20, & 23) **NOTE: the 3/8" fender washer goes against the tube on the top hole only.** Find the end of the lift cable, thread the end of the cable through the hole in the side of the winch drum and secure with the cable clip, carriage bolt, and nut. Thread on the winch wheel (Ref. no. 10) and secure with the winch hardware.

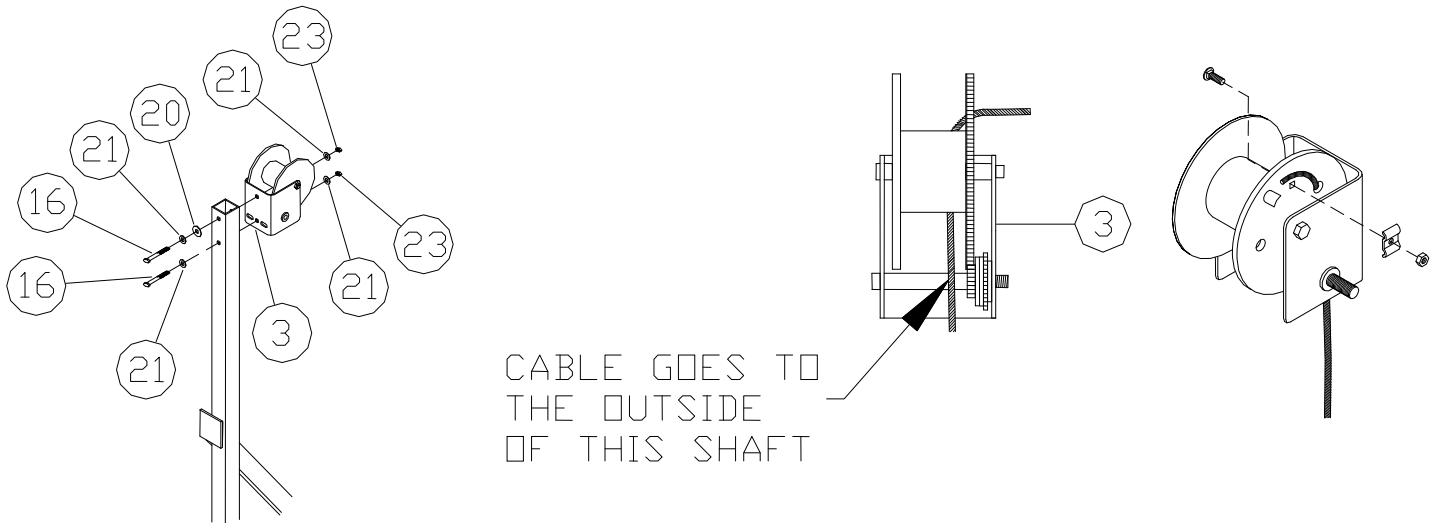

STEP 6. As a reference the corners are marked below on the assembly drawing. At corner B slide a rubber stop tube (Ref. no. 11) onto the cable. Fasten the cable stud to the top cross tube of the anchor side member using a 3/8" fender washer, 3/8" washer, and double nut with two 3/8" nuts (Ref. no. 20, 21, & 23). At corner C slide a rubber stop tube (Ref. no. 11) onto the cable that is farthest from the upright tube. Fasten both cable studs to the top cross tube of the anchor side member using a 3/8" fender washer, 3/8" washer, and double nut with two 3/8" nuts (Ref. no. 20, 21, & 23). At corner D slide a rubber stop tube (Ref. no. 11) onto the cable that is farthest from the upright tube. Fasten both cable studs to the winch side member at the horizontal stub with a 3/8" fender washer, 3/8" washer, and double nut with two 3/8" nuts (Ref. no. 20, 21 & 23). While standing on the double cable corner of the lift bed, adjust the nuts on the cable studs until the cables have the same amount of tension and the bed is just off the 2" X 4"'s. Repeat procedure on the other double cable corner; place a bolt cap (Ref. no. 27) onto each cable stud. **NOTE: To secure double nuts be sure to tighten the nuts in opposite directions against each other to lock them in position.**

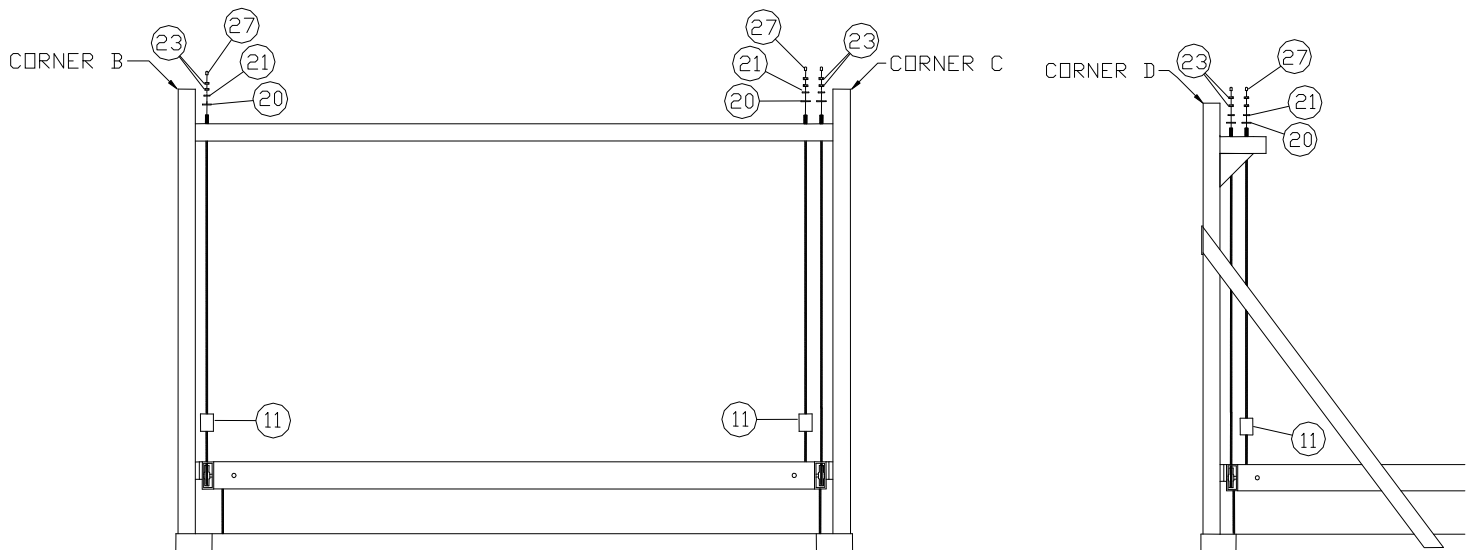

STEP 7. Find the four bunk mounting angles (1 3/4" X 1 3/4" X 9" angle with multiple holes), (**Ref. no. 12**). Bolt the angles to the bed as shown using 3/8" X 3" X 3 1/6" U-Bolts, washers, & nuts (**Ref. no. 28, 21 & 23**). Leave loose at this time.

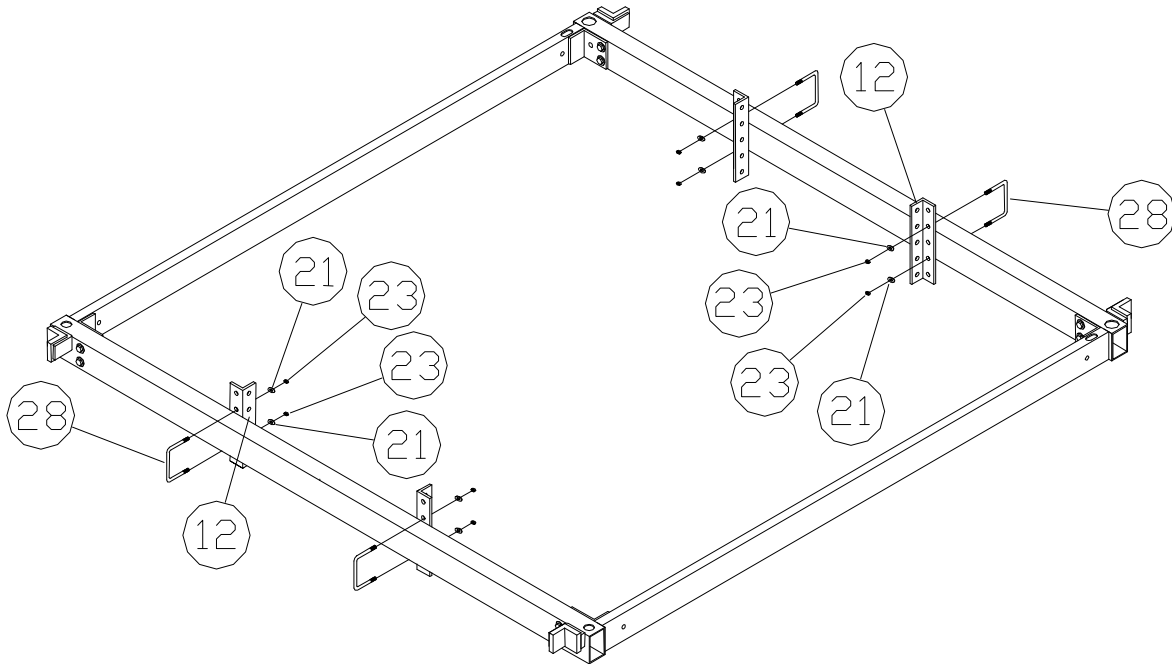

STEP 8. Set the bunk assembly (**Ref. no. 12**) on the bunk mounting angles. With the tabs on the bunk assembly to the outside of the angles. Bolt in place with 3/8" X 1 1/2" bolts, washers, and locknuts (**Ref. no. 29, 21, & 23**). Before tightening bolts, tip the bunks to the center of the bed. Adjust bunks to the desired width then tighten the nuts on the U-bolts.

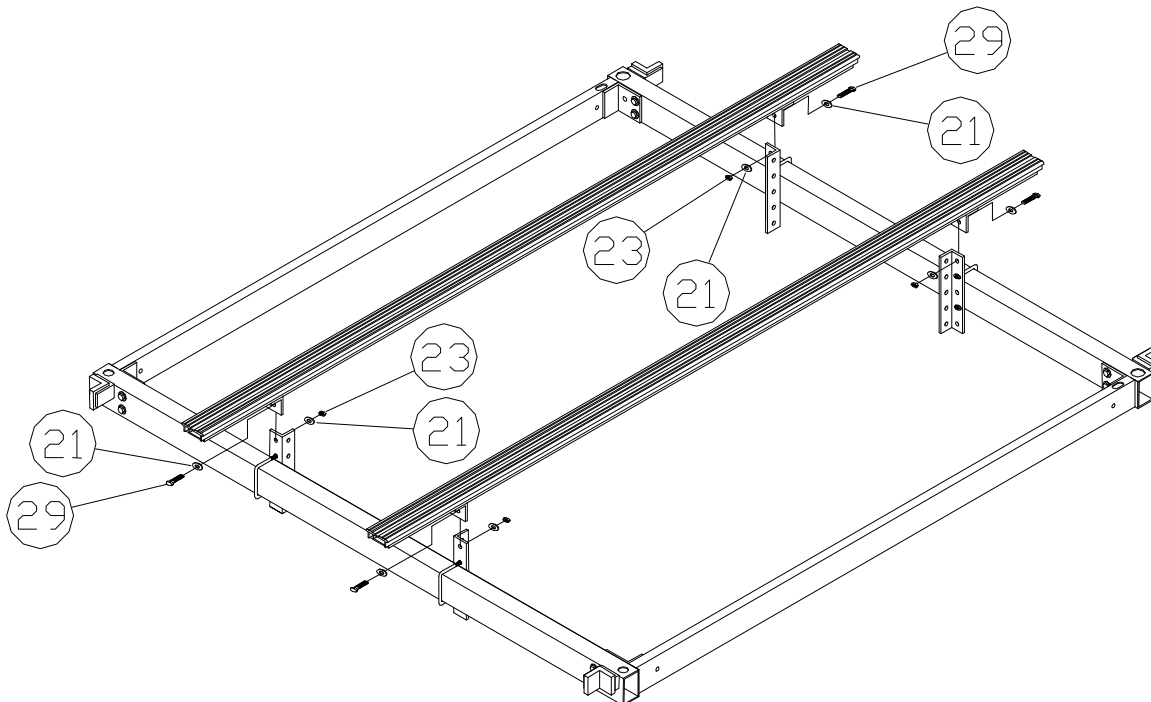

STEP 9. Bolt the four diagonal braces (**Ref. no. 14**) into the four bottom corners of the lift by placing a 3/8" X 3" bolt and washer (**Ref. no. 16 & 21**) thru the round hole of the brace and into the hole of the bottom cross tube and finger tighten with washer & nut (**Ref. no. 21 & 23**). Place a 3/8" X 1 1/2" carriage bolt (**Ref. no. 17**) thru the square hole in the tab on the upright tube and through the slotted hole of the brace, secure with 3/8" washers and nuts (**Ref. no. 21 & 23**). Tighten bottom bolts at this time. Check to see if the side upright tubes are parallel with each other. Adjust if necessary by loosening the top bolt and pushing in or pulling out on the tube. When adjusted correctly, tighten the top bolts of the braces.

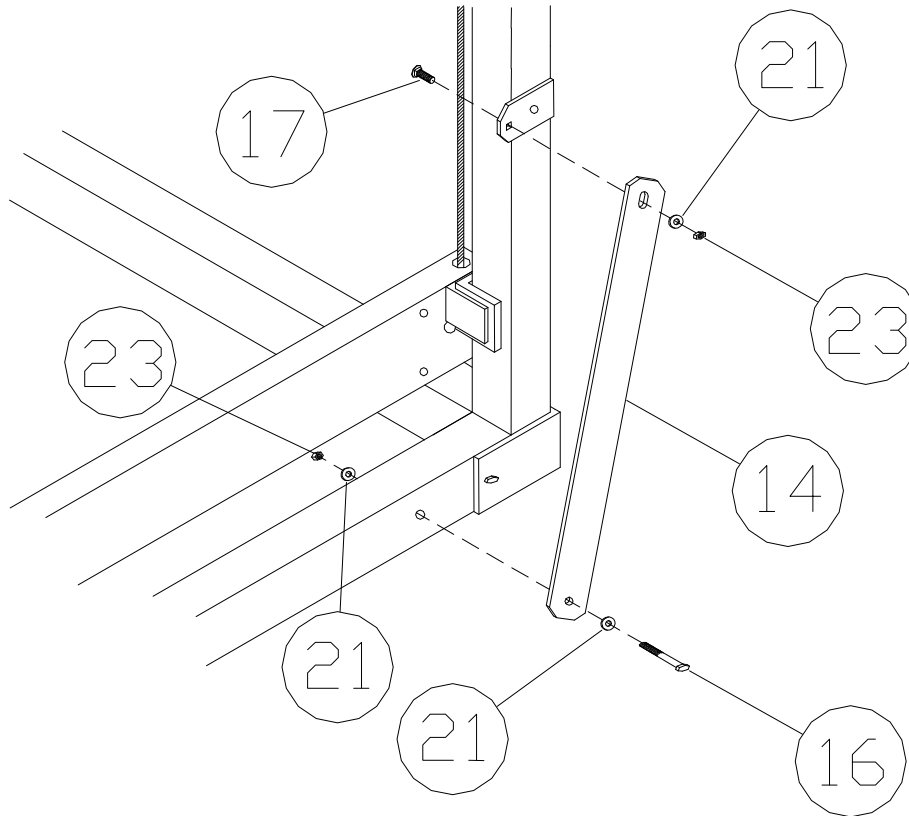

STEP 10. Place the 2" square caps onto the three uprights that don't have the winch on them and the stub with the gusset under it on the winch side. When placing lift in the lake, you must level the lift as close as possible for the lift to operate correctly. When tightening your set screws, finger tighten until tight and then tighten 2 1/2 to 3 1/2 turns after you start feeling resistance with a wrench. When raising your boat, check and see if the bed is raising evenly and that all cables have about the same tension. If the lift bed is coming up crooked, check the lift for levelness. If the lift is not level remove the boat and adjust the leveling legs to level it. Check the tension of the cables after the bed has had weight on it and been raised and lowered a few times. If there is excess slack in any of the cables tighten the nut on that cable.

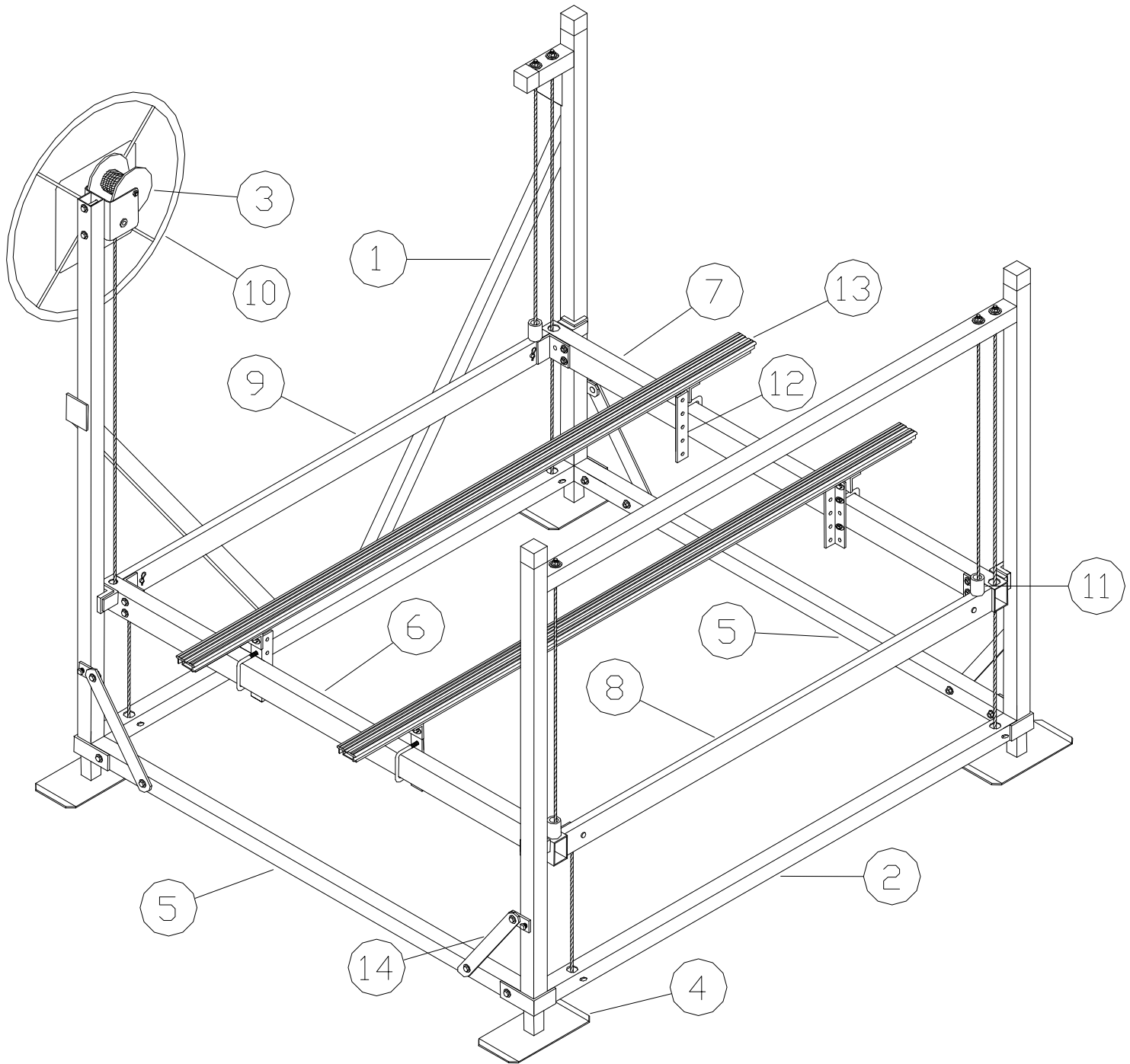

210A 1265V FLB VERTICAL LIFT CHAIN DRIVE WINCH

REF. NO.	PART NO.	DESCRIPTION	QTY
1	75F	SIDE MEMBER WINCH	1
2	74F	SIDE MEMBER ANCHOR	1
3	3180	WINCH DL 1200	1
4	62H	LEVELING LEG	4
5	20032	BOTTOM CROSS TUBE	2
6	78F	WINCH END BED CROSS TUBE	1
7	79F	ANCHOR CROSS TUBE	1
8	76F	SIDE BED TUBE RIGHT	1
9	77F	SIDE BED TUBE LEFT	1
10	23E	LIFT WHEEL	1
11	4517	RUBBER STOP 3"	3
12	60300	BUNK MOUNTING ANGLE	4
13	16F	BUNK	2
14	20030	DIAGONAL BRACE	4
15	3821	CAP 2" SQUARE GRAY	4
16	5084	3/8" X 3" BOLT	4
17	5193	3/8" X 1" CARRIAGE BOLT	4
18	5248	BOLT SS 3/8" X 2 1/2"	4
19	5170	SET SCREW 1/2" X 3/4"	4
20	5067	FENDER WASHER 3/8"	6
21	5070	WASHER 3/8"	53
22	5038	3/8 NYLOCK NUT	4
23	5056	3/8" NUT	35
24	5122	1/2" X 3" BOLT	4
25	5071	1/2" WASHER	8
26	5058	1/2" NUT	4
27	3828	3/8" BOLT CAP	5
28	5103	U-BOLT 3/8" X 3 1/16" X 3"	4
29	5155	3/8" X 1 1/2" BOLT	4

1265V TOP BED ASSEMBLY PARTS LIST

Ref. no.	Part no.	Description	Qty
1.	18F	Side Bed Tube Left 1265V	1
2.	19F	Side Bed Tube Right 1265V	1
3.	10F	Winch End Bed Cross Tube Sgl Cable 1265V	1
4.	11F	Anchor End Bed Cross Tube Dbl Cable 1265V	1
5.	3319	2 1/2" Nylon Single Pulley	10
6.	4317	Brass Spacer Bushing	4
7.	5092	Hitch Pin 1/8"	8
8.	3191	Cable SS 3/16" x 118" 1265V	2
9.	3193	Cable SS 3/16" x 123 3/4" 1265V	2
10.	3194	Cable Galv. 1/4" x 200" 1265V	1
11.	5247	Clevis Pin SS .625" x 2.5"	4
12.	4994	Machine Flat Head 1/4" x 7/8" Screw	4
13.	5053	Locknut 1/4" Keps	4
14.	20038	Plastic Slide Angle	4
15.	5243	5/8" SAE Washer	16
16.	4313	Brass Bushing .502 I.D. X .6875	4
17.	5009	Clevis Pin .50 X 1.25	4
18.	4314	Brass Bushing .502 I.D. X 1.50	4

1265V WINCH & ANCHOR BED CROSS TUBE

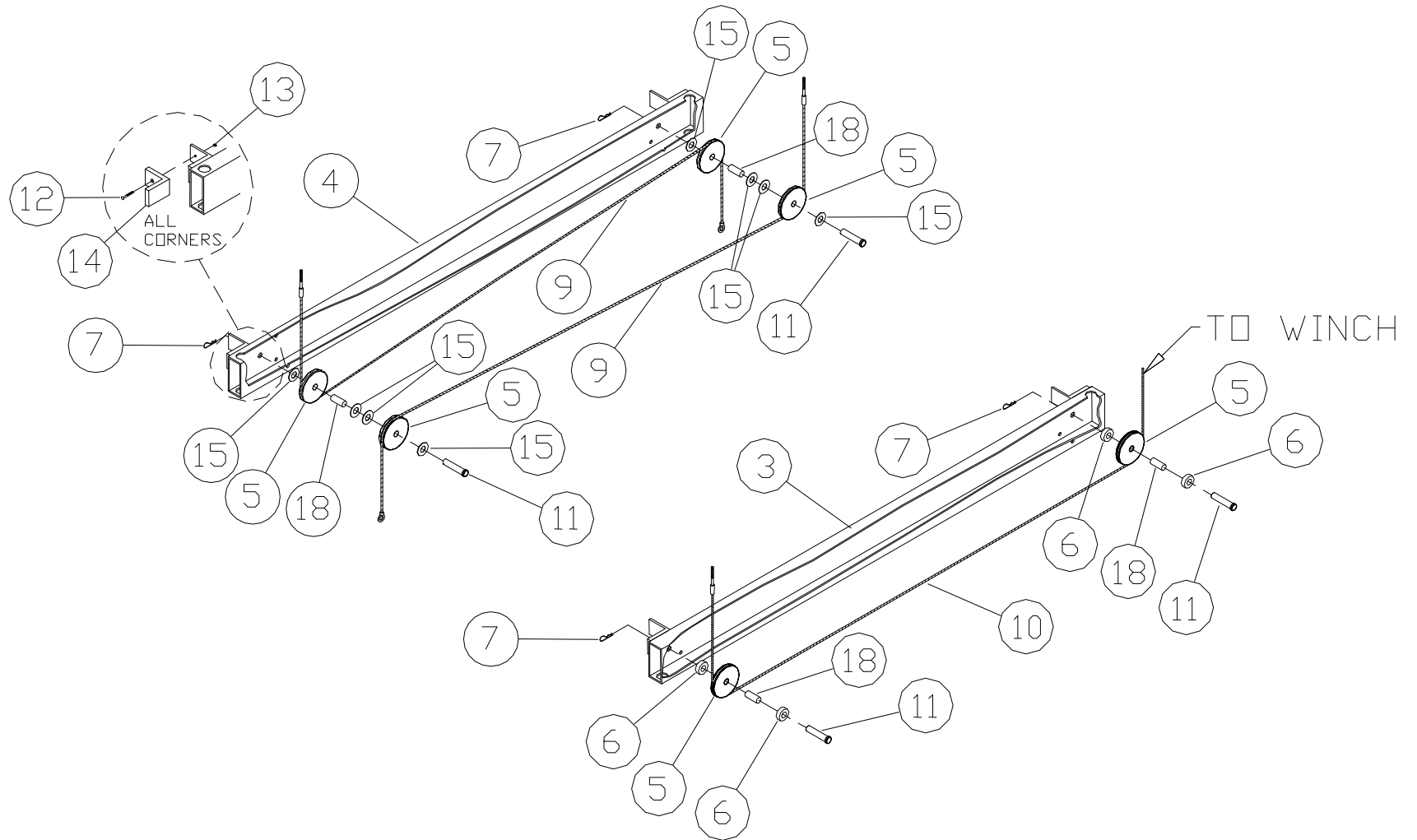

1265V SIDE BED TUBE LEFT & RIGHT

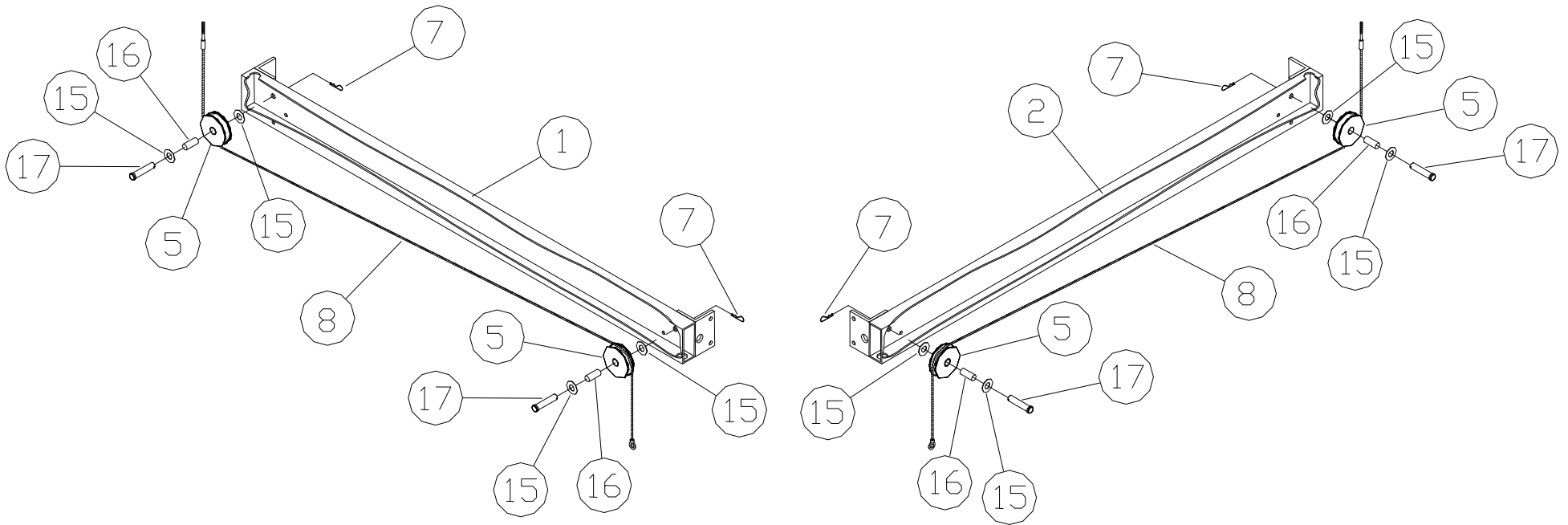



IMPORTANT BOAT LIFT SAFEGUARDS

The boat lift system must be assembled, installed and operated correctly or mechanical failure causing injury or death may occur. Be sure that all persons operating the lift are familiar with the correct operating procedures and safety guidelines.

CAUTION - Keep all body parts inside the boat when entering or exiting the boat lift. Do not try to manually guide the boat into position.

CAUTION – Keep clear of chains, cables, and all moving parts when operating the lift.

CAUTION – On lifts that have a chain drive winch, the cover must be in place while operating.

CAUTION – Never allow anyone to swim around or climb on the lift structure at any time.

CAUTION – Do not operate the lift with people inside the boat.

CAUTION – Never exceed the rated capacity of the lift as this may cause excessive damage to the lift. Do not allow people to sit in a boat that is on the lift as this may cause the lift's capacity to be exceeded. An uncovered boat can fill up with water and cause the capacity of the lift to be exceeded.

CAUTION – Before any adjustments are made to the lift, or any work is done, the boat must be removed and the bed must be fully lowered.

CAUTION – Winches are pre set from the manufacturer and do not need adjusting.

CAUTION – If using a winch with a remote control, the operator must be close enough to the lift to be sure that no one is around or on the lift, and to be sure that the lift is operating properly

CAUTION - After installation the lift must be leveled in order to operate properly. If the lift is not leveled properly there will be excessive stress on isolated areas causing failure or damage to the lift.

Before installing the lift each year inspect the cables, pulleys, and all moving parts for wear. Immediately replace any part that has excessive wear. Check the brake pad in the winch, if it is worn down to 1/16" thick, cracked, or glazed over, replace it immediately. Check all the bolts to make sure they are tight. On vertical lifts the cables may stretch and will need to be tightened so there is equal tension on all the cables.

Porta-Dock, Inc.