

PORTA-DOCK, INC.

200A FLB VERTICAL 22113V LIFT W/CHAIN DRIVE WINCH

STEP 1. Separate and group like parts and fasteners together. Locate the winch side member with the longer upright tube and diagonal braces (**Ref. no. 1**). Lay this side member on its side with the corner angles up. Locate the chain drive winch (**Ref. no. 3**). And remove the outside guard. With the winch hub down, bolt the winch to the longer upright tube of the winch side member, with 3/8" x 3 1/2" bolts, washers and nuts (**Ref. no. 23, 32, & 34**). Use the larger 3/8" fender washers (**Ref. no.31**) against the tube side. Place a square plastic cap (**Ref. no.22**) onto the stub tube.

NOTE: If installing a canopy top, place a canopy mounting bracket into the upright tube before bolting on the winch. (see canopy instructions)

If not installing a canopy, place a square plastic cap (**Ref. no. 22**) onto the top of the other upright tube. Slide the leveling legs (**Ref. no. 4**) into the side member uprights. Secure in place with 1/2" x 1" set screws (**Ref. no. 29**).

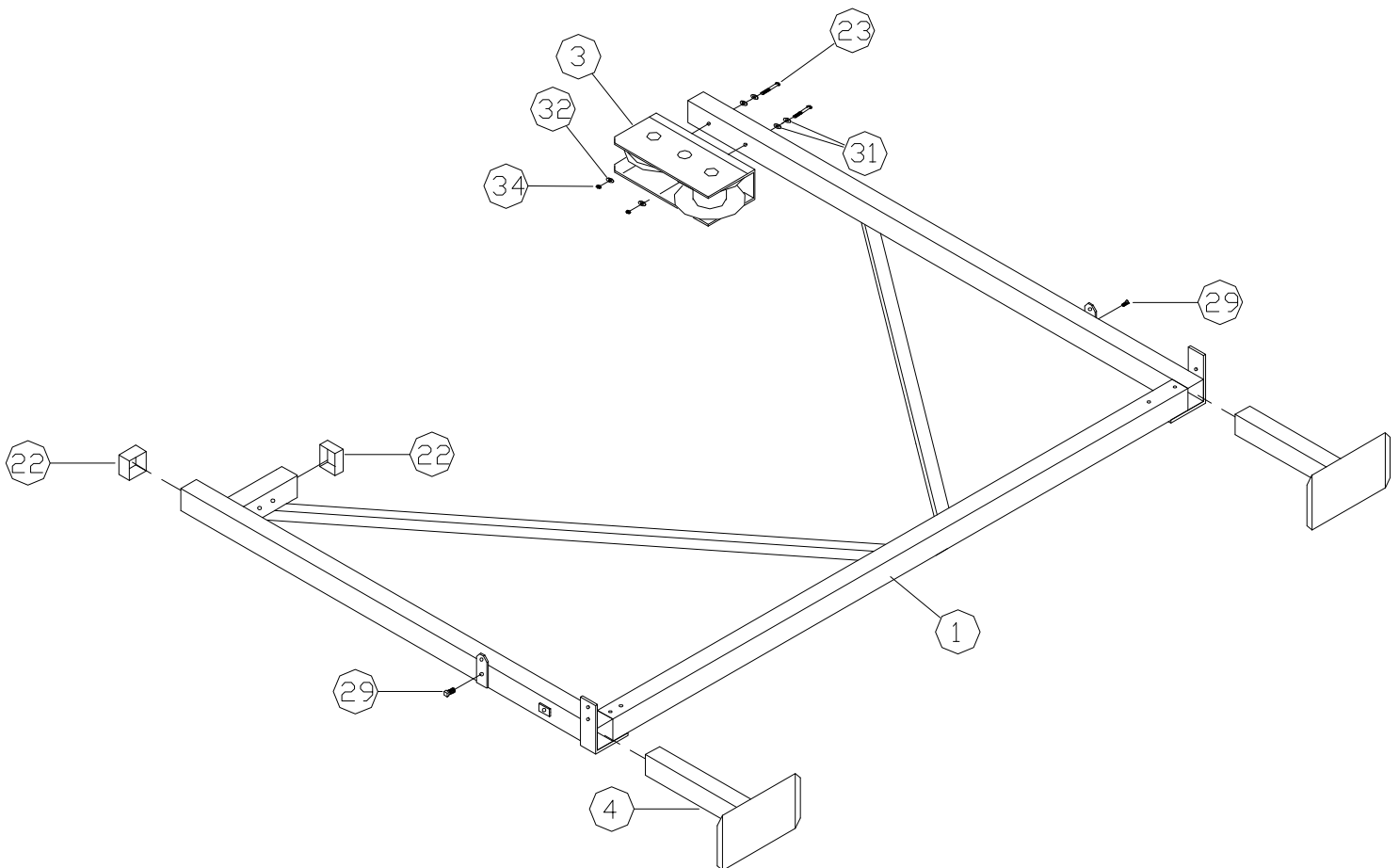

STEP 2. Locate the two 2 1/2" x 2 1/2" x 95 1/2" bottom cross tubes (**Ref. no. 5**) Using two people stand the side member up on it's leveling legs. With one person balancing the side member, bolt the bottom cross tube to the corner angles using 7/16" x 3 3/4" bolts and flange nuts. (**Ref. no.27, 38, & 33**). Leave nuts finger tight.

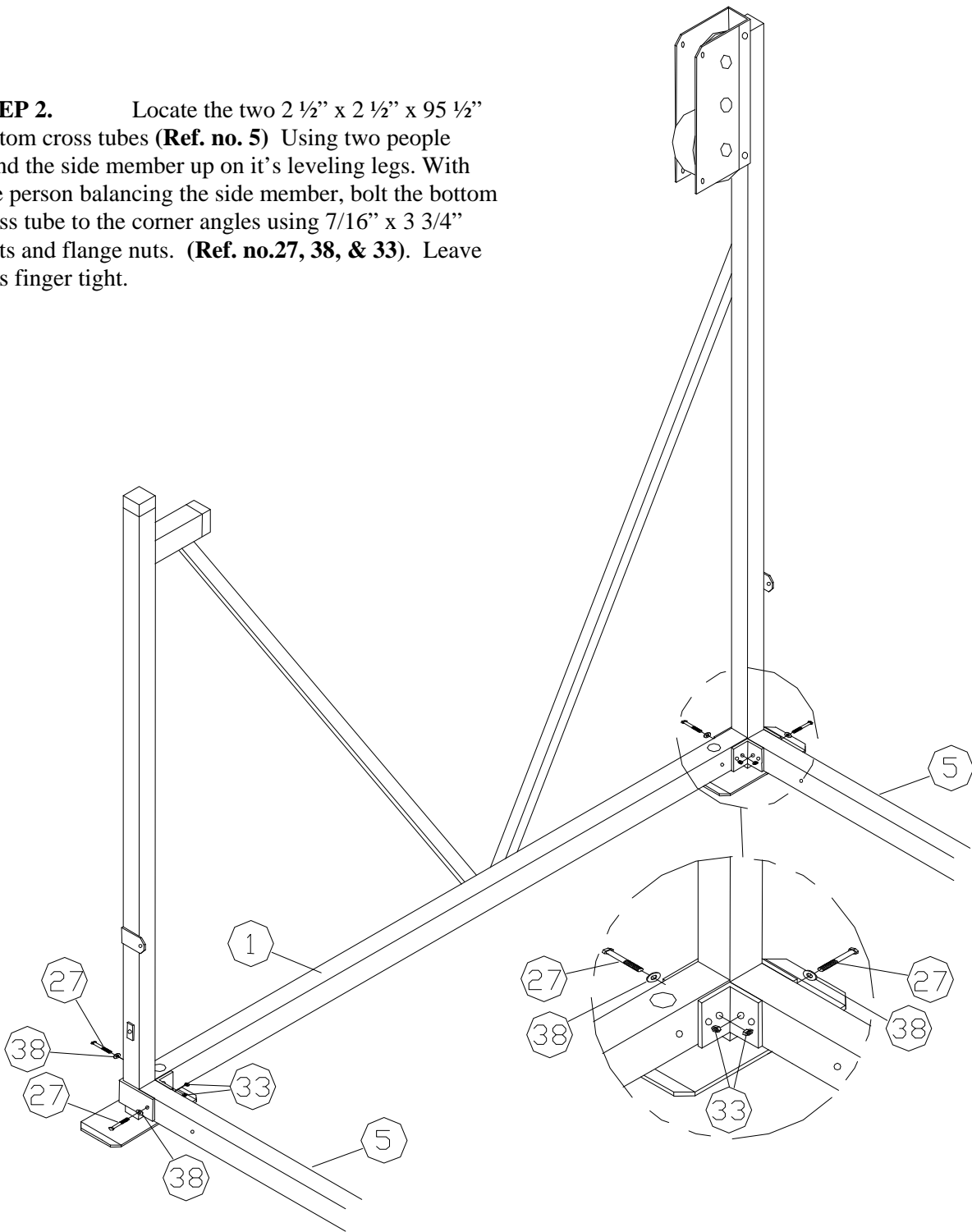

STEP 3. If not installing a canopy top, place the remaining square plastic caps onto the tops of the upright tubes on the anchor side cross member. Place leveling legs (**Ref. no. 4**) into the anchor side member and secure in place with 1/2" x 1" set screws. Bolt anchor side member up to the ends of the bottom cross tube as done with winch side member. Leave nuts finger tight.

STEP 4. Locate the 2" x 4 1/2" x 100" top bed cross tubes. The tube with a single cable protruding from each end is the winch bed cross tube. (**Ref. no. 6**). The other one with the two cables on each end is the anchor cross tube (**Ref. no. 7**). From the inside of the lift frame, on the winch end, place the winch bed cross tube across the end of the lift, so that the nylon slide angles are up against the inside corners of the side member upright tubes. Take the anchor cross bed tube and place across the other end of the lift frame so that the bottom loops of the cable are in the cutout holes of the bottom side tube of the side members and the nylon slide angles are against the uprights as on the other bed cross

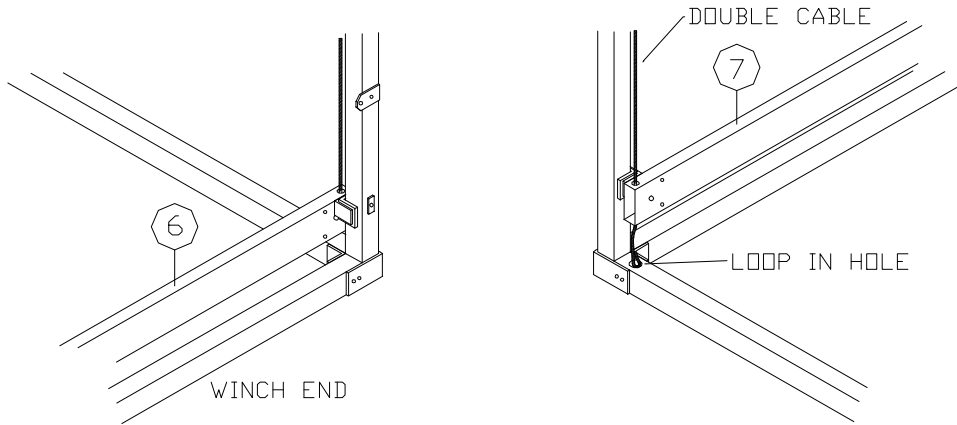

STEP 5. Assembly may be easier if 2" x 4" 's are laid diagonally on the end across the bottom four corners of the lift and the bed is assembled on top of the 2" x 4" 's. Take the two 2" x 4 1/2" x 104" side bed tube cable assembly tubes (**Ref. no. 8 & 9**). With the cable loop end down and toward the winch end of the lift, fasten the angle end of the side rail tube to the two holes in the bed cross tubes with 3/8" x 3" bolts, washers & nuts (**Ref. no.24, 32 & 34**). Place cable loops into the cutout holes of the bottom tube of the side members. Secure in place with 7/16" x 3" stainless bolts, and flange nuts. (**Ref. no. 28 & 33**) Secure the cable loops of the anchor bed cross tubes, on the other end of the lift with 7/16" x 3 1/2" stainless bolts and flange nuts. (**Ref. no. 26 & 33**). Using a tape measure, square the corners of the lift to within 1/4" or less. Tighten all bolts at this time.

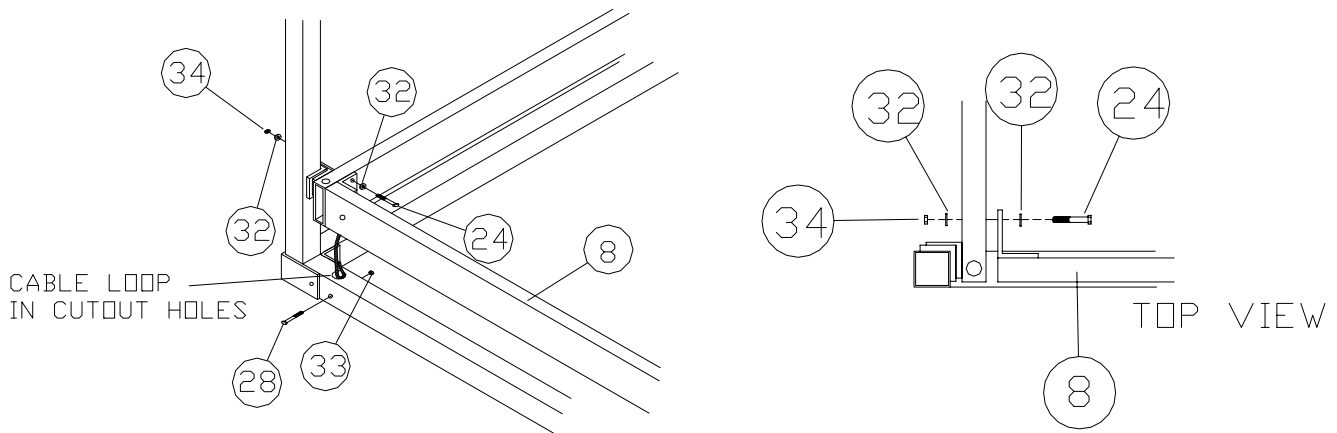

STEP 6. Take the winch nut, washer, (**Ref.no. 17 & 19**) and plastic shipping collar off the winch shaft; if possible lubricate the winch shaft with a light lubricant. Thread on winch wheel (**Ref.no. 10**) and replace washer and nut. Tighten winch acorn nut onto the winch shaft. There will be roughly 1/8" clearance between the winch washer and the winch wheel. Turn the wheel clockwise until the set screw that is in the face of the drum is toward the front edge of the winch. Loosen the allen head set screw in the face of the drum. Place the cable into the hole in the face of the drum, making sure that the cable goes into the sleeve inside the drum. Tighten the set screw.

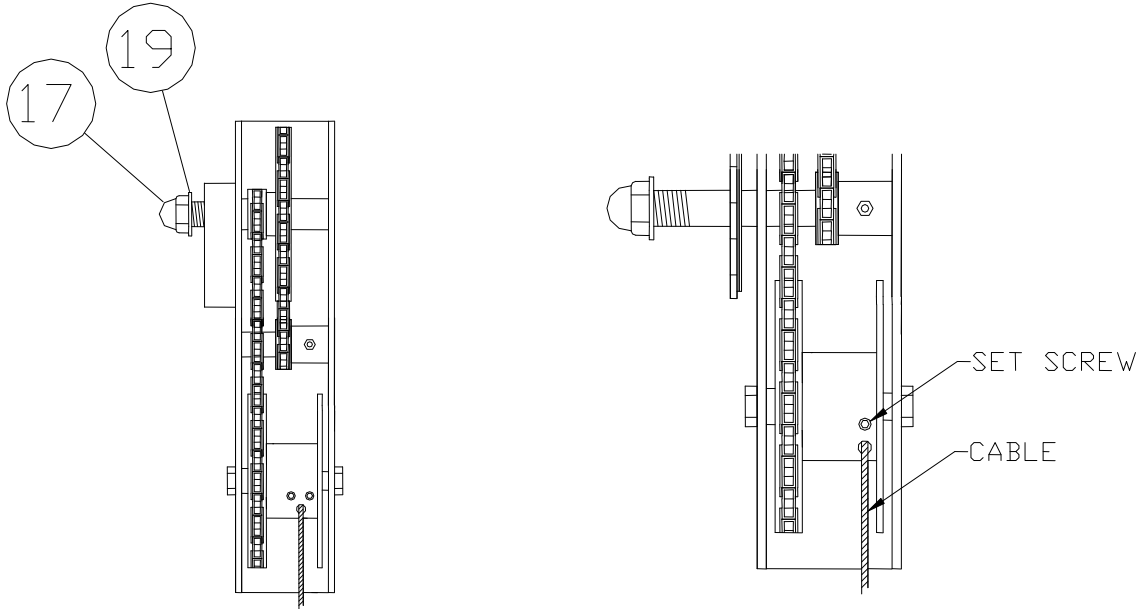

STEP 7. As a reference the corners are marked below on the assembly drawing. At corner B slide a rubber stop tube (**Ref.no.11**) onto the cable. Fasten the cable stud to the top cross tube of the anchor side member using the 1/4" x 2" x 2" cable support plate, 3/8" washer, and 3/8" galvanized nut (**Ref.no.16, 32 & 35**). At corner C slide a rubber stop tube onto the cable that is closest to the upright tube. Fasten both cable studs to the top cross tube of the anchor side member using the 1/4" x 2" x 5 1/2" cable support plate, 3/8" washers, and 3/8" galvanized nuts (**Ref.no.15, 32 & 35**). At corner D slide a rubber stop tube onto the cable that is closest to the upright tube. Fasten both cable studs to the winch side member at the horizontal stub with 3/8" washers and 3/8" galvanized nuts (**Ref.no.32 & 35**). While standing on the double cable corner of the lift bed, adjust the nuts on the cable studs until the cables have the same amount of tension and the bed is just off the 2" x 4"s. Repeat procedure on the other double cable corner.

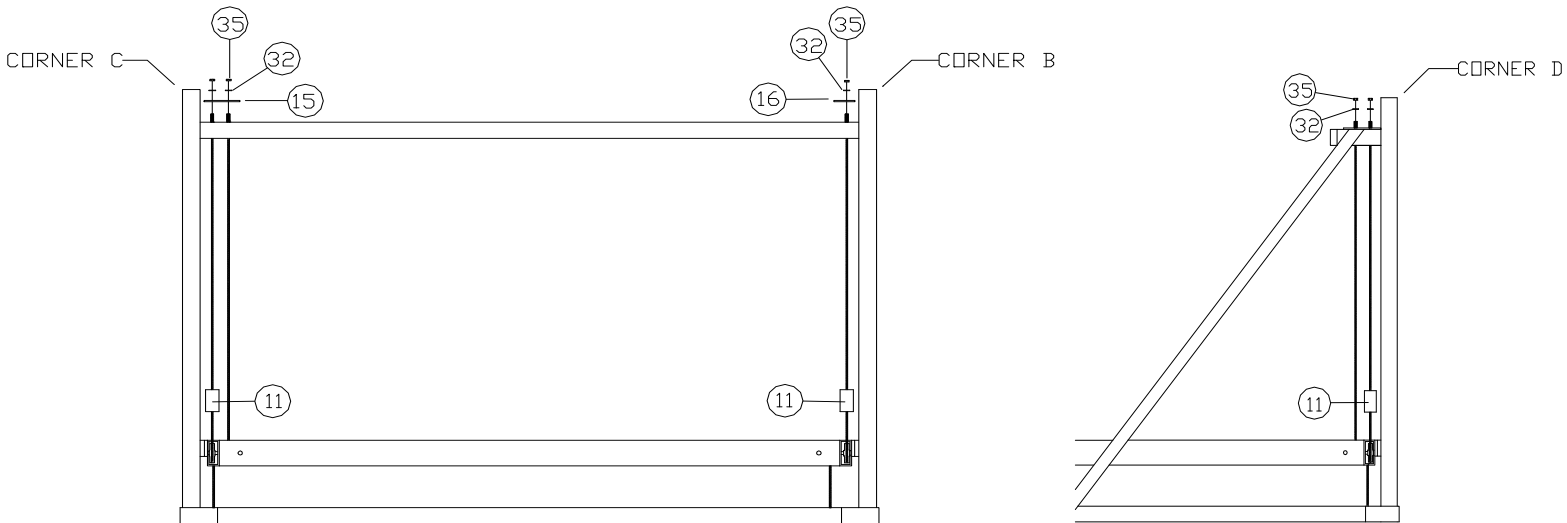

STEP 8. Bolt the four diagonal braces (**Ref.no.21**) into the four bottom corners of the lift by placing a 3/8" x 3 1/2" bolt and washer (**Ref.no.23 & 32**) thru the round hole of the brace and into the hole of the bottom cross tube and finger tighten with washer & nut (**Ref.no.32 & 34**). Place a 3/8" x 1 1/4" bolt and washer (**Ref. no. 25 & 32**) thru the slotted hole of the brace and into the tab of the upright tube. Tighten bottom bolts at this time. Check to see if the side upright tubes are parallel with each other. Adjust if necessary by pushing in or pulling out on the tube. When adjusted correctly, tighten the top bolts of braces.

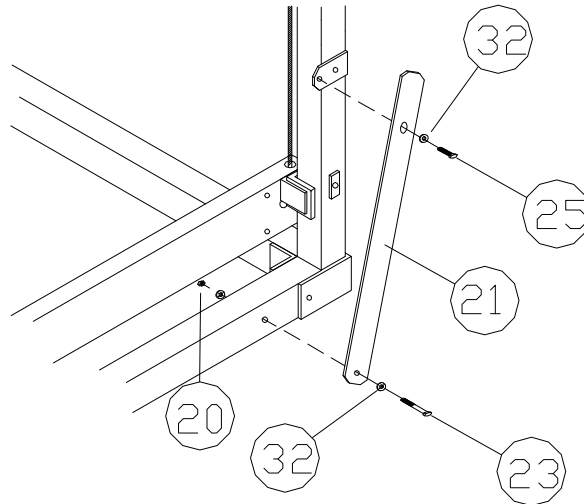

STEP 9. When placing lift in the lake, you must level the lift as close as possible for the lift to operate correctly. When tightening your set screws, finger tighten until tight and then tighten 2 1/2 to 3 1/2 turns after you start feeling resistance with a wrench. When raising your boat, check and see if the bed is raising evenly and that all cables have about the same tension. If the lift bed is coming up crooked, check the lift for levelness. If lift is not level remove boat and adjust cable nuts to level bed.

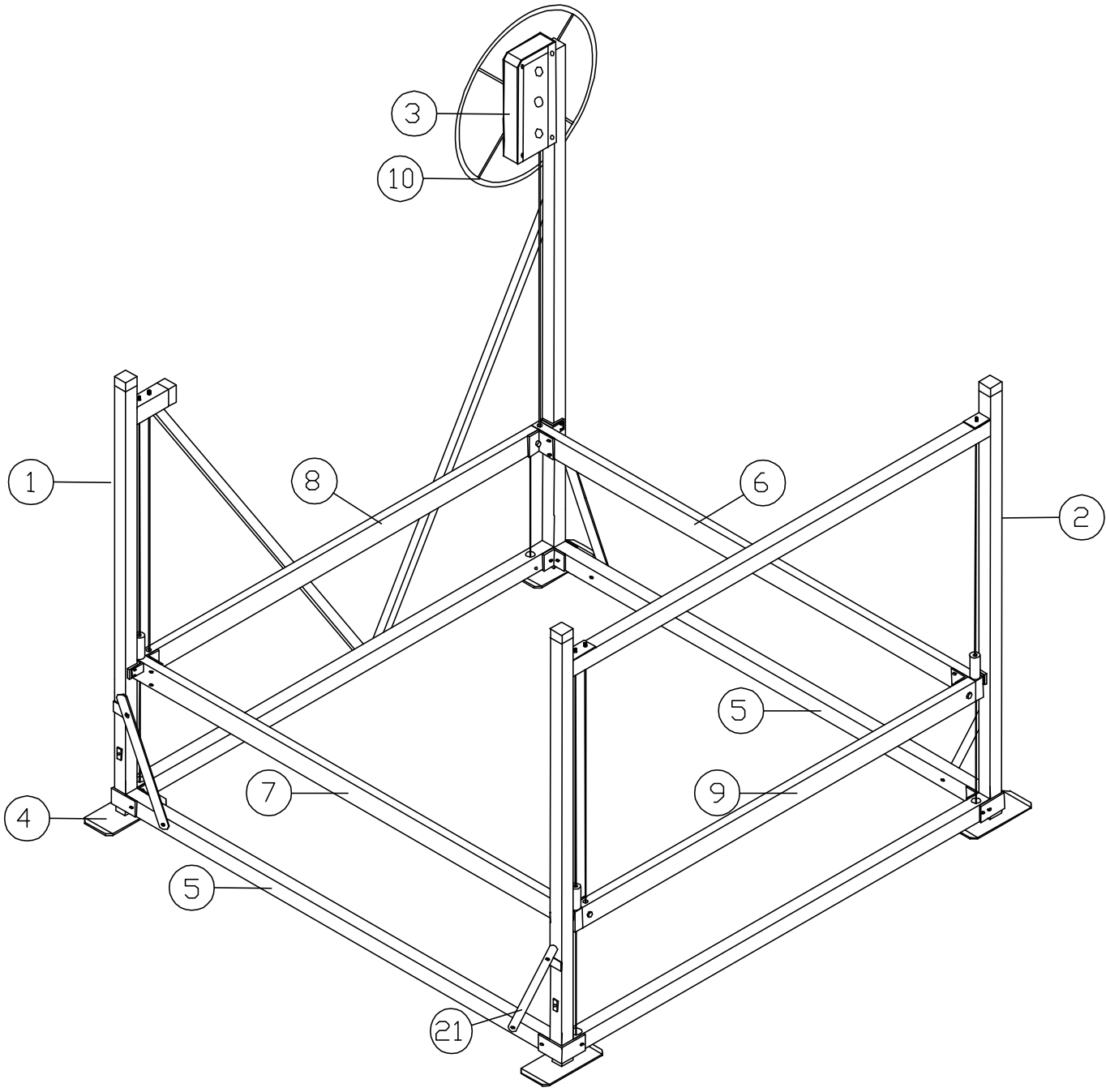

200A 20113V FLB VERTICAL LIFT CHAIN DRIVE WINCH

REF. NO.	PART NO.	DESCRIPTION	QTY
1	21F	SIDE MEMBER WINCH	1
2	22F	SIDE MEMBER ANCHOR	1
3	3026	WINCH CHAIN DRIVE 11-1	1
4	61H	LEVELING LEG	4
5	52Q	BOTTOM CROSS TUBE	2
6	86Q	WINCH END BED CROSS TUBE	1
7	87Q	ANCHOR CROSS TUBE	1
8	41K	SIDE BED TUBE RIGHT	1
9	40K	SIDE BED TUBE LEFT	1
10	45F	LIFT WHEEL	1
11	4517	RUBBER STOP 3"	3
15	20025	2 HOLE CABLE SUPPORT PLATE	1
16	20024	SINGLE HOLE SUPPORT PLATE	1
17	3027	WINCH NUT	1
19	5072	WINCH NUT WASHER 5/8"	1
20	3109	WINCH CABLE GALVANIZED 1/4" X 170"	1
21	20018	DIAGONAL BRACE	4
22	3822	CAP 2 1/2" SQUARE GRAY	4
23	5085	3/8" X 3 1/2" BOLT	6
24	5084	3/8" X 3" BOLT	8
25	5091	3/8" X 1 1/4" BOLT	4
26	5148	BOLT SS 7/16" X 3 1/2"	2
27	5242	BOLT 7/16" X 3 3/4"	8
28	5228	BOLT SS 7/16" X 3"	2
29	5174	SET SCREW 1/2" X 1"	4
31	5067	FENDER WASHER 3/8"	4
32	5070	WASHER 3/8"	51
33	5158	7/16" FLANGE NUT	12
34	5056	3/8" NUT	23
35	5230	3/8 GALVANIZED NUT	5
38	5069	7/16" WASHER	8

CHAIN WINCH MOUNTING INSTRUCTIONS

STEP 1. Because of the hole placement on the winch, it may be easier to remove the back mounting channel (Ref. No. 2) and bolt it to the inside of the lifts upright first and then re-bolt the winch assembly (Ref. No. 4) to the back mounting channel.

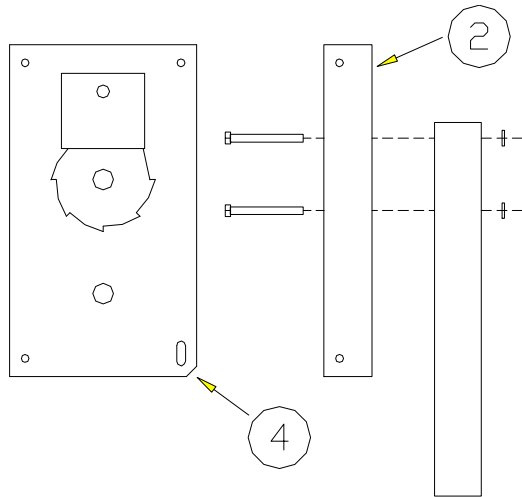

22113V TOP BED ASSEMBLY PARTS LIST

<u>Ref. no.</u>	<u>Part no.</u>	<u>Description</u>	<u>Qty</u>
1.	50G	Side Bed Tube Left 20113V	1
2.	51G	Side Bed Tube Right 20113V	1
3.	22L	Winch End Bed Cross Tube Sgl Cable 20113V	1
4.	23L	Anchor End Bed Cross Tube Dbl Cable 20113V	1
5.	3316	4" Nylon Single Pulley	6
6.	3317	4" Nylon Double Pulley	2
7.	5092	Hitch Pin 1/8"	8
8.	3042	Cable SS 1/4" x 177" 2000V	2
9.	3041	Cable SS 1/4" x 191 1/2" 2000V	2
10.	3114	Cable GALV 5/16" x 290" 2000V	1
11.	5045	Clevis Pin SS .625" x 2.5"	8
12.	3827	Cap 2" x 4.7" End Cap Vertical Upright	4
13.	4994	Machine Flat Head 1/4" x 7/8" Screw	4
14.	5053	Locknut 1/4" Keps	4
15.	20017	Plastic Slide Angle	4

20113V WINCH & ANCHOR BED CROSS TUBE

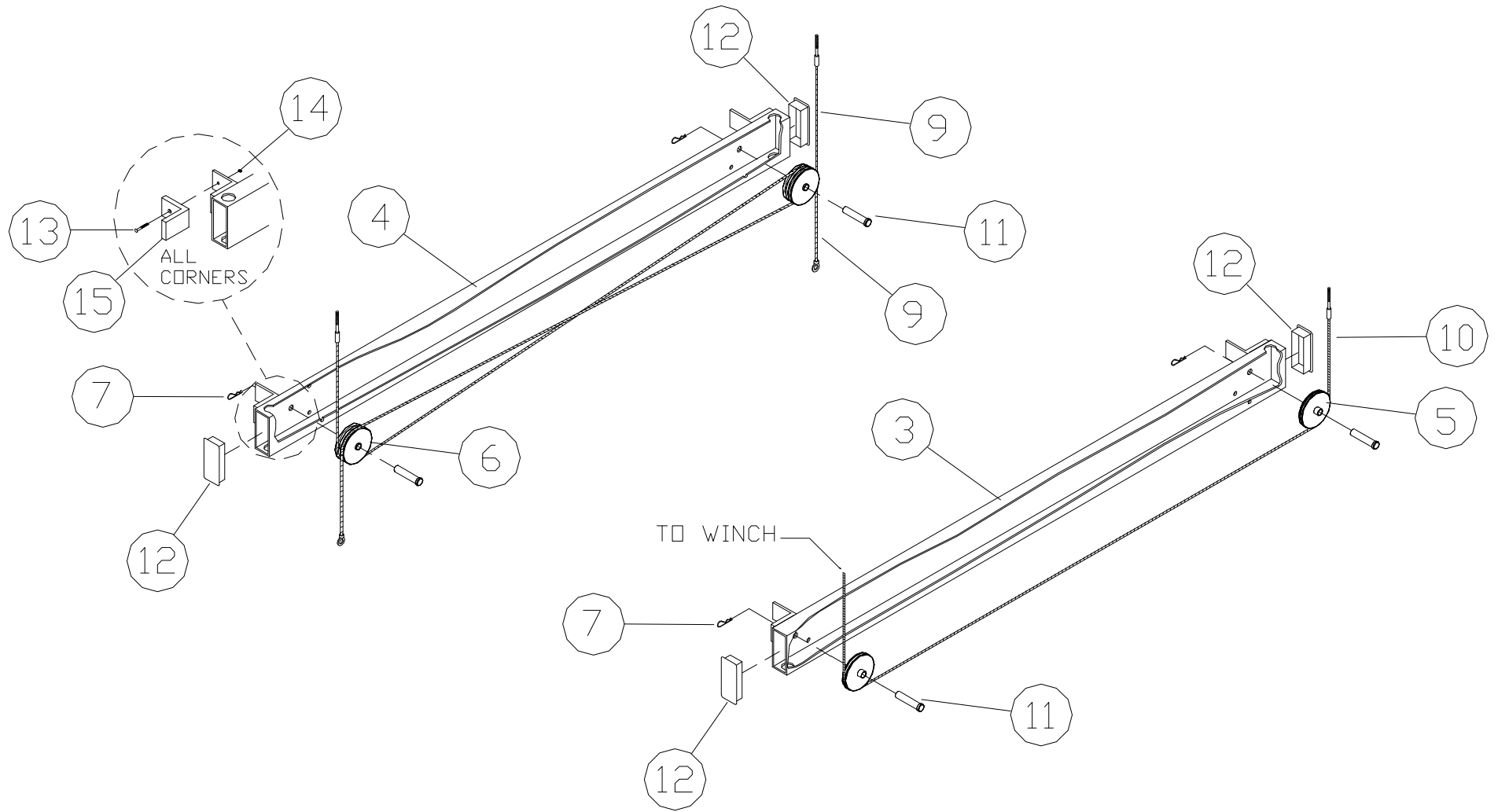

20113V SIDE BED TUBE LEFT & RIGHT

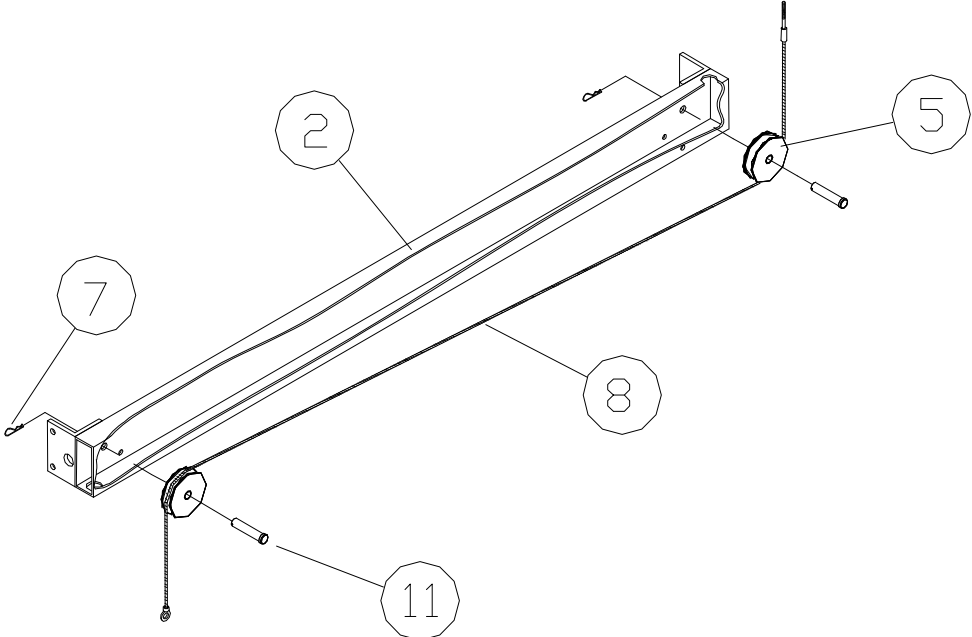
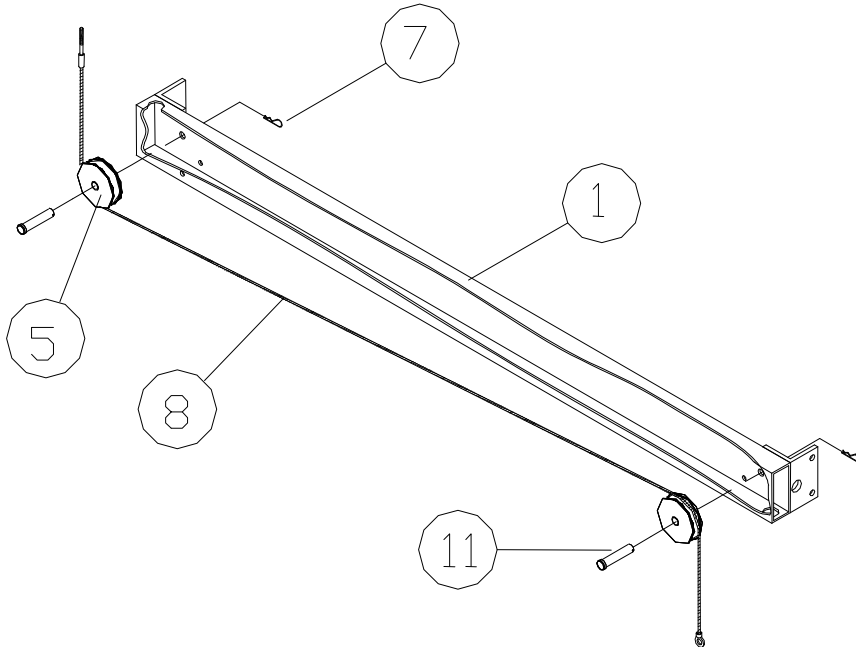



IMPORTANT BOAT LIFT SAFEGUARDS

The boat lift system must be assembled, installed and operated correctly or mechanical failure causing injury or death may occur. Be sure that all persons operating the lift are familiar with the correct operating procedures and safety guidelines.

CAUTION - Keep all body parts inside the boat when entering or exiting the boat lift. Do not try to manually guide the boat into position.

CAUTION – Keep clear of chains, cables, and all moving parts when operating the lift.

CAUTION – On lifts that have a chain drive winch, the cover must be in place while operating.

CAUTION – Never allow anyone to swim around or climb on the lift structure at any time.

CAUTION – Do not operate the lift with people inside the boat.

CAUTION – Never exceed the rated capacity of the lift as this may cause excessive damage to the lift. Do not allow people to sit in a boat that is on the lift as this may cause the lift's capacity to be exceeded. An uncovered boat can fill up with water and cause the capacity of the lift to be exceeded.

CAUTION – Before any adjustments are made to the lift, or any work is done, the boat must be removed and the bed must be fully lowered.

CAUTION – Winches are pre set from the manufacturer and do not need adjusting.

CAUTION – If using a winch with a remote control, the operator must be close enough to the lift to be sure that no one is around or on the lift, and to be sure that the lift is operating properly.

CAUTION - After installation the lift must be leveled in order to operate properly. If the lift is not leveled properly there will be excessive stress on isolated areas causing failure or damage to the lift.

Before installing the lift each year inspect the cables, pulleys, and all moving parts for wear. Immediately replace any part that has excessive wear. Check the brake pad in the winch, if it is worn down to 1/16" thick, cracked, or glazed over, replace it immediately. Check all the bolts to make sure they are tight. On vertical lifts the cables may stretch and will need to be tightened so there is equal tension on all the cables.

