

155A 2500 LB. Gear Drive Winch **ALUMINUM NARROW PONTOON LIFT**

Thank you for purchasing a PORTA-DOCK product.
Please read these instructions and follow them step by step.

STEP 1. Locate the four adjustable legs (**REF. # 1**) and slide them into the ends of the side members (**REF. # 3 & 4**). Now set the side members about 4' apart, making sure the three flat tabs on the bottom rail of the side members are facing inward.

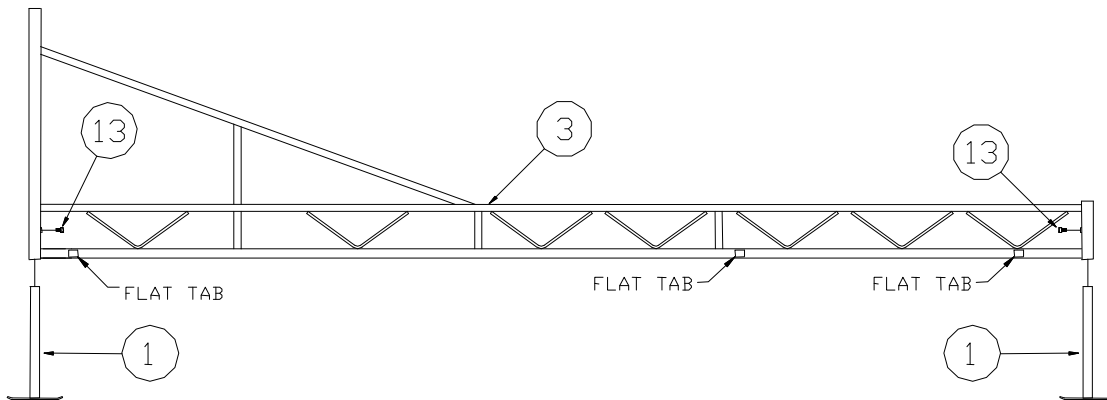

STEP 2 Find the three bottom cross bars (**REF. # 5**). With the channels facing to the rear of the lift, set them between the side members so that the end plate is up against the end of the tabs that are welded on the bottom side tube. Fasten to the bottom tube of the side member with 3/8" X 2 1/16" X 2 3/4" U-Bolts and 3/8" flange nuts (**REF. # 14 & 18**).

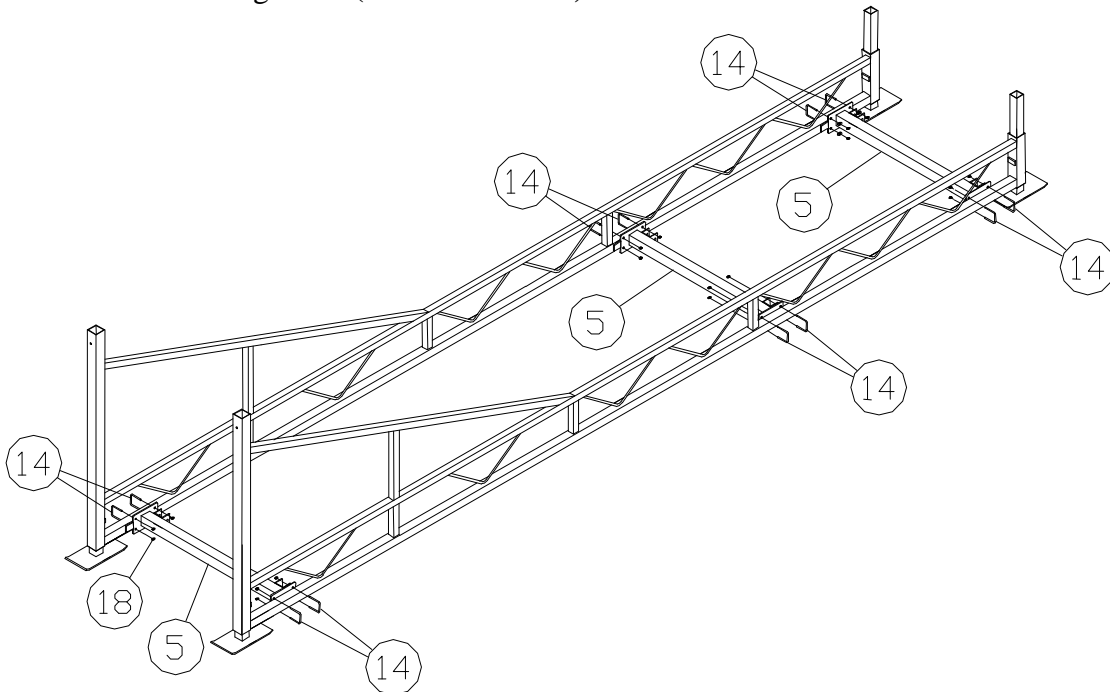

STEP 3. Locate the lifting arms (REF. # 2).

NOTE: THE CROSSBARS ON THE LIFTING ARMS HAVE TO BE TO THE TOP

Slide a brass pivot bushing (REF. # 24) into each pivot cap on the bottom ends of the lifting arms.

Mount the lifting arms to the bottom cross bar pivot channel using 1/2" X 3" clevis pins, 1/2" washers and 1/8" X 1" cotter pin (REF.# 22, 25 & 23). Make sure both legs of the cotter pin are bent in opposite directions.

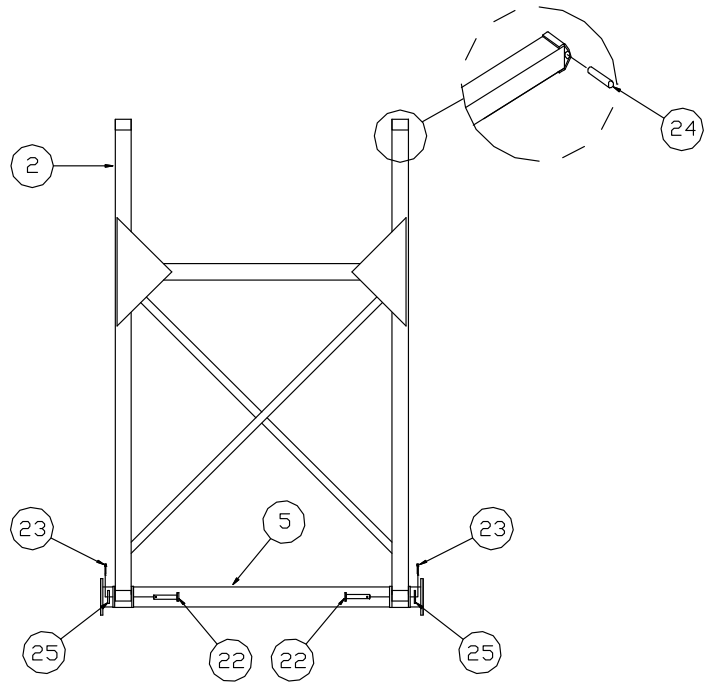

STEP 4. Slide a brass pivot bushing (REF. # 24) into the top pivot caps on the lifting arms. Mount the two rail tubes (REF. # 6 & 7) with the angles to the front and the face to the outside. Fasten with a 1/2" X 3" clevis pin, 1/2" washer and 1/8" X 1" cotter pin (REF. # 22, 25 & 23). Bolt on the rail support tube (REF. # 9) between the angles on the bunk tubes with 3/8" X 2 1/2" bolts, 3/8" washers and 3/8" nuts (REF. # 28, 15 & 16).

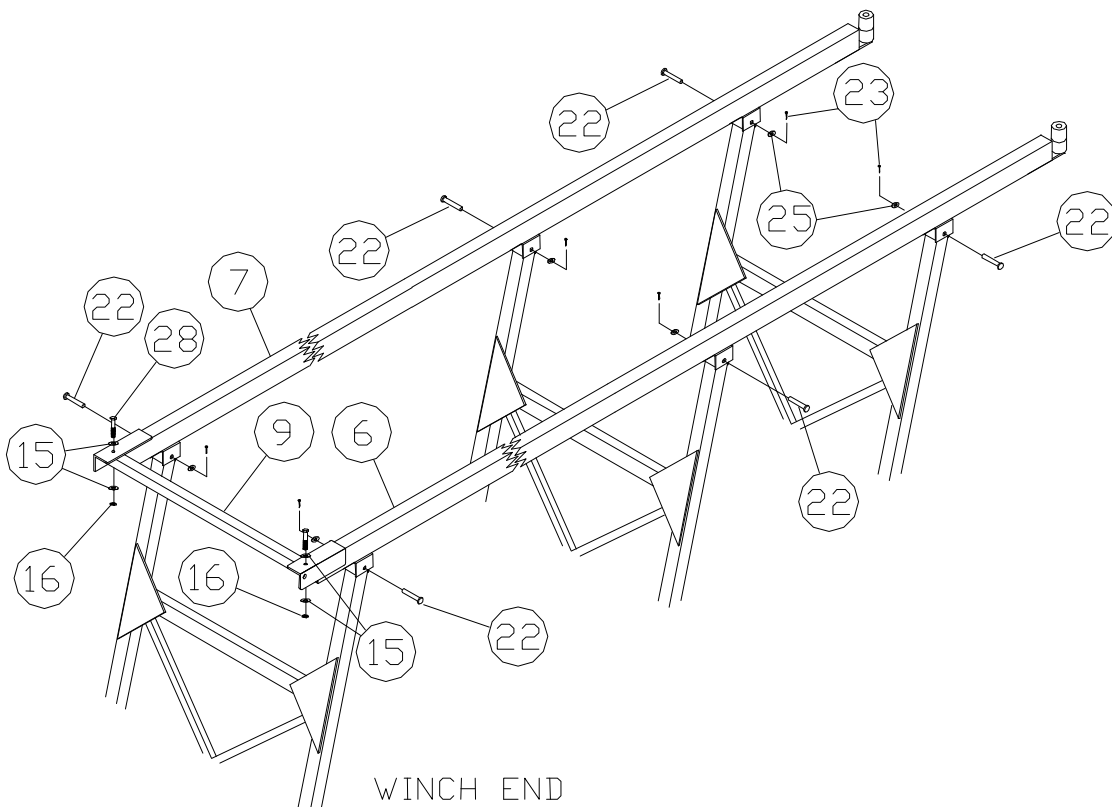

STEP 5a. Find the winch stand bar (**REF.# 10**). Turn the winch stand bar so that the two short tubes are down and the longer winch upright tube is to the side where the winch will be installed. Mount the winch (**REF. # 11**) to the winch stand bar using 3/8" X 4" bolts, 3/8" washers, 3/8" fender washers and 3/8" nuts (**REF. # 26, 15, 17, & 16**). Bolt the winch stand bar to the lift by placing the two short tubes of the winch stand bar over the ends of the front upright tubes of the side members. Secure in place with 3/8" X 3 1/2" bolts, 3/8" washers, and 3/8" nuts (**REF. # 27, 15, & 16**). Locate the stop tube (**REF. #8**) and bolt it to the underside of the diagonal brace of the side member using 3/8" X 4" bolts, 3/8" washers, and 3/8" nut (**REF. # 26, 15, & 16**).

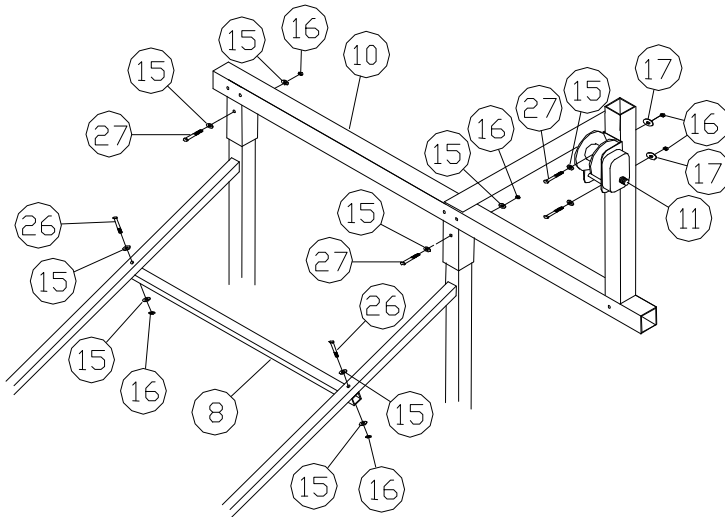

STEP 5b. Find the 7/16" X 4 1/2" bolt (**REF.# 37**) slide on the two 7/16" washers (**REF.# 38**), then the 3 link pulley (**REF. # 19**) then five 7/16" washers (**REF. # 38**). Bolt this assembly to the winch stand bar below the winch. Secure with a 7/16" washer (**REF. # 38**) and 7/16" nut (**REF. # 39**). Locate the cable thimble (**REF. # 36**) and slide it onto a 3/8" X 4 5/8" round u-bolt (**REF. # 30**). Bolt the u-bolt to the winch stand bar below the diagonal brace as shown, using a support plate, 3/8" washers, and 3/8" lock nuts (**REF. # 32, 15 & 21**).

Slide a two link pulley (**REF. # 20**) onto a 3/8" X 4 5/8" round u-bolt (**REF. # 30**). Bolt the u-bolt to the end of the winch stand bar using a support plate, 3/8" washers and 3/8" lock nuts (**REF. # 32, 15 & 21**). Leaving nuts loose enough so the pulley and chain can still pivot

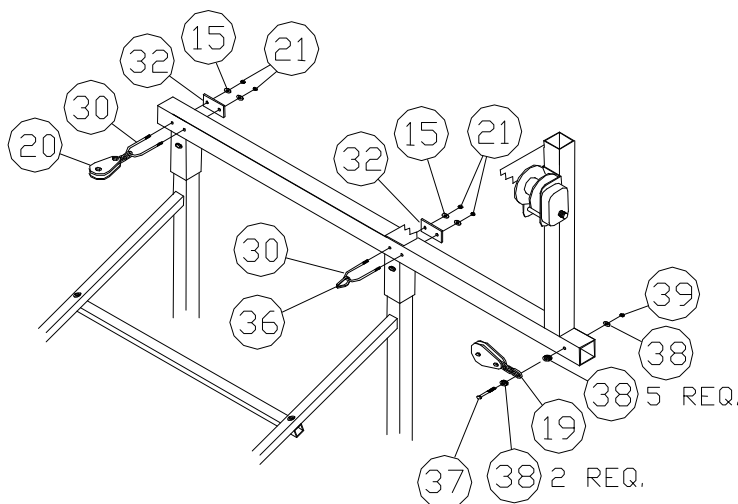

STEP 6. Find the last two 2 link pulleys (**REF. # 20**). Bolt them to the inside of the rail tube angles as shown with 3/8" X 1 1/2" bolts, 3/8" washers and 3/8" locknuts (**REF. # 29, 15 & 21**). Leave nuts just loose enough so the pulley assembly can pivot. Locate the cable (**REF. # 33**) from the outside of the winch.

1. Pass the cable through the hole on the side of the winch drum.
2. Pass the cable through the pulley below the winch.
3. Run the cable across and through the pulley on the far side of the winch stand bar.
4. Then to the pulley on the nearest rail tube
5. Then across to the pulley on the other lifting rail.
6. Run it to and around the cable thimble that is u-bolted to the winch stand bar

Make sure this cable is below the cable that runs parallel with the winch stand bar. Secure in place with a 1/4" cable clamp (**REF. # 34**). Make sure the u-bolt of the cable clamp is on the dead end of the cable. Place a 3" X 3" plastic cap (**REF. # 31**) onto each end of the winch stand bar. Place a 2" X 2" plastic cap (**REF. # 35**) onto each rear leveling leg.

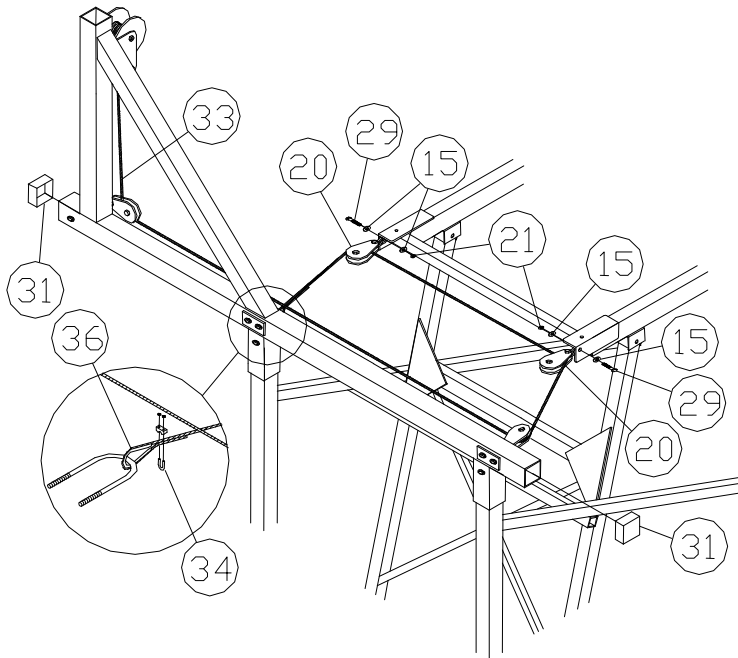

STEP 7. Spin lift wheel (**REF. # 12**) onto the winch shaft. Secure in place with hardware, see winch instruction book. After the lift has been used several times, recheck all set screws and bolts. Retighten in necessary.

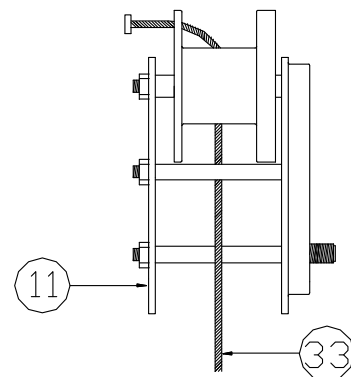

PARTS LIST
155A 2500 LB. Gear Drive Winch
ALUMINUM NARROW PONTOON LIFT

REF#	PART#	DESCRIPTION	QTY
1	61H	Leveling Legs	4
2	76Q	Lifting Arm	3
3	72Q	Side Member Left	1
4	73Q	Side Member Right	1
5	79Q	Bottom Cross Bar	3
6	81Q	Rail Tube W/Rollers Right	1
7	82Q	Rail Tube W/Rollers Left	1
8	50281	Stop Tube	1
9	50282	Rail Support Tube	1
10	80Q	Winch Stand Bar	1
11	3003	Winch DL2503 W/Hdwe	1
12	51E	Lift Wheel DL	1
13	5174	Set Screw 1/2" X 1"	4
14	5046	U-Bolt Sq. 3/8" X 2 1/16" X 2 3/4"	12
15	5070	Washer 3/8"	22
16	5056	Nut 3/8"	8
17	5067	Fender Washer 3/8"	2
18	5156	Flange Nut 3/8"	24
19	E69	2 1/2" Pulley & 3 Link Chain	1
20	E75	2 1/2" Pulley & 2 Link Chain	3
21	5038	Lock nut 3/8"	6
22	5097	Clevis Pin 1/2" X 3"	12
23	5025	Cotter Pin 1/8" X 1"	12
24	3313	Brass Pivot Bushing	12
25	5071	Washer 1/2"	12
26	5089	Bolt 3/8" X 4"	2
27	5085	Bolt 3/8" X 3 1/2"	4
28	5083	Bolt 3/8" X 2 1/2"	2
29	5088	Bolt 3/8" X 1 1/2"	2
30	5049	U-Bolt Round 3/8" X 4 5/8"	2
31	3823	Plastic Cap 3" X 3"	2
32	50286	U BOLT Support Plate	2
33	3054	Cable 1/4" X 26'	1
34	5004	Cable Clamp 1/4"	1
35	3821	Plastic Cap 2" X 2"	2
36	5044	Cable Thimble	1
37	5241	Bolt 7/16" X 4 1/2"	1
38	5069	Washer 7/16"	8
39	5057	Nut 7/16"	1

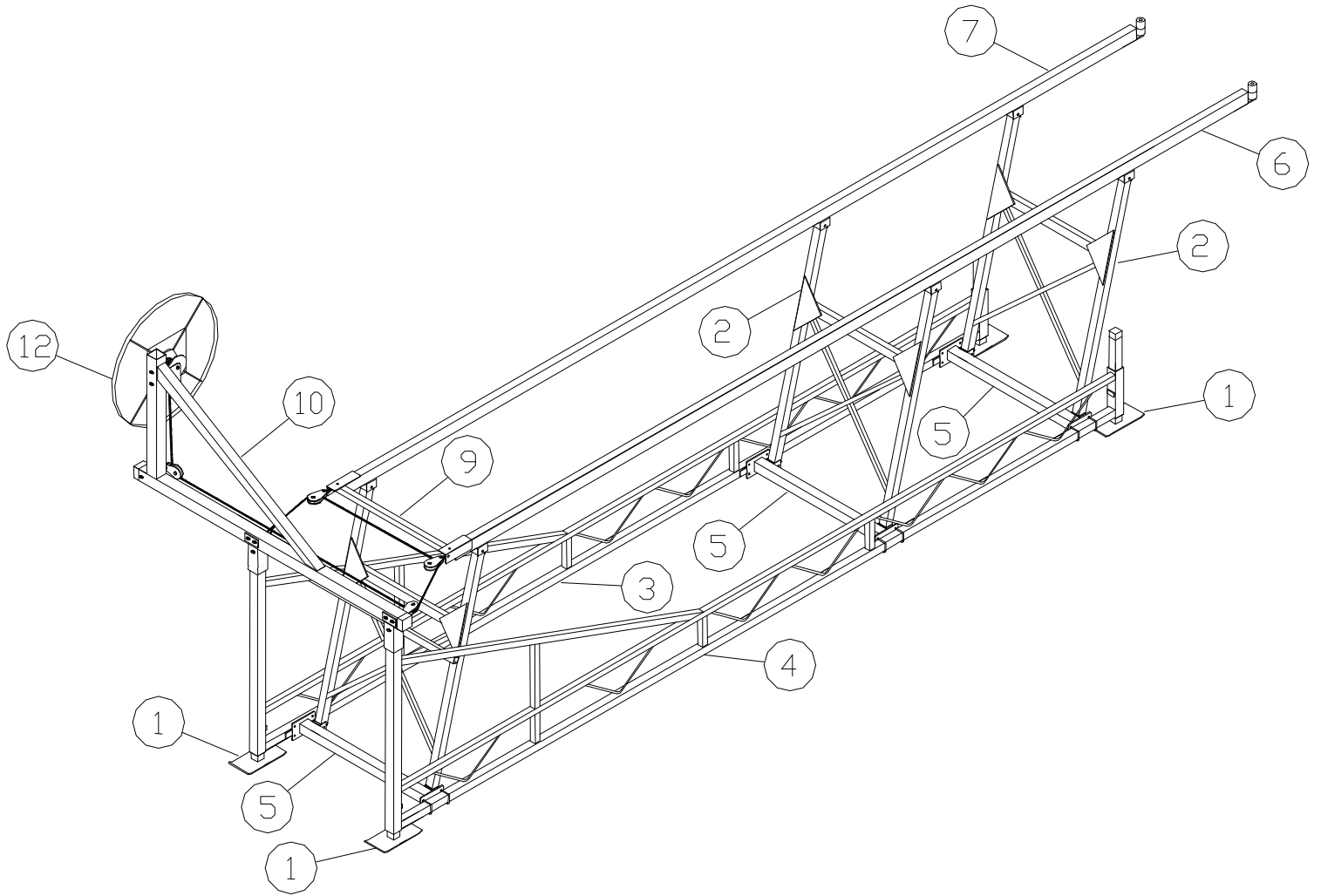



IMPORTANT BOAT LIFT SAFEGUARDS

The boat lift system must be assembled, installed and operated correctly or mechanical failure causing injury or death may occur. Be sure that all persons operating the lift are familiar with the correct operating procedures and safety guidelines.

CAUTION - Keep all body parts inside the boat when entering or exiting the boat lift. Do not try to manually guide the boat into position.

CAUTION – Keep clear of chains, cables, and all moving parts when operating the lift.

CAUTION – On lifts that have a chain drive winch, the cover must be in place while operating.

CAUTION – Never allow anyone to swim around or climb on the lift structure at any time.

CAUTION – Do not operate the lift with people inside the boat.

CAUTION – Never exceed the rated capacity of the lift as this may cause excessive damage to the lift. Do not allow people to sit in a boat that is on the lift as this may cause to lifts capacity to be exceeded. An uncovered boat can fill up with water and cause the capacity of the lift to be exceeded.

CAUTION – Before any adjustments are made to the lift, or any work is done, the boat must be removed and the bed must be fully lowered.

CAUTION – Winches are pre set from the manufacturer and do not need adjusting.

CAUTION – If using a winch with a remote control, the operator must be close enough to the lift to be sure that no one is around or on the lift, and to be sure that the lift is operating properly

CAUTION - After installation the lift must be leveled in order to operate properly. If the lift is not leveled properly there will be excessive stress on isolated areas causing failure or damage to the lift.

Before installing the lift each year inspect the cables, pulleys, and all moving parts for wear. Immediately replace any part that has excessive wear. Check the brake pad in the winch, if it is worn down to 1/16” thick, cracked, or glazed over, replace it immediately. Check all the bolts to make sure they are tight. On vertical lifts the cables may stretch and will need to be tightened so there is equal tension on all the cables.

Porta-Dock, Inc.