

PORTA-DOCK, INC.

100A 1200 LB. 84" WIDE ALUMINUM CANTILEVER BOAT LIFT
102A 1200 LB. 113" WIDE ALUMINUM CANTILEVER BOAT LIFT

Thank you for purchasing our product!
Please read these instructions and follow them step by step. *

STEP 1. Separate and group like parts and fasteners together. Locate the four leveling legs with pads (**REF. # 1**) and the two side members (**REF. # 2 & 3**) slide the four leveling legs into the end upright tubes of the side members. Secure in place with 1/2" x 1" set screws (**REF. # 37**) Set the side members approximately 84" apart for 84" wide lifts and 113" apart for 113" wide lifts. Make sure the rear gusset plate is to the outside and the small flat tabs on the bottom side tube are to the inside.

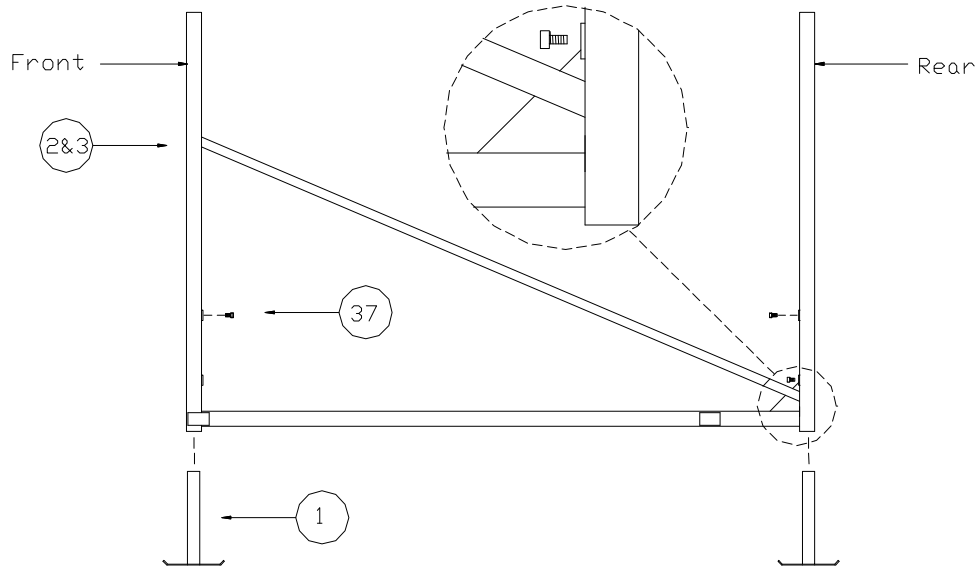

STEP 2. Find the two bottom cross bar tubes (**REF. # 4**) (They're the ones with the end plates and channels welded on.) With the channel facing to the rear of the lift set them between the two side members so that the end plate is up against the end of the tabs that are welded on the bottom side tube. Fasten to bottom tube with the eight square U bolts and flange nuts. (**REF. # 16 & 17**) Finger tighten nuts. Using a tape measure, square the four corners of the uprights so that it is within about a 1/4" Tighten all U-bolt nuts.

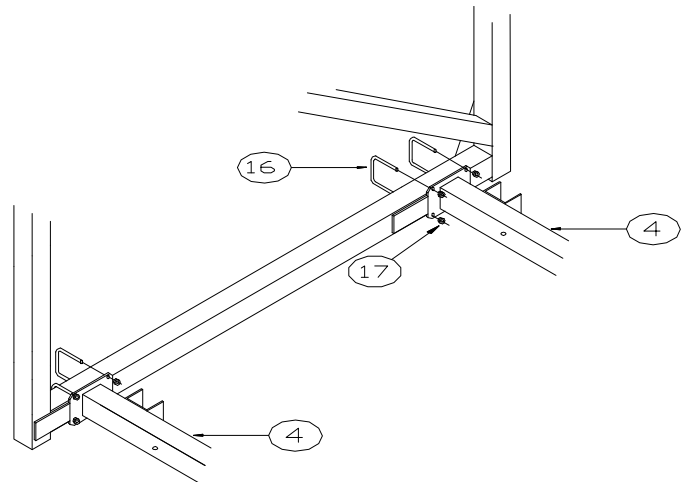

STEP 3. Locate the two H shape lifting arms (**REF. # 5**). Slide a Brass pivot bushing (**REF. # 18**) into each pivot cap on the ends of the lifting arms. Place the lifting arm into the channels of the bottom cross tubes and fasten into place using and 1/2" x 3" clevis pins and 1/2" washers (**REF. # 19 & 20**). Secure with pins. (**REF. # 21**).

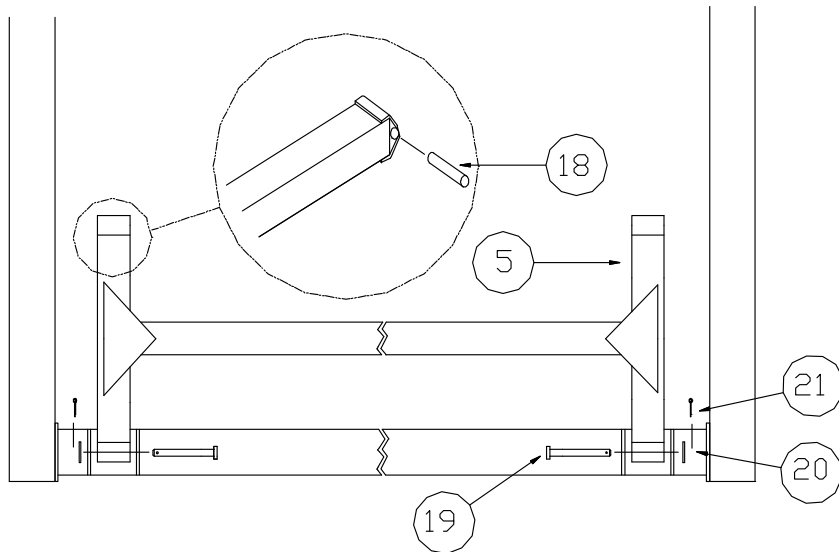

STEP 4. Find the lifts top bed member (rec. frame 81" x 86 3/4" (**REF. # 6**)). Set the bed member pivot channels into the ends of the lifting arms. The pivot channels on the outside of the bed are toward the front of the lift. Locate the two front pulley brackets, 1/2" x 6 1/2" clevis pins and 1/2" washers (**REF. # 13, 22 & 20**). On the front corner of the bed, place a pulley bracket with the pulley sheave toward the outside, in between the corner angle and the pivot channel. From the corner angle side, slide a 1/2" x 6 1/2" clevis pin through the angle and the pulley bracket into two 1/2" washers and through the lifting arm and pivot channel. Place another 1/2" washer over the clevis pin and secure with cotter pin. (See illustration after **STEP 5**)

STEP 5. Fasten the rear lifting arms to the back pivot channels of the member with 1/2" x 3" clevis pins, 1/2" washers and cotter pins (**REF. # 19, 20 & 21**).

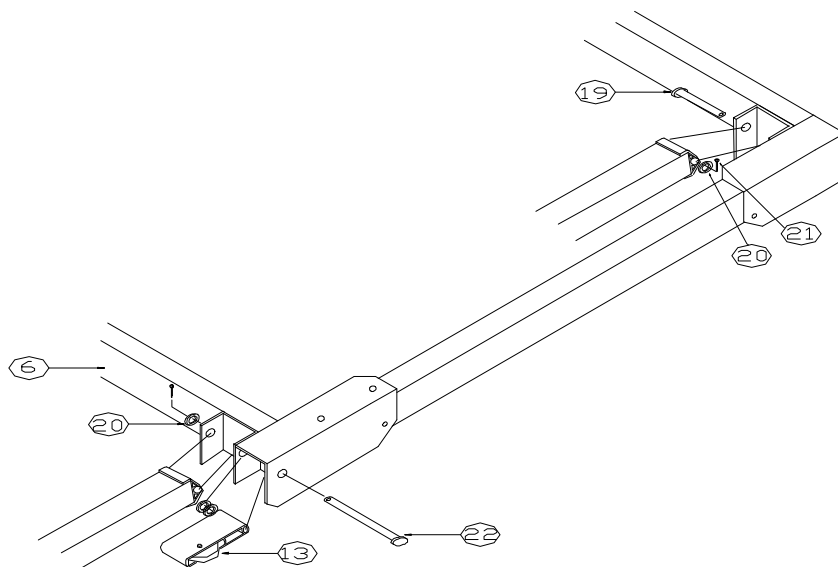

STEP 6. Find the winch (**REF. # 8**) decide what side the winch is going on. The winch is simply turned over to go either left or right. Bolt the winch to the inside of the front upright using 3/8" fender washers (**REF. # 25**) on the tube side and standard 3/8" washers (**REF. # 28**) on the winch side. Use 3/8"x 3" bolts. (**REF. # 29**) Find the lift cable (**REF.NO. 14**), thread the plain end of the cable through the hole in the side of the winch drum.

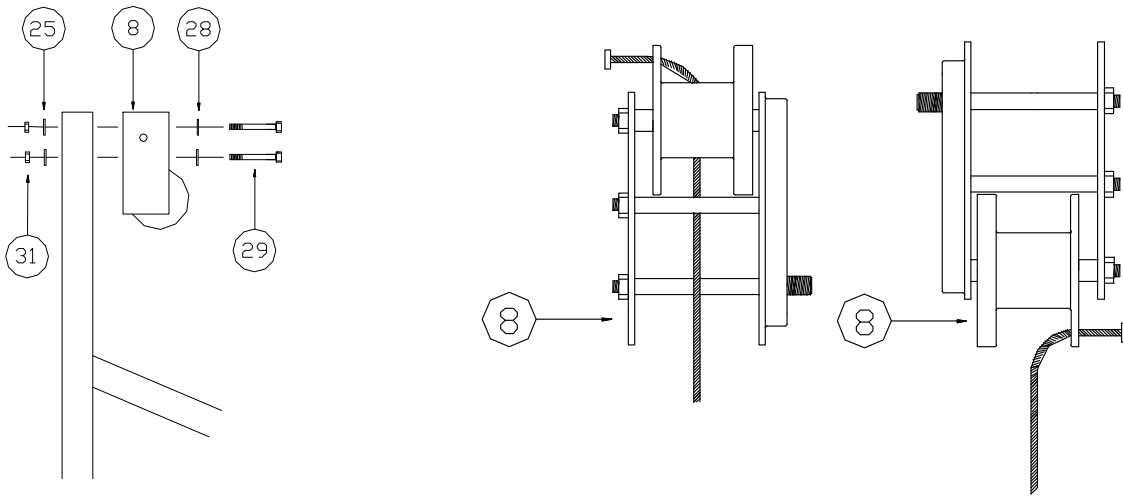

STEP 7. Locate the two round U bolts (**REF. # 23**) and the one pulley and chain assembly (**REF. # 24**). Place the U-bolt through the chain link and into the two holes directly below the winch and above the diagonal tube of the side member. Secure the U bolt with 3/8" fender washers and nylock nuts (**REF. # 25 & 26**). Only finger tighten nuts at this time. Place the other U-bolt through the cable thimble (**REF. # 27**) and secure to opposite side member in the same manner. Pass the cable through the pulley sheave in the pulley bracket. Then run the cable up to and through the pulley on the front bed cross tube across to and through the other pulley. Bring the cable back up to the other U bolt around the cable thimble and secure with cable clamp. (**REF. # 30**). Install lift wheel (**REF. # 9**) on winch and secure with winch hardware. Turning lift wheel clockwise raise the bed of the lift 3/4 of the way up.

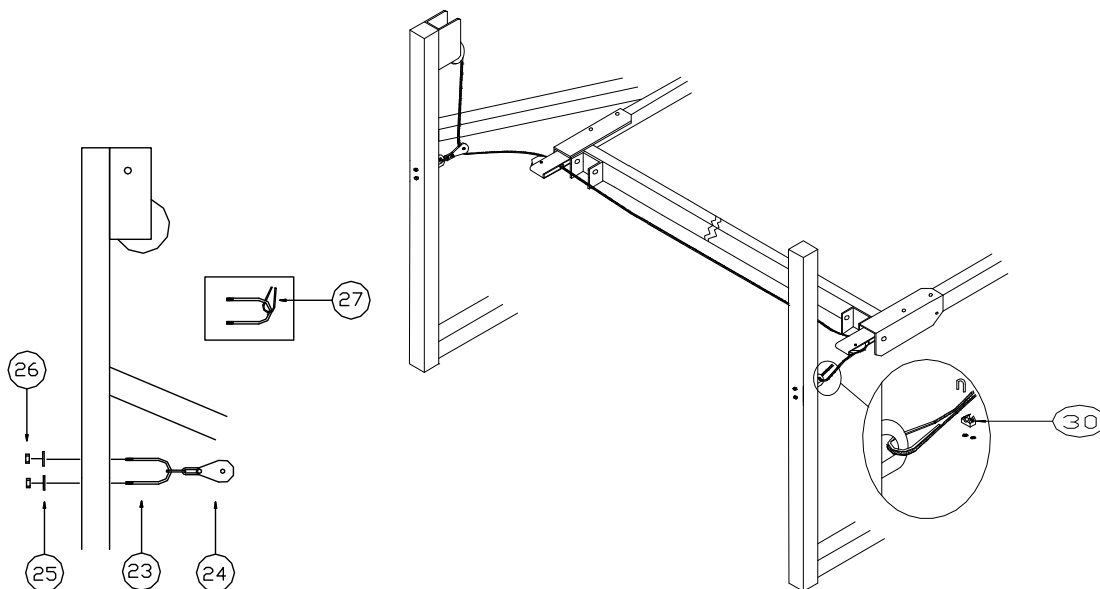

STEP 8. Find the two front angle braces (**REF. # 7**) (description 1 1/4" X 1 1/4" X 36" angle with slotted holes on each end) Bolt the one end to the inside face of the front upright tube with a 3/8" x 3" bolt, washer and nut. (**REF. # 29, 28 & 31**) Bolt the other end to the side of the bottom cross tube using the same size bolt, washer and nuts. Tighten up bottom cross member nut first so that the slot is about in the middle of the bolt. Check front upright for straightness. Adjust upright if necessary and tighten bolt in upright tube

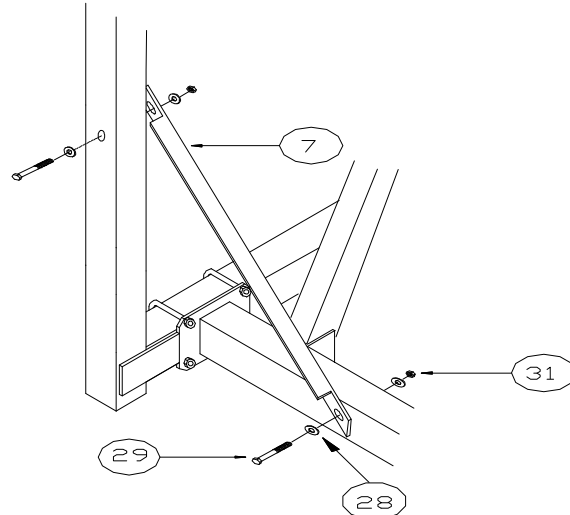

STEP 9. Take the two stop chains (**REF. # 32**) and bolt the one end to the bottom side of the diagonal brace tube of the side member using a 3/8" x 3" bolt (**REF. # 29**) Place the chain link between two 3/8" washers and secure with a 3/8" nylock nut (**REF. # 28 & 26**). Tighten enough so that the nylock nut is fully engaged with the thread of the bolt, yet chain should still turn freely. Fasten the other end of the chain to the inside of the bottom corner of the angle of the top bed cross tube with a 3/8" x 1 1/2" bolt, washers and nylock nut. (**REF. # 33, 28 & 26**) Again tighten the nylock nut so that the nylon of the nut is engaged with the threads of the bolt, but the chain can still turn freely.

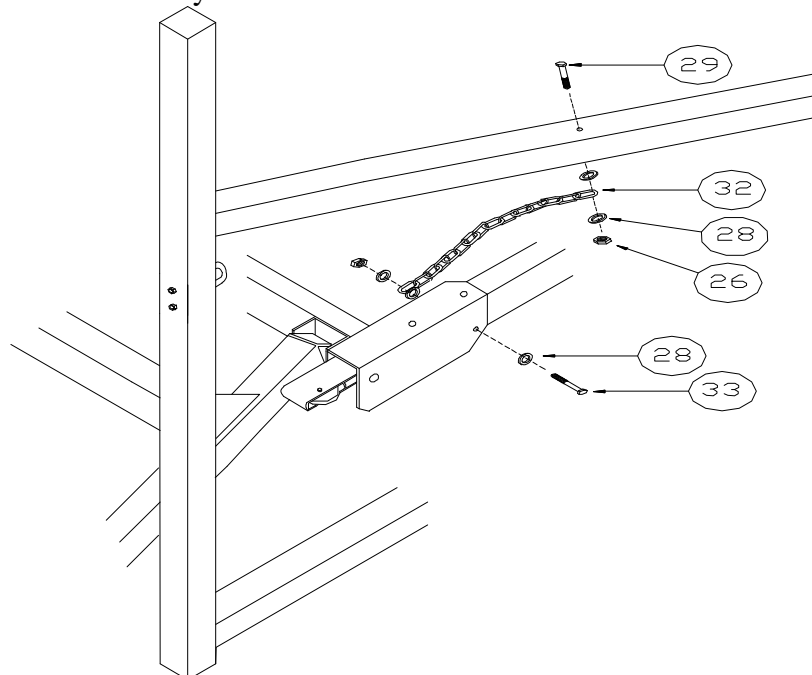

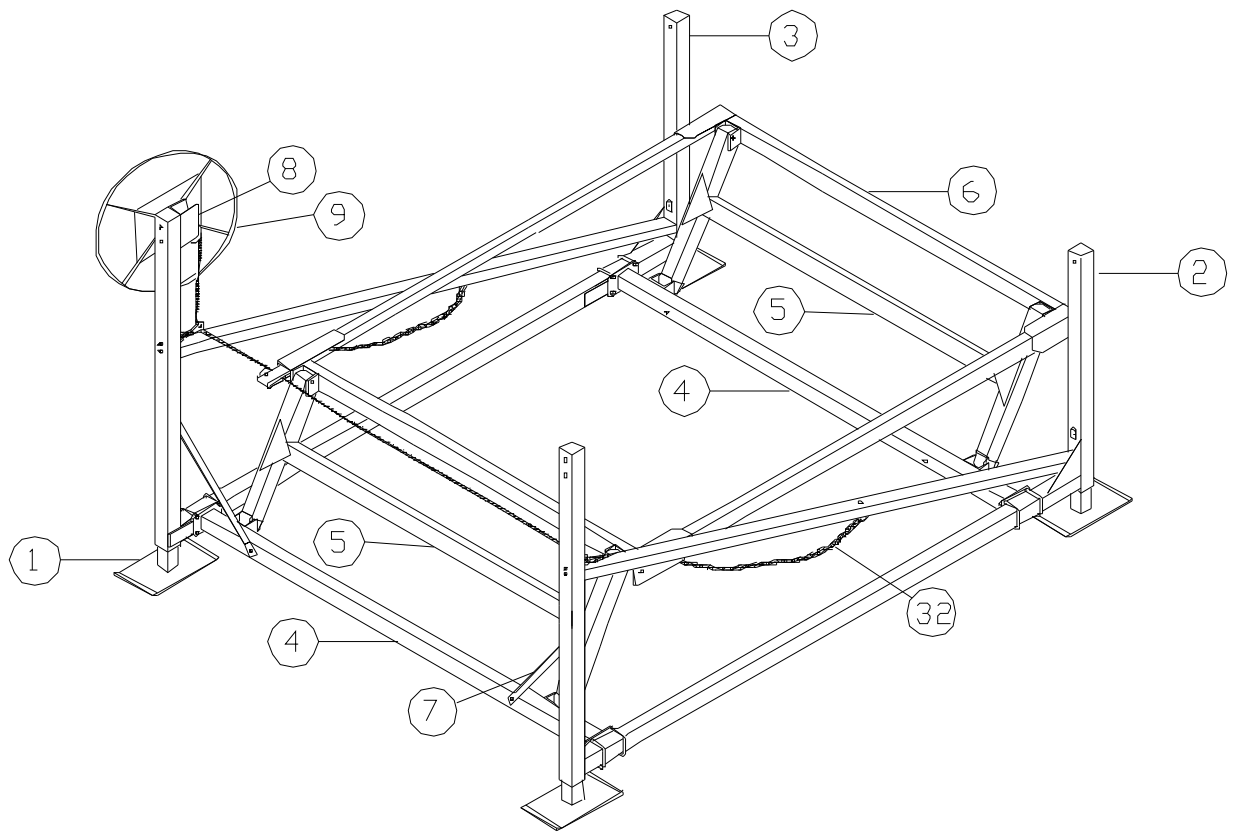

PARTS LIST

100A 1200 LB. 84" WIDE ALUMINUM CANTILEVER BOAT LIFT

102A 1200 LB. 113" WIDE ALUMINUM CANTILEVER BOAT LIFT

<u>REF.NO.</u>	<u>PART NO.</u>	<u>DESCRIPTION</u>	<u>100A</u> <u>1284</u>	<u>102A</u> <u>12113</u>
1	62H	LEVELING LEG	4	4
2	10G	SIDE MEMBER RIGHT	1	1
3	11G	SIDE MEMBER LEFT	1	1
4	12G	BOTTOM CROSS TUBE 1284	2	-
	21G	BOTTOM CROSS TUBE 20113	-	2
5	17G	LIFTING ARMS 1284	2	-
	19G	LIFTING ARM 20113	-	2
6	32H	TOP BED MEMBER 1284	1	-
	07R	TOP BED MEMBER 12113	-	1
7	41218	DIAGONAL FRONT BRACE	2	2
8	3180	WINCH DL B1200	1	1
9	23E	WINCH WHEEL SMALL	1	1
13	99F	PULLEY BRKT 3" X 2.375"	2	2
14	3054	CABLE 1/4" X 26'	1	1
15	4504	SPINNER KNOB	1	1
16	5046	U-BOLT SQ 2"	8	8
17	5156	FLANGE NUT 3/8"	16	16
18	3313	BRASS BUSHING 5/8" X 2"	8	8
19	5097	CLEVIS PIN 1/2" X 3"	6	6
20	5071	WASHER 1/2"	12	12
21	5025	COTTER PIN 1/8" X 1 1/4"	8	8
22	5190	CLEVIS PIN 1/2" X 6"	2	2
23	5034	U-BOLT ROUND	2	2
24	E75	PULLEY 2 1/2" 2 LINK	1	1
25	5067	WASHER FENDER 3/8"	6	6
26	5038	NUT NYLOCK 3/8"	8	8
27	5044	CABLE THIMBLE 1/4"	1	1
28	5070	WASHER 3/8"	20	20
29	5084	BOLT 3/8" X 3"	8	8
30	5004	CABLE CLAMP 1/4"	1	1
31	5056	NUT 3/8" STANDARD	10	10
32	3093	CHAIN STOP 3/16" X 27 LINK	2	2
33	5155	BOLT 3/8" X 1 1/2"	2	2
37	5174	SET SCREW 1/2" X 1"	4	4
38	3821	CAP 2" SQUARE GRAY	3	3
39	3828	CAP .343 X 1/2" PVD	4	4



IMPORTANT BOAT LIFT SAFEGUARDS

The boat lift system must be assembled, installed and operated correctly or mechanical failure causing injury or death may occur. Be sure that all persons operating the lift are familiar with the correct operating procedures and safety guidelines.

CAUTION - Keep all body parts inside the boat when entering or exiting the boat lift. Do not try to manually guide the boat into position.

CAUTION – Keep clear of chains, cables, and all moving parts when operating the lift.

CAUTION – On lifts that have a chain drive winch, the cover must be in place while operating.

CAUTION – Never allow anyone to swim around or climb on the lift structure at any time.

CAUTION – Do not operate the lift with people inside the boat.

CAUTION – Never exceed the rated capacity of the lift as this may cause excessive damage to the lift. Do not allow people to sit in a boat that is on the lift as this may cause the lift's capacity to be exceeded. An uncovered boat can fill up with water and cause the capacity of the lift to be exceeded.

CAUTION – Before any adjustments are made to the lift, or any work is done, the boat must be removed and the bed must be fully lowered.

CAUTION – Winches are pre set from the manufacturer and do not need adjusting.

CAUTION – If using a winch with a remote control, the operator must be close enough to the lift to be sure that no one is around or on the lift, and to be sure that the lift is operating properly

CAUTION - After installation the lift must be leveled in order to operate properly. If the lift is not leveled properly there will be excessive stress on isolated areas causing failure or damage to the lift.

Before installing the lift each year inspect the cables, pulleys, and all moving parts for wear. Immediately replace any part that has excessive wear. Check the brake pad in the winch, if it is worn down to 1/16" thick, cracked, or glazed over, replace it immediately. Check all the bolts to make sure they are tight. On vertical lifts the cables may stretch and will need to be tightened so there is equal tension on all the cables.

Porta-Dock, Inc.