

PART NO.

PAN02
PAN03

DESCRIPTION

APD PANEL CLIP
APPD PANEL CLIP

**Thank you for purchasing our product!
Please read these instructions and follow them step by step.***

TOOL REQUIRED: NONE.

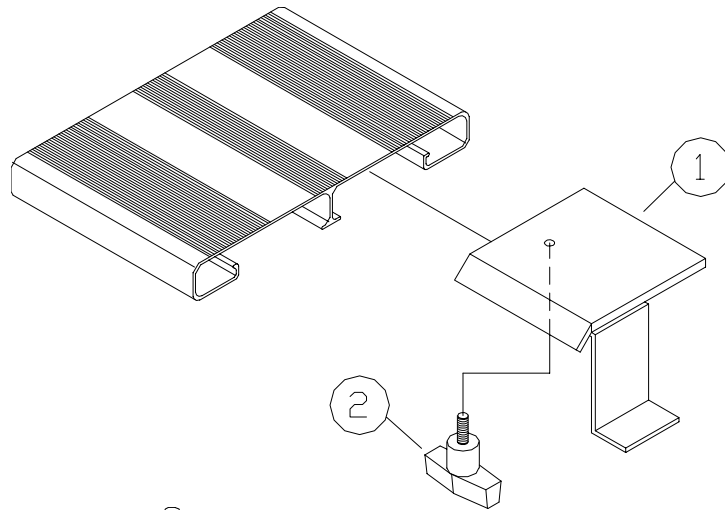

Step 1. Screw bar knob (Ref. No. 2) into the panel clip bracket (Ref. No. 1) so that the threaded stud is flush with the top of the plate. Using the third plank on the aluminum panel slide the APD panel clip into the end of the panel (See Dia.).

Step 2. Slide panel clip in far enough so that the L-Leg of the clip is completely inside the panel and tighten the bar knob.

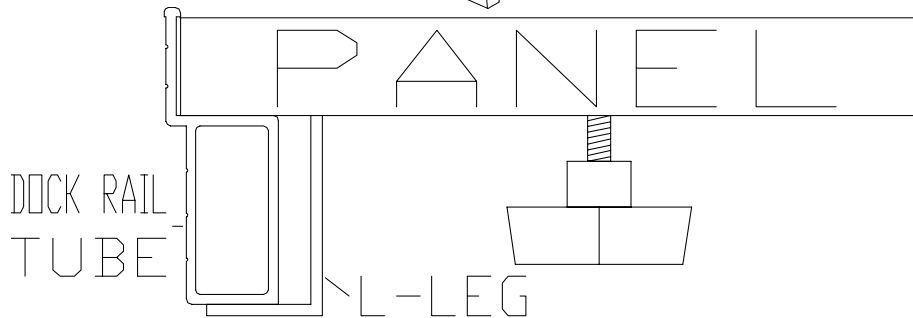

Step 3. Place panel on dock and place in position. Reach under panel and loosen bar knob. Slide panel clip bracket forward until it is tight against the dock rail tube. Re-tighten bar knob

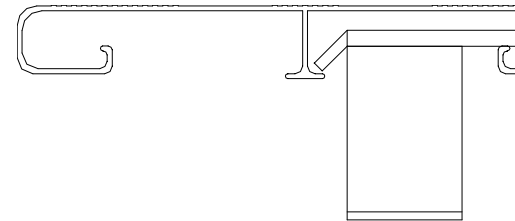

REF. #	PART #	DESCRIPTION	APD PANEL	APPD PANEL
1	73000	PANEL CLIP APD BRACKET	2	-
	75000	PANEL CLIP APPD BRACKET		2
2	5059	BAR KNOB	2	2