

C24 43" HORIZONTAL POST DOCK BUMPER WITH BRACKET

Thank you for purchasing our product!

Please read these instructions and follow them step by step.

STEP 1. Bolt the horizontal post dock brackets (REF. # 1) to the backside of the horizontal bumper (REF. # 2) with 3/8" X 2" bolts and 3/8" washers (REF. # 3 and 4).

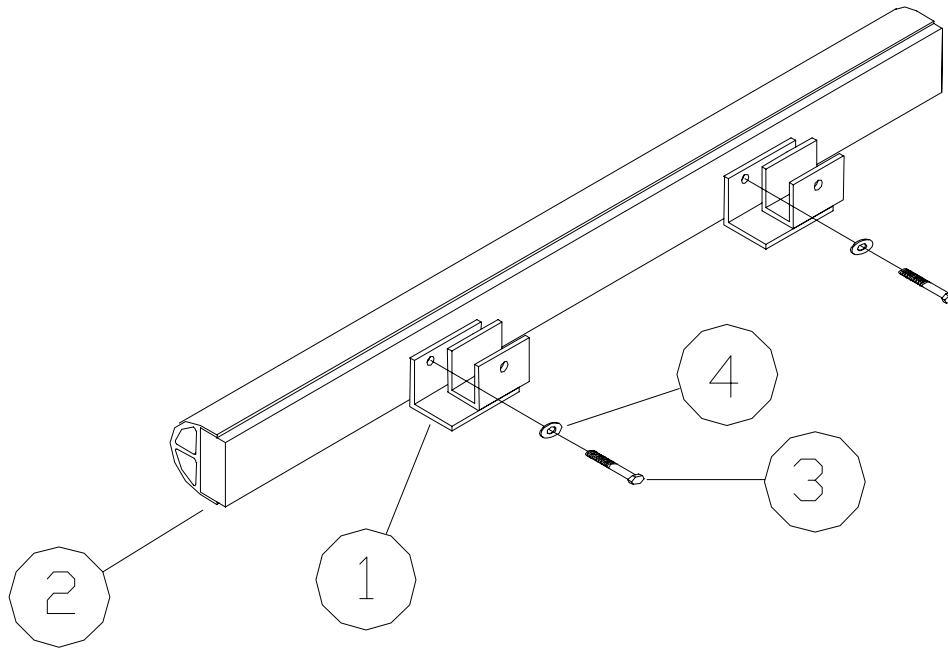

STEP 2. Slip the channel part of the bumper bracket into the frame work of the post dock section and secure in place with 1/2" X 2" set screw (REF. # 5).

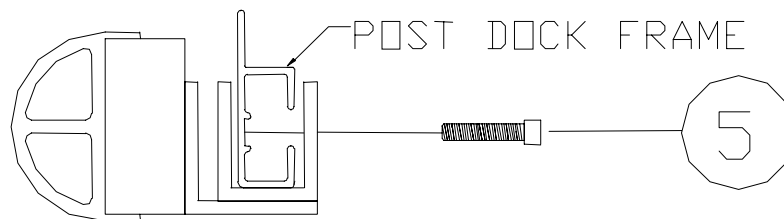

| <u>REF. #</u> | <u>PART #</u> | <u>DESCRIPTION</u> | <u>QTY</u> |
|---------------|---------------|--------------------------|------------|
| 1 | C91 | HORI. PD. BUMPER BRACKET | 2 |
| 2 | C17 | 43" HORIZONTAL BUMPER | 1 |
| 3 | 5082 | 3/8" X 2" BOLT | 2 |
| 4 | 5070 | 3/8" WASHER | 2 |
| 5 | 5173 | 1/2" X 2" SET SCREW | 2 |