

C110 2' DLX MOLDED VERTICAL BUMPER

Thank you for purchasing our product!

Please read these instructions and follow them step by step.

STEP 1. On the backside of the bumper (**REF #1**) there is an indentation at the bottom. Slide two 3/8" x 2 1/2" carriage bolts (**REF # 5**) into the indentation and into the slot.

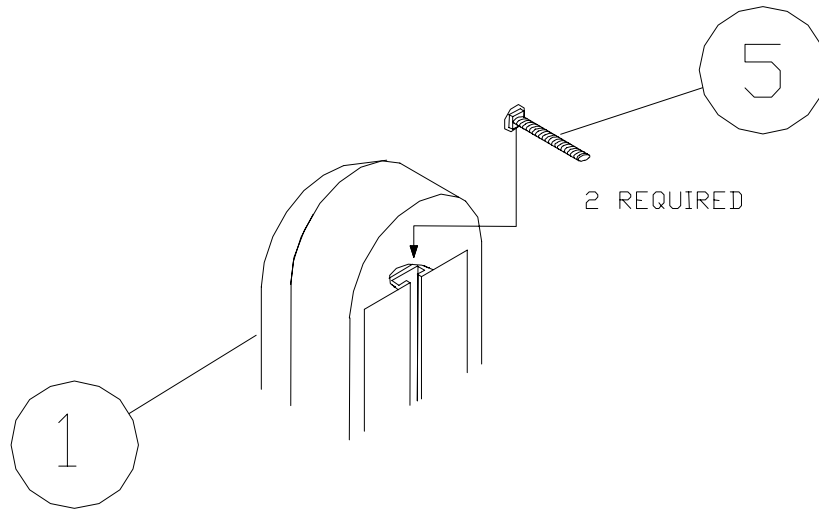

STEP 2. Determine the depth of your dock and the mounting location. Place the bumper spacer (**REF # 7**) onto the carriage bolts using the holes for your applications. Slide bracket to desired height and secure in place with 3/8" flange nuts and washers (**REF # 4 & 3**).

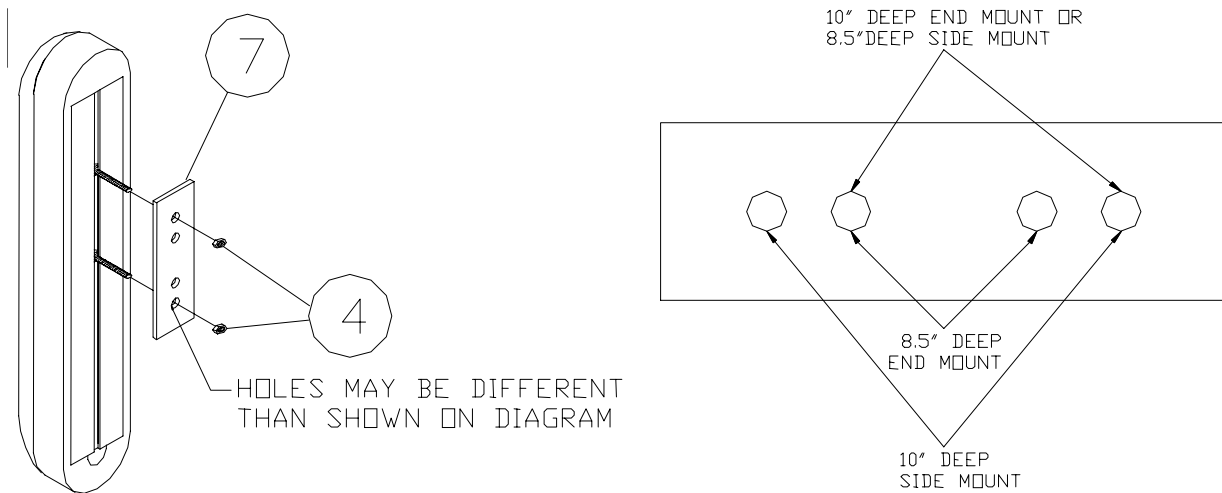

STEP 3. Bolt the bumper to your dock in the desired location. Using the bumper backer angle, secure with 3/8" washers and nuts (**REF # 6, 3 & 2**) as shown.

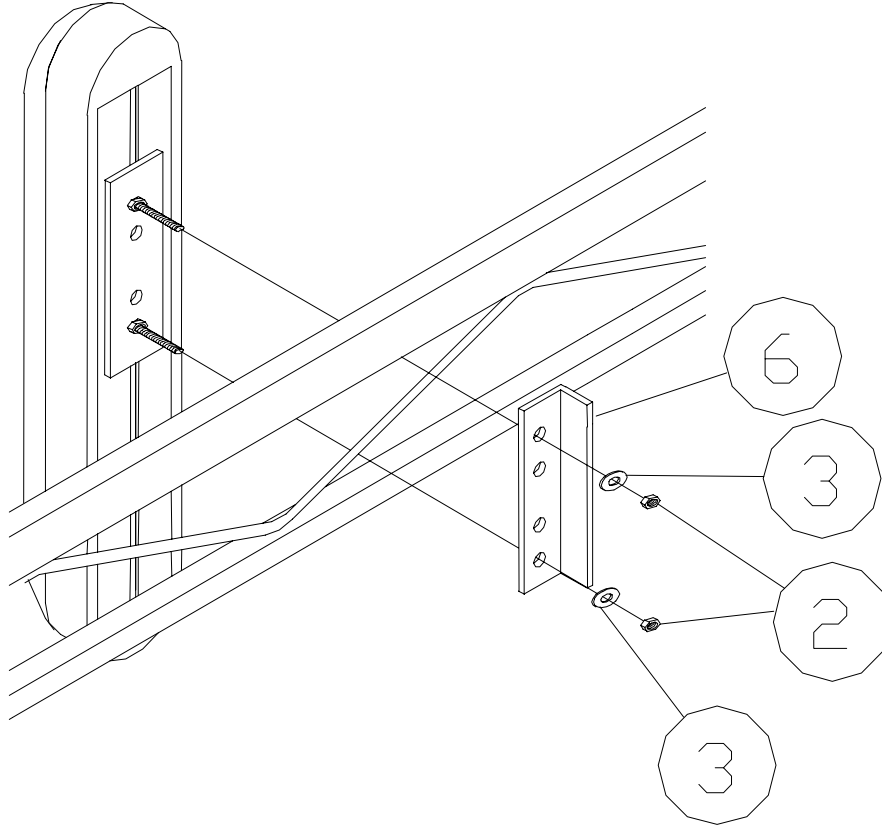

REF. #	PART #	DESCRIPTION	QTY
1	0819	ALUM BUMPER TUBE	1
1a.	3212	BUMPER 24" MOLDED #4	1
2	5056	NUT 3/8"	2
3	5070	WASHER 3/8"	2
4	5156	NUT FLANGE 3/8"	2
5	5195	CARRIAGE BOLT 3/8"X2 1/2" GR2	2
6	60050	BUMPER DLX BACKER ANGLE	1
7	60051	BUMPER DLX SPACER	1