

C04*C04B-H12*H12B*C03*C03B*C13*C13B* BENCH SEAT AND BACK MOUNTING

**Thank you for purchasing our product.
Please read these instructions and follow them step by step.**

Step 1. Bolt the seat (**REF. # 2**) of the bench to the bench sides (**REF. # 1**) using 1/4" X 3 1/2" carriage bolts and nuts (**REF. # 3& 4**). NOTE: The seat of the aluminum bench is the panel with no paint on the underside.

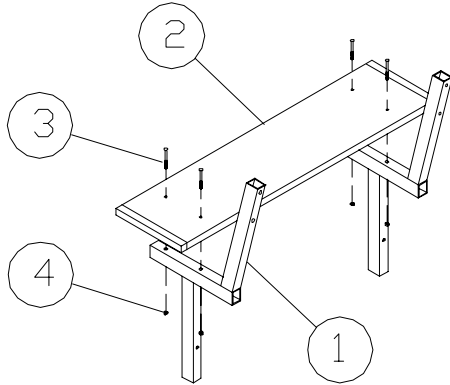

ALUMINUM

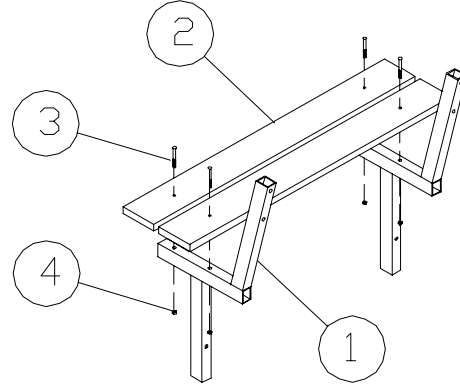

CEDAR

Step 2. Bolt the back of the bench (**REF. # 2**) to the bench sides using 1/4" X 3 1/2" carriage bolts and nuts (**REF. # 3& 4**). Cap the bolts that are sticking through the back of the bench with 1/4" bolt caps (**REF. # 5**). NOTE: if installing the bench with a post dock mounting bracket, install the post dock support bracket onto the backrest support tube before bolting on the backrest (see post dock bracket kit instructions).

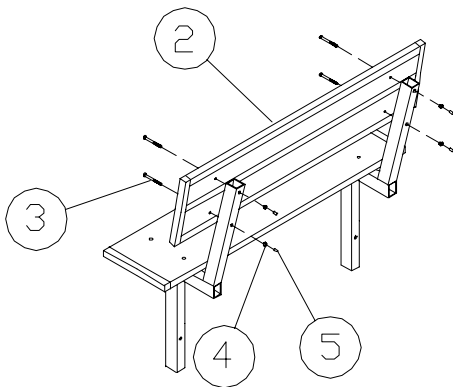

ALUMINUM

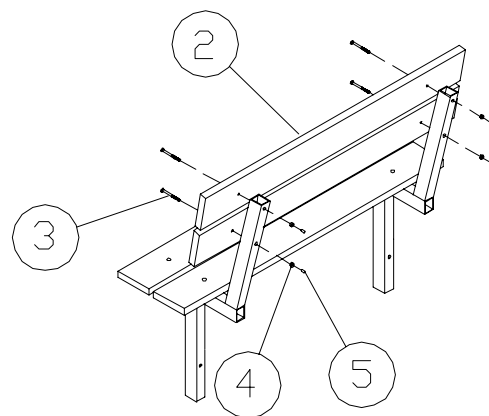

CEDAR

REF. #	Part #	Description	Qty
1	C00	BENCH SIDE	2
2	C70 (B)	ALUMINUM SEAT & BACK 48" WHITE/BEIGE	1
	H12 (B)	ALUMINUM SEAT & BACK 60" WHITE/BEIGE	1
	30200	CEDAR SEAT & BACK 44"	4
	50244	CEDAR SEAT & BACK 56"	4
3	5184	1/4" X 3 1/2" CARRIAGE BOLT	8
4	5055	1/4" NUT	8
5	4509	1/4" CAP	4