

G55 SOLID*G56 BRKT*G57 POST DOCK 48" FIBERGLASS BENCH KIT

For Beige Color Add The Letter B To Model*

**Thank you for purchasing our product.
Please read these instructions and follow them step by step.**

Step 1. Bolt the seat (**REF. # 2**) of the bench to the bench sides (**REF. # 1**) using 1/4" X 3" carriage bolts and nuts (**REF. # 3& 4**). Bolt the back of the bench (**REF. # 2**) to the bench sides using 1/4" X 3" carriage bolts and nuts (**REF. # 3& 4**). Cap the bolts that are sticking through the back of the bench with 1/4" bolt caps (**REF. # 5**). **NOTE:** if installing the bench with a post dock mounting bracket, install the post dock support bracket onto the backrest support tube before bolting on the backrest (see post dock bracket kit instructions).

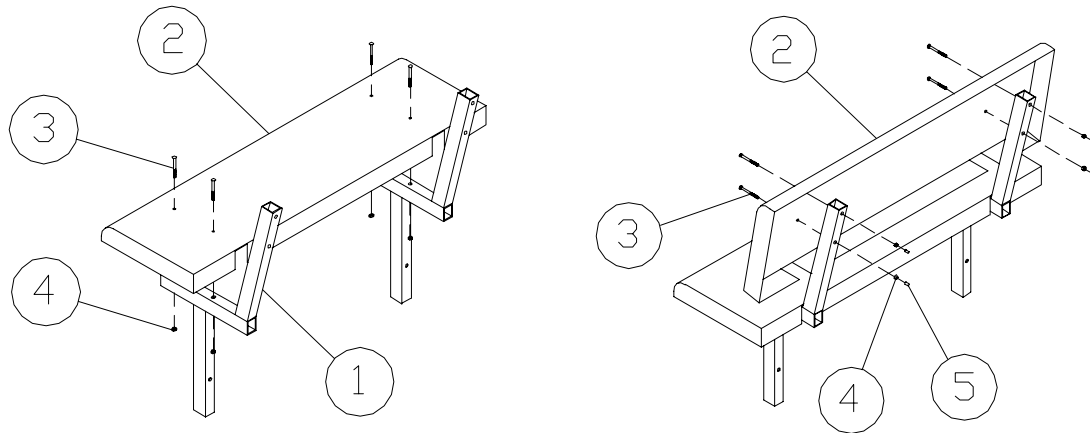

Step 2. Slide the arm rest support tube (**REF. # 8**) onto the bottom tube of the bench side. Set to desired height and secure with 1/2" X 1" set screws (**REF # 6**). Bolt the arm rests (**REF. # 8**) to the flat plate on top of the arm rest support tube using 1/4" X 1" lag bolts (**REF. #7**).



REF. #	Part #	Description	Qty
1	C00	BENCH SIDE	2
2	C100 (B)	BENCH SEAT & BACK FIBERGLASS	1
3	5183	1/4" X 3" CARRIAGE BOLT	8
4	5055	1/4" NUT	8
5	4509	1/4" CAP	4
6	5174	1/2" X 5/8" SET SCREW	2
7	5214	1/4" X 1" LAG BOLT	4
8	46F	4' ARM TUBE	2
9	C100 (B)	ARM REST (INCLUDED W/SEAT & BACK)	2