

***C02 BRACKET BENCH KIT**
C07 WHITE C07B BEIGE ALUMINUM BRACKET BENCH KIT COMPLETE
C73 CEDAR BRACKET BENCH KIT COMPLETE

Thank you for purchasing our product!
Please read these instructions and follow them step by step.

Step 1. Bolt the bench mounting brackets (**REF. # 2**) to the side or end of your dock using 3/8" x 3" bolts, washers, and nuts (**REF. # 5, 6 & 7**) and rear backer angle (**REF. # 3**). Bolt so that you are using the holes that align just below the top tube and above the bottom tube of the dock. The rear backer angle should have the notch end up and away from the top tube. Place washers on both the bolt and nut side. Measure the center of the bench legs and bolt the other bench sides into mounting bracket and secure in place with 3/8" x 2 1/2" bolt (**REF. # 4**).

Step 2. Slide the bench into the pockets and bolt in place with 3/8" X 3" bolt and nut (**REF # 7 & 8**)

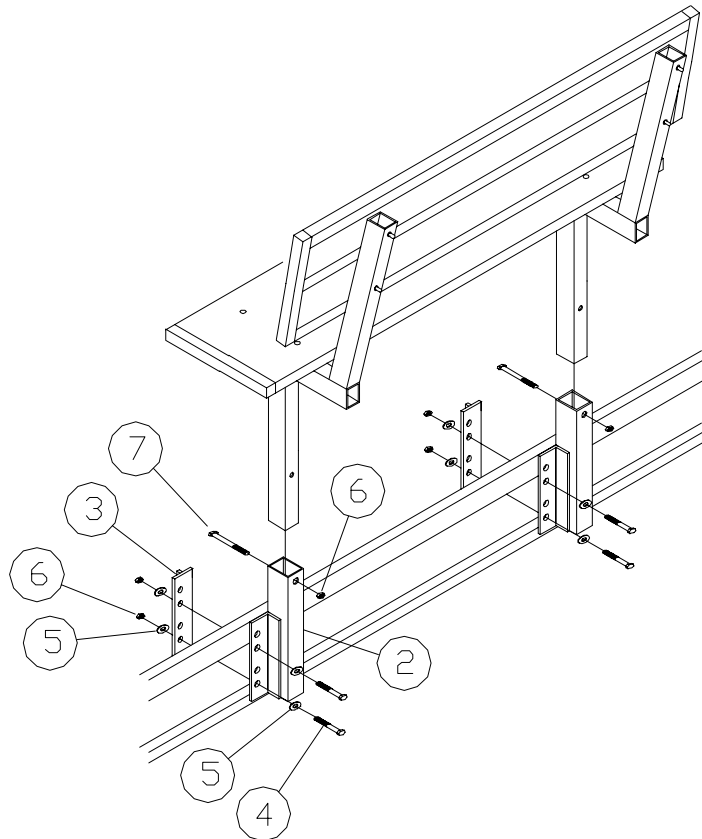

REF. #	PART #	DESCRIPTION	QTY
1	C00	BENCH SIDE	2
2	G12	BENCH MOUNTING BRACKET	2
3	30193	REAR BACKER ANGLE	2
4	5083	3/8" X 2 1/2" BOLT	4
5	5070	3/8" WASHER	8
6	5056	3/8" NUT	6
7	5084	3/8" X 3" BOLT	2
8	5056	3/8" NUT	2