

AA CORNER BENCH C79 & C83

Thank you for purchasing our product.

Please read these instructions and follow them step by step.

Bolt mounting brackets (**REF. # 1**) to the side of the corner section using 3/8" X 2" bolt, washers, and nut (**REF. # 5, 6 & 7**) finger tighten only at this time. Place the bench sides (**REF. # 2**) into the pockets of the mounting brackets. Place a 3/8" X 2 1/2" bolt (**REF. # 8**) through the holes in the pockets and bench leg, fasten bench with 3/8" nut (**REF. # 7**). Tighten all bolts at this time.

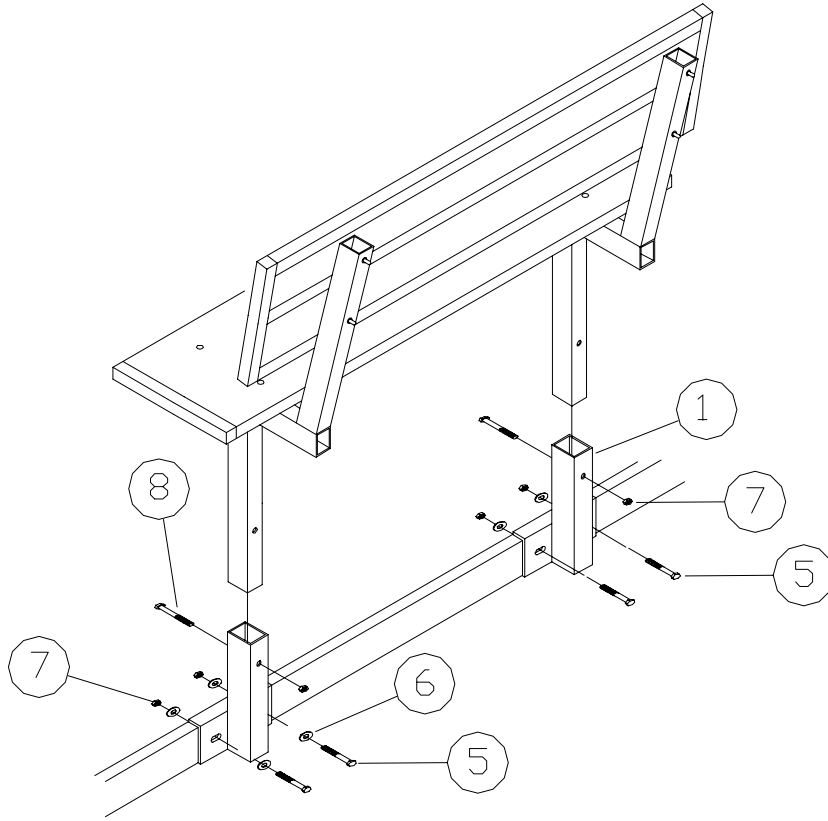

REF. #	Part #	Description	Qty
1	E67	AA Corner Bench Bracket	2
2	C00	Aluminum Bench side	2
5	5082	3/8" x 2" bolt	4
6	5070	3/8" washer	8
7	5056	3/8" nut	6
8	5084	3/8" x 3" Bolt	2