

## 86C

### WHEEL KIT 5000V W/WHEELS (PAIR)

**Thank you for purchasing our product!**

**\*Please read and follow these instructions step by step\***

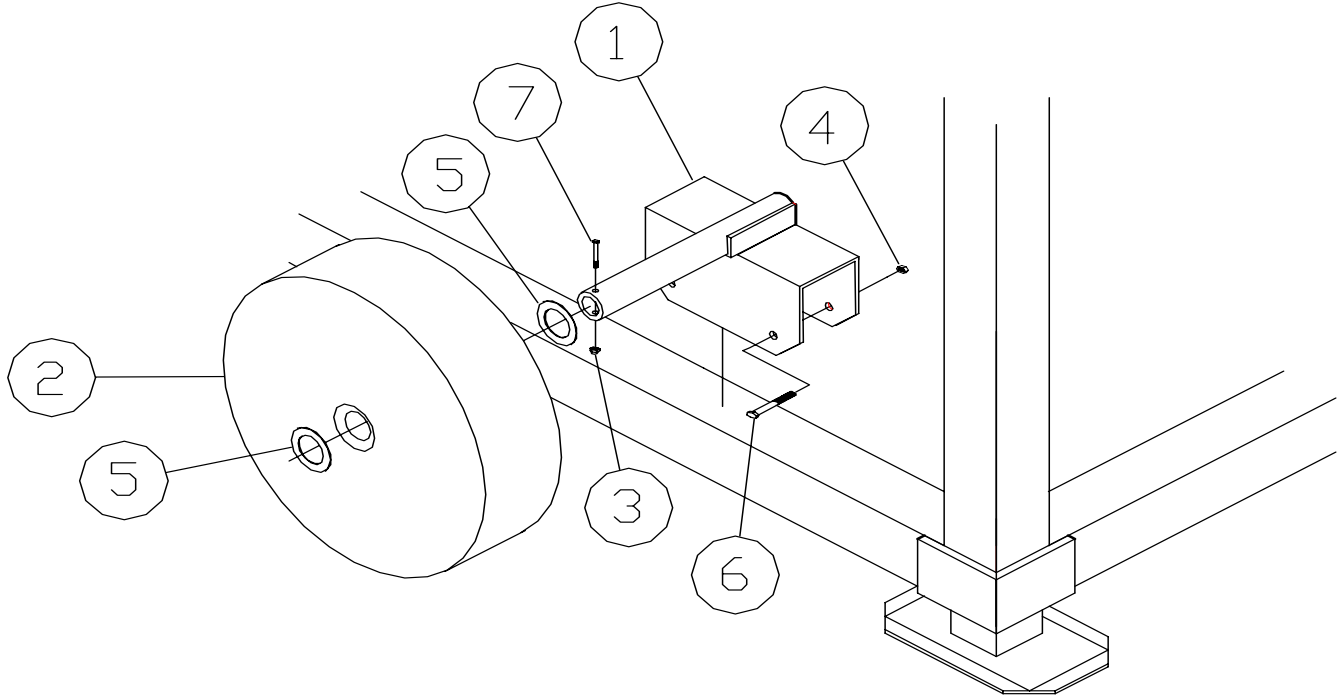

**STEP 1.** Place the wheel bracket (**REF. # 1**) over the bottom side tube, close to the corner upright. Secure with 1/2" X 5" bolts and 1/2" nuts (**REF. # 6 & 4**). Slide a 3" washer (**REF. # 5**) onto the shaft of the wheel bracket, then the tire (**REF. # 2**), then another 3" washer (**REF. # 5**). Secure with 1/4" X 2 1/2" bolt and 1/4" acorn nut (**REF. # 7 & 3**).

**CAUTION:** The weight of the lift must be supported by the leveling legs before the lift is used.

### 86C WHEEL KIT 5000V W/WHEELS (PAIR) PARTS LIST

<u>REF #</u>	<u>PART #</u>	<u>DESCRIPTION</u>	<u>QTY</u>
1	39F	BRACKET 5000V WELDED	2
2	4002	TIRES PLASTIC MOLDED	2
3	5041	NUT 1/4" ACORN	2
4	5058	NUT FIN 1/2"	4
5	5077	WASHER 3" O.D.	4
6	5114	BOLT 1/2" X 5" Gr. 2	4
7	5153	BOLT 1/4" X 2 1/2" GR 2	2