

LIFT CADDY WITH WHEELS
84F 2000 VERTICAL / 2000-3000 CANTILEVER
86F 3000 VERTICAL / 4000 CANTILEVER
88F 4000 VERTICAL

NOT FOR ROAD USE!

Thank you for purchasing our product!
Please read these instructions and follow them step by step.

STEP 1. Raise the bed of the lift so it is out of the way when installing the lift caddy. With lift sitting on a level surface adjust the leveling legs on the lift to approximately 6" high.

STEP 2. Press the two halves of the PVC bushing (**REF. #22**) onto the center shaft of each lift caddy.

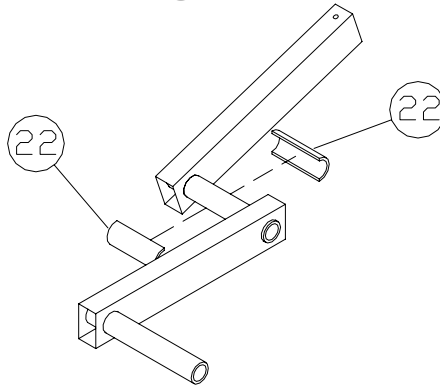

STEP 3. Determine approximately where the balance point of your lift is going to be. On cantilever lifts, it will be about 16" back from the center of the side members. Also, if you have a canopy on, that will affect where your balance point will be located. On the vertical lifts, place the lift caddy next to the winch upright diagonal brace where it meets the bottom tube of the side member. If there is a canopy installed the lift caddy will be between the diagonal braces. Measure where the lift caddy is on the winch side and position the other lift caddy in the same position on the other side.

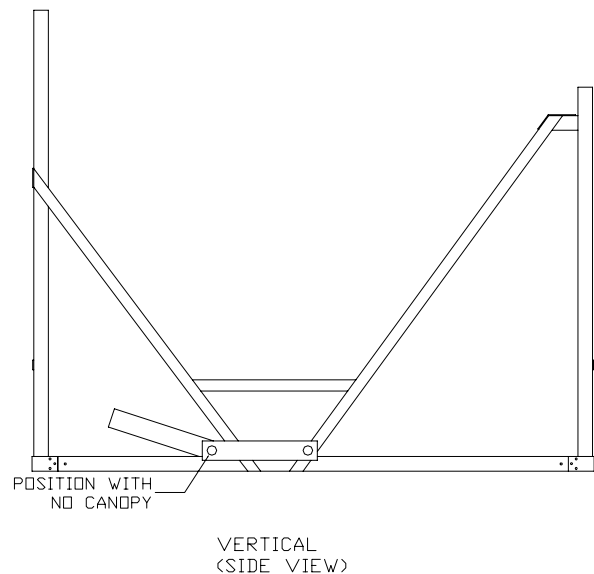
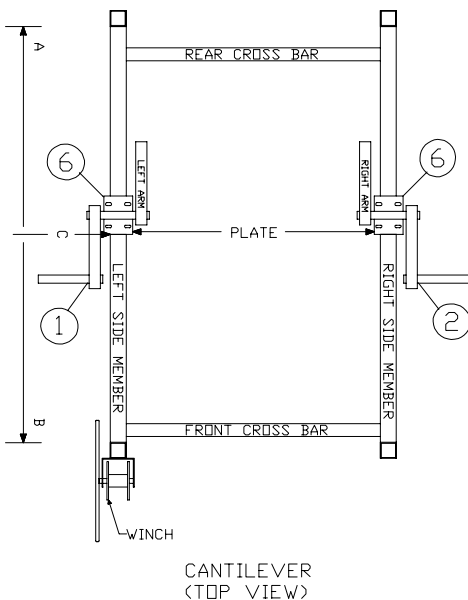

STEP 4. Making sure that you have the stub axle (the tire slides onto this) to the outside of the lift, Fasten the lifting arms and saddle plates (**REF. #5 & 6**) to the bottom side tube of the side member with $7/16''$ U-bolts, washers, and nuts (**REF. #21, 20, & 19**) as shown. Leave nuts loose at this time. Align the arm of the lift caddy so that it is parallel with the bottom tube of the lift side member. Tighten nuts at this time.

NOTE: You can move wheel caddy forward or backwards to change the balance point if necessary.

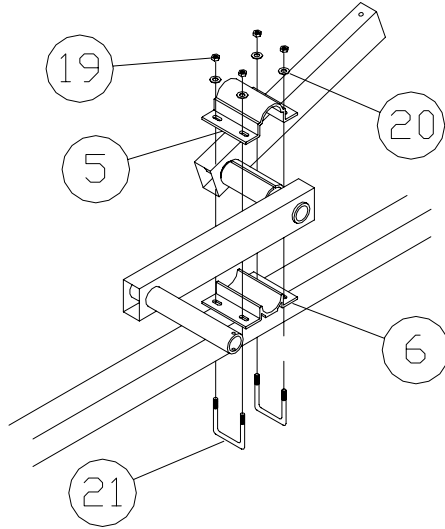

STEP 5. Attach eyebolt (**REF. #8**) to the lifting arm opposite of the stub axle, using $3/8''$ washer and nut (**REF. #9 & #14**). Slide on $3''$ spacer washer (**REF. 16**) onto stub axle, then tire, and another $3''$ washer. Secure in place with $1/4'' \times 2 1/2''$ bolt and acorn nut. (**REF. #12 & 18**)

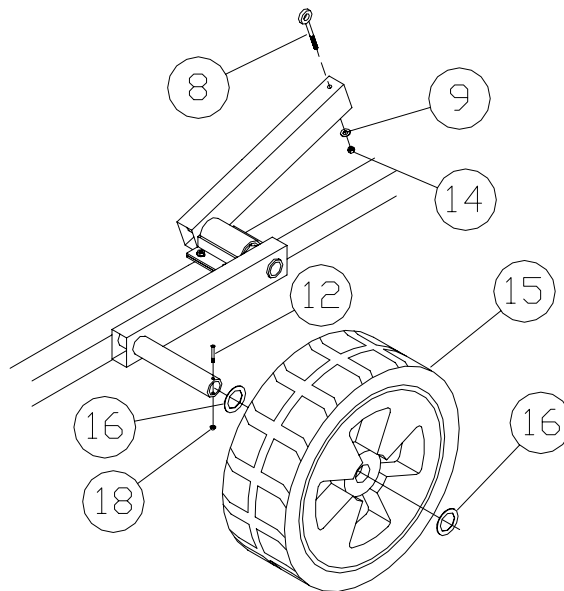

STEP 6. Lower the bed to the lowest position. Place the S-hook bracket (**REF. #7**) over the side bed tube so the bracket is on the wheel side of the saddle plate but the bottom of the bracket will not make contact with it. Place the double chain link (**REF. #17**) onto the 3/8" X 3" bolt (**REF. #13**) so the chain link is in the center of the bracket then secure bolt with 3/8" nut (**REF. #14**). Raise the bed of the lift to the height where you want the lift caddy to start picking up the lift.

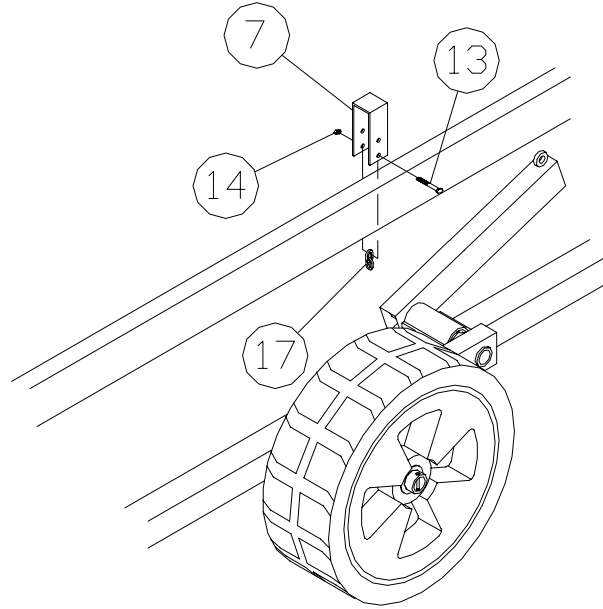

STEP 7. Hook the S-hook into the chain link and slip a 3/16" cable clamp (**REF. #11**) over the other end of the S-hook cable assembly (**REF. #11**). Thread cable through eye bolt and back through cable clamp. Pull cable as tight as possible and tighten clamp. Locate the 1/8" tether cable and 1/8" cable clamps, (**REF. #4 & 10**) Slip cable clamp onto cable and fasten one end of the cable to bottom rear of lift using bottom cross tube or corner of upright tube. Tighten 1/8" cable clamp. With the other cable still connected to the bed of the lift, raise the bed to it's highest position or until the lift caddy arms are in the vertical position. Slide the other 1/8" cable clamp onto cable and then pass cable through eye bolt and then back through cable clamp. Pull cable snug and tighten cable clamp. These tether cables will keep your lift caddy wheels from going over center.

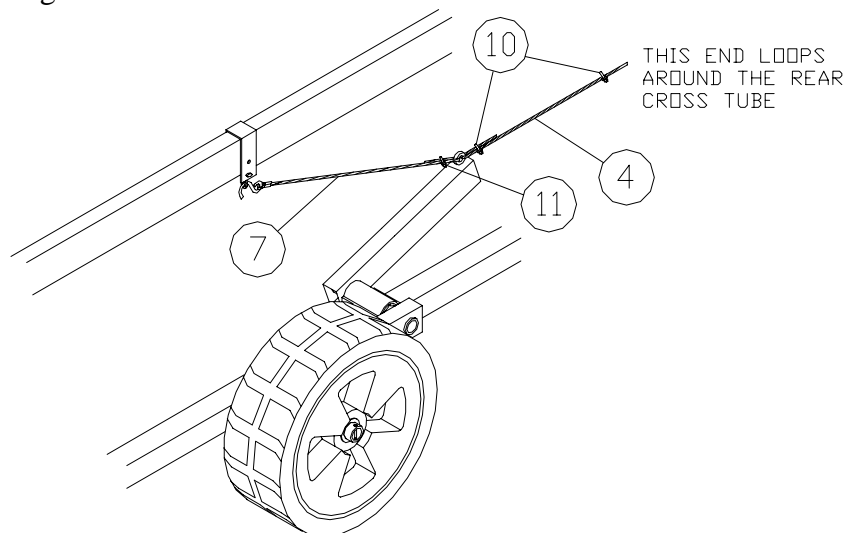

STEP 8. Raise the leveling legs into the uprights so they will not drag or hit anything on the ground when wheeling the lift in or out of the lake. Lower the lift bed watching all cable and bolt connections and making sure the lift wheel caddy is operating correctly. Your lift caddy is now ready for use. With cable S-hook attached to the double chain link while lift is in lower position the wheels are extended by simply raising the lift top bed with the winch. When you wish to retract the wheels simply lower the top bed with the winch until the hooks can be detached. The hooks can then be removed.

***WAVE ACTION MAY CAUSE PREMATURE BUSHING WEAR, FOR THIS REASON YOU MAY WANT TO SECURE OR REMOVE THE WHEELS.**

NEVER USE THE LIFT WHEEL CADDY WITH THE BOAT ON THE LIFT!

NOT FOR ROAD USE!

84F 2000 VERTICAL / 2000-3000 CANTILEVER
86F 3000 VERTICAL / 4000 CANTILEVER
88F 4000 VERTICAL

REF. #	PART #	DESCRIPTION	QTY
1	63F	LIFT CADDY LEFT ARM	1
2	64F	LIFT CADDY RIGHT ARM	1
3	37R	CABLE S-HOOK ASSEMBLY (CABLE 3/16" X 41")	2
4	3061	TETHER CABLE 1/8" X 5'	2
5	80250	TOP SADDLE PLATE	2
6	80251	BOTTOM SADDLE PLATE	2
7	80220	LIFT CADDY S-HOOK BRACKET	2
8	5094	LIFT CADDY EYE BOLT	2
9	5070	3/8" WASHER	2
10	5005	CABLE CLAMP 1/8"	4
11	5003	CABLE CLAMP 3/16"	2
12	5153	BOLT 1/4" X 2 1/2"	2
13	5084	BOLT 3/8" X 3"	2
14	5056	NUT 3/8"	4
15	4002	TIRE PLASTIC MOLDED	2
16	5077	WASHER 3"	4
17	3187	2 LINK CHAIN	2
18	5041	ACORN NUT 1/4"	2
19	5057	7/16" NUT	8
20	5069	7/16" WASHER	8
21	5047	7/16" X 2 9/16" X 3 1/2" SQ. U-BOLT (84F)	4
	5048	7/16" X 3 1/16" X 4" SQ. U-BOLT (86F)	4
	5104	7/16" X 3 9/16" X 4 9/16" SQ. U-BOLT (88F)	4
22	0720	PVC BUSHING 5 1/2"	4