

02C BOAT MOTOR STOP

Thank you for purchasing our product!

***Please read these instructions and follow them step by step. ***

STEP 1. Bolt the motor stop bracket (**REF. NO. 1**) in the center of the rear bed cross tube of the lift with 3/8" X 3 bolts and nuts (**REF. NO. 3 & 4**). Slide the motor stop T-bracket (**REF. NO. 3**) into the tube on the motor stop bracket (**REF. NO. 1**) and secure in desired position with a 1/2" X 1" set screw (**REF. NO. 7**).

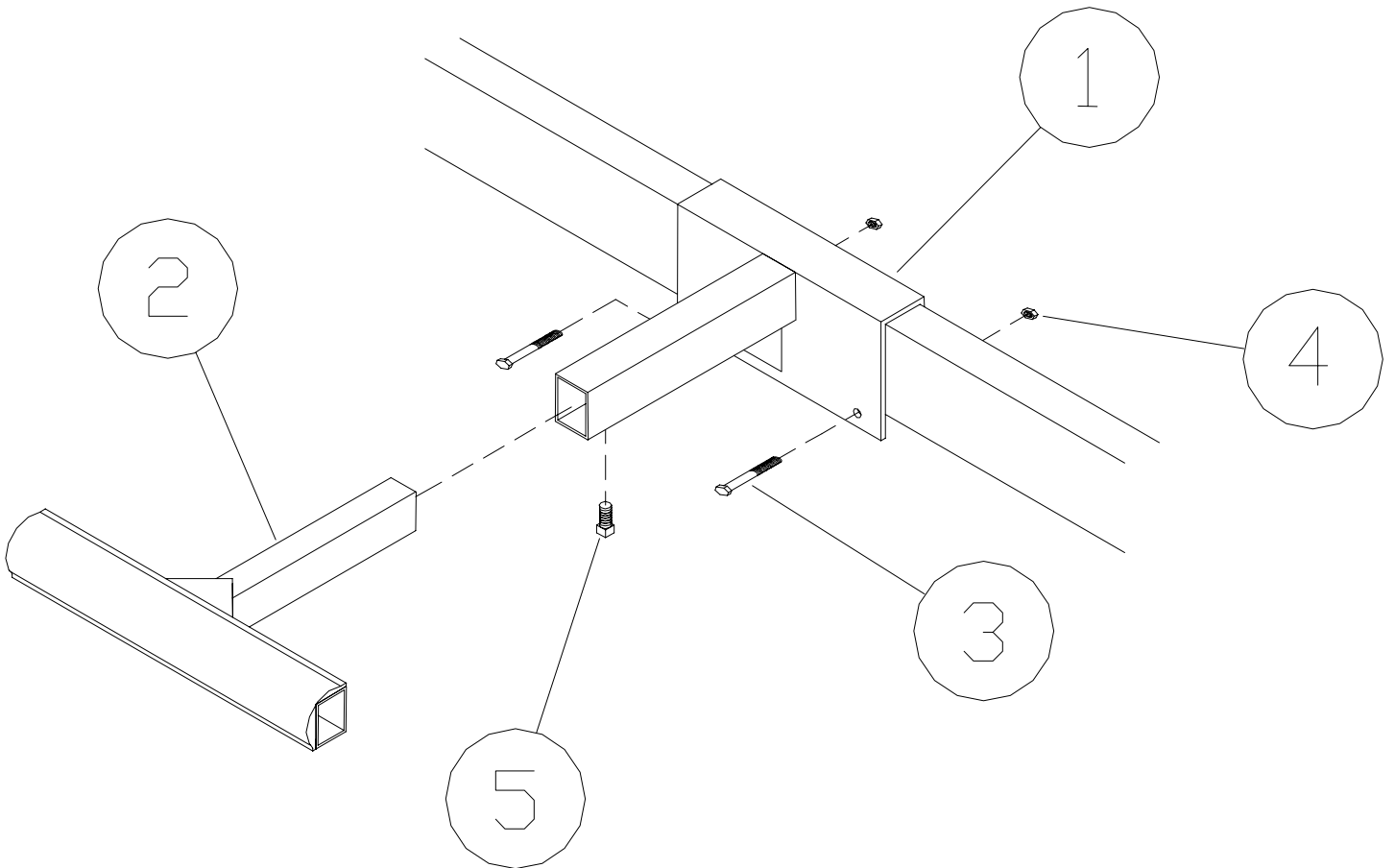

<u>REF. #</u>	<u>PART #</u>	<u>DESCRIPTION</u>	<u>QTY</u>
1	06C	MOTOR STOP BRACKET	1
2	07C	MOTOR STOP T-BRKT & BUMPER	1
3	5084	3/8" X 3" BOLT	2
4	5056	3/8" NUT	2
5	5174	1/2" X 1" SET SCREW	1