

FP24* FW24 4' X 16' END L-SECTIONS
FP26* FW26 4' X 16' END L SECTIONS RIGHT CUTOUT
FP28* FW28 4' X 16' END L SECTIONS LEFT CUTOUT
FP30*FW30 4' X 16' END L SECTIONS DOUBLE CUTOUT
FP44* FW44 4' X 8' END L SECTIONS PKTS LONGSIDE
FP46* FW46 4' X 8' CENTER SECTION

For Beige Decking Add the Letter B to Model

Thank you for purchasing our product!

***Please read these instructions and follow them step by step. ***

STEP 1. Bolt the plastic slide angles (**REF. NO. 1**) into the top holes in the pockets of the dock with 1/4" X 7/8" flat head machine screws and 1/4" keps locknuts (**REF. NO. 6 & 7**).

STEP 2. Place the sections together in the desired configuration and fasten thru the two end holes of the frame with 1/2" X 1 1/4" bolts, 7/16" washers, and 1/2" nuts (**REF. NO. 2, 3, & 4**). Then locate the dock connector bracket (**REF. NO. 5**) and place on the two bottom holes on the outside framework and fasten with 1/2" X 1 1/4" bolts, 7/16" washers, and 1/2" nuts (**REF. NO. 2, 3, & 4**). Once the dock is in position in the lake, slide the posts into the pockets (if using an auger install the auger to the post at this time) and auger or drive the posts into the lake bottom. The posts must be in the lake bottom far enough that the dock is secure.

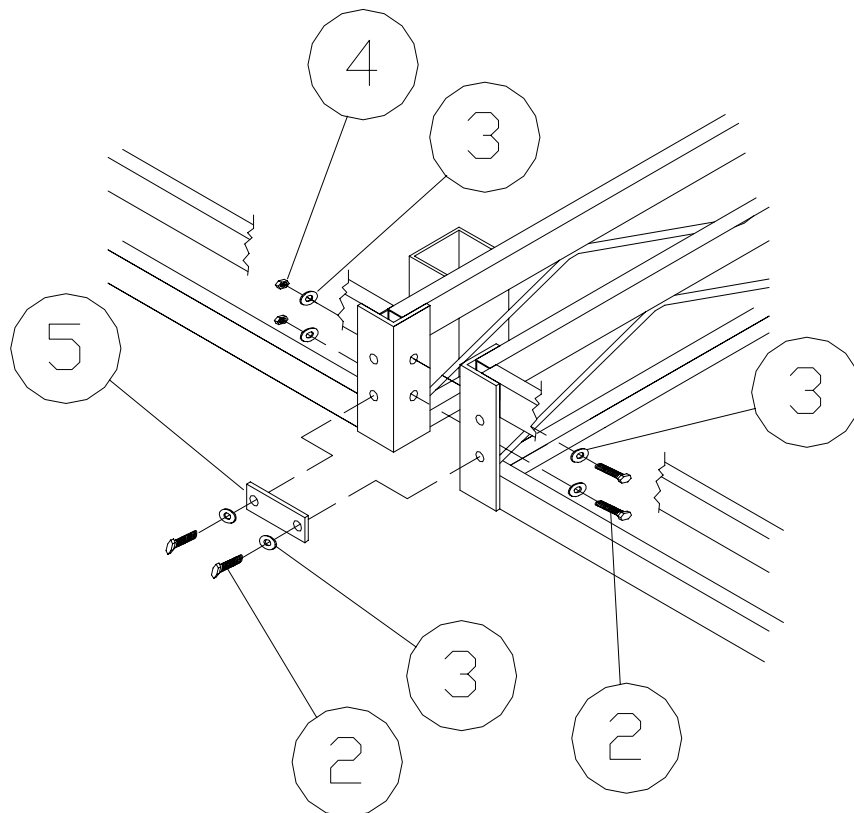
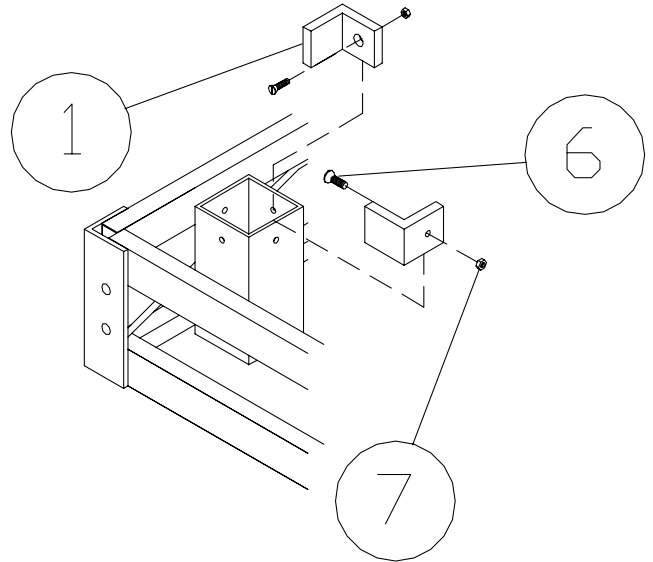

FLOATING DOCK PARTS LIST

<u>REF. #</u>	<u>PART NO.</u>	<u>DESCRIPTION</u>	<u>8'</u> <u>QTY</u>	<u>16'</u> <u>QTY</u>
1	30230	FLOATING POCKET SLIDE ANGLE	4	4
2	5126	1/2" X 1 1/4" BOLT	8	8
3	5069	7/16" WASHER	16	16
4	5058	1/2" NUT	8	8
5	10200	DOCK CONNECTING BRACKET	2	2
6	4994	1/4" X 7/8" MACHINE SCREW	4	4
7	5053	1/4" LOCKNUT	4	4
8		POST		
9	4521	16" PLASTIC EDGING	1	1
10	4108	16' ROLL FOAM TAPE (APD ONLY)	2	4

FRAMES

PART# DESCRIPTION

M42	FRAME APD/CPD 4' X 8' L CENTER SECTION
M44	FRAME APD/CPD 4' X 8' POCKETS LONG SIDE
M50	FRAME APD/CPD 4' X 16' L END SECTION
M52	FRAME APD/CPD 4' X 16' ADD ON
M40	FRAME APD/CPD 4' X 8' ADD ON

PANELS

Add the letter B to the part no. for beige panels.

PART#

DESCRIPTION

B86 (B)	ALUM PANEL 4'X 4' STRAIGHT
FLT01 (B)	ALUM PANEL 4' X 4' RIGHT CUTOUT
FLT02 (B)	ALUM PANEL 4' X 4' LEFT CUTOUT
FLT03 (B)	ALUM PANEL 4' X 4' DOUBLE CUTOUT
B53	CEDAR PANEL 4'X 4' STRAIGHT
FLT06	CEDAR PANEL 4'X4' RIGHT CUTOUT
FLT07	CEDAR PANEL 4'X4' LEFT CUTOUT
FLT08	CEDAR PANEL 4'X4' DOUBLE CUTOUT

TYPICAL L-SECTION DOCK AND FLOAT LAYOUT

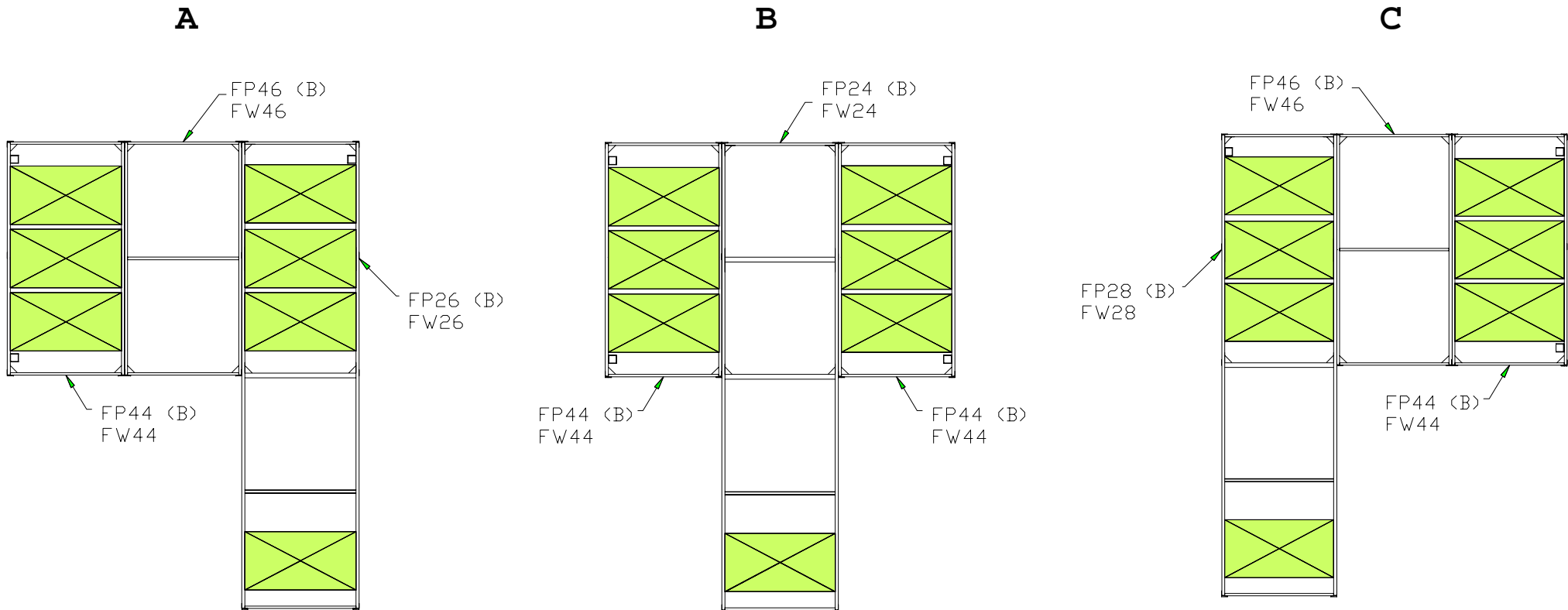

If adding one more L-section to above layouts, you will need two more floats on the additional 8' section. If adding two more L-sections to make a 20' L repeat the 8' section layout as shown.

GENERAL GUIDELINES

- 3 floats per 4' X 16' section on walkway
- 2 floats per 4' X 8' section on walkway
- The L or T end of your dock should be 12 feet or wider for stability
- If the dock is going to be exposed to wave action a hinge should be used every 32' maximum.
- Use a 4' X 8' stabilizer section at approximately the midway point on docks over 64 feet as shown on next page.
- 2" pipe (2 3/8" O.D.) may be used if one slide angle is removed from the pocket.

TYPICAL L-SECTION DOCK AND FLOAT LAYOUT

