

## FLOAT FOR FLOATING DOCKS

**Thank you for purchasing our product!**  
**\*Please read these instructions and follow them step by step.\***

**STEP 1.** Turn the dock section over, so the bottom is up. Position the floats on the dock as shown and bolt in place with four 5/16" X 3" j-bolts, washers, fender washers, and nuts (**REF. NO. 2, 3, 5, & 4**). After all floats are installed, turn the dock section back over so it is right side up.

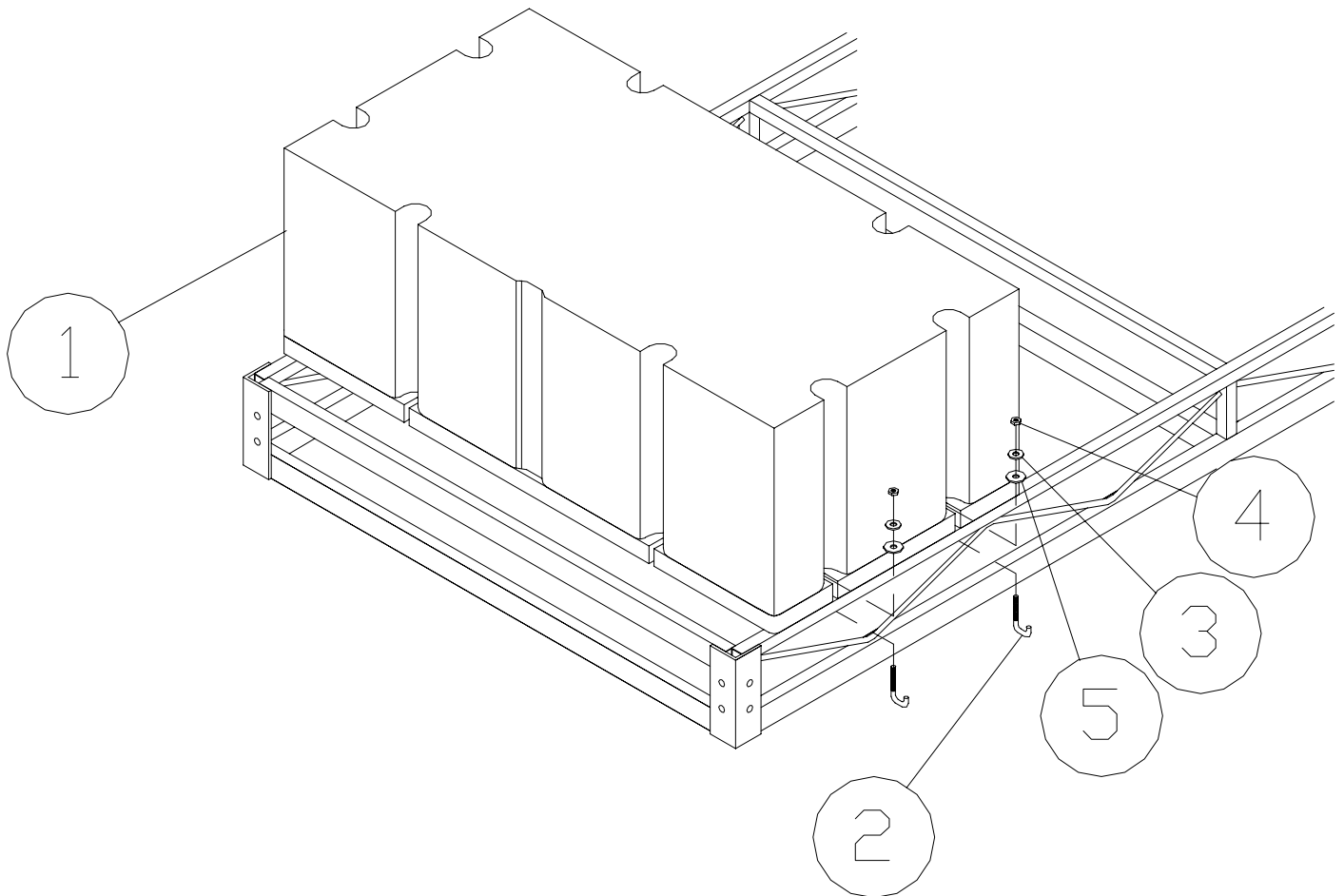

FASTEN THE SAME WAY ON  
THE OTHER SIDE

## FLOATING DOCK PARTS LIST

<u>REF. #</u>	<u>PART NO.</u>	<u>DESCRIPTION</u>	<u>QTY</u>
1	7000	FLOAT 24" X 48" X 16"	1
2	5031	J-BOLT 5/16" X 3"	4
3	5068	5/16" WASHER	4
4	5054	5/16" NUT	4
5	5067	3/8" FENDER WASHER	4