

## A82 APD & A90 CPD L10 5' X 16' ALUMINUM PORTA-DOCK

**\*For Beige Decking Add the Letter B to Model\***

**Thank you for purchasing our product!**

**\*Please read these instructions and follow them step by step.\***

**STEP 1.** Take the 5' x 8' section (**REF.#34**) and tip it up on it's side so that the pockets are on top. Slide an 8' support post (**REF.#23**) into each end pocket and hold in place with  $\frac{1}{2}$ " x  $\frac{3}{4}$ " setscrew (**REF.#6**). Decide if you want your L dock to the right or left. Lay the 8' section (**REF.#30**) to that side of the 16' wheel end section. Bolt 8' L section to the side of the 16' wheel end section using  $\frac{1}{2}$ " x  $1 \frac{1}{4}$ " bolts and nuts (**REF.#20 & 3**). Bolt the center of the 8' section to the inside pocket of the 16' section using  $\frac{1}{2}$ " x  $2 \frac{1}{2}$ " bolts and nuts (**REF.#15 & 3**).

Raise and block dock frame up about 30" (on the 8' L side you can use the support post to hold that side up). Then bolt winch (**REF.#11**) with three  $\frac{3}{8}$ " x 1" bolts and nuts (**REF.#18 & 2**) to the outside winch plate of the 16' section with the winch handle stub to the outside. Bolt winch on in the same manner to the outside of the 8' section.

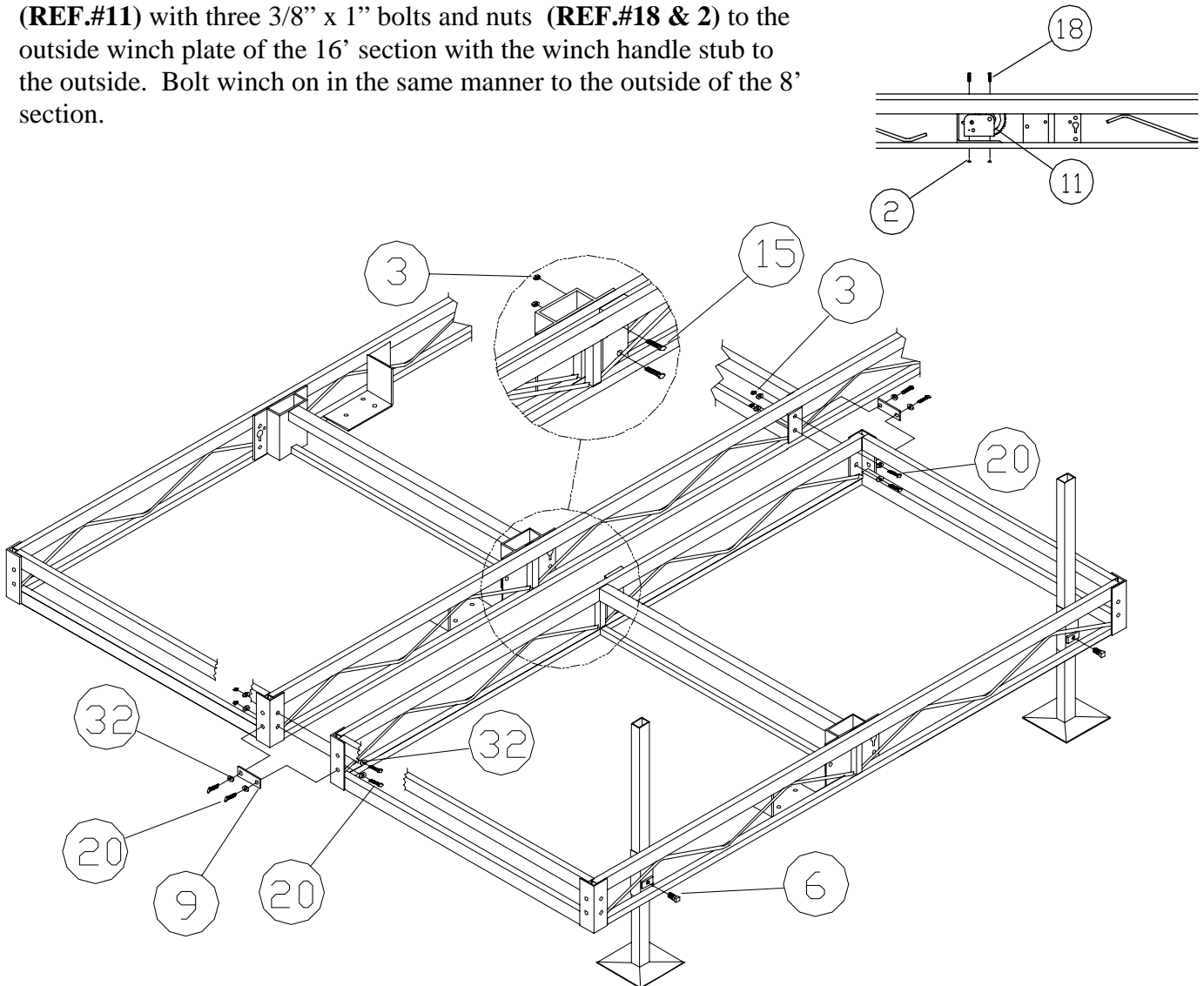

**STEP 2.** Apply the four nylon wear strips (**REF.#29**) to the inside narrow ends of the pockets. Pockets should be clean and dry and the above 50 degrees. Slide a VLM cover plate (**REF. #38**) onto each vertical lift member. Attach dock pulleys (**REF.#14**) with 1/2" x 2 1/2" bolts and nuts (**REF.#15 & 3**) to top of vertical lift members (**REF.#7**). Insert vertical lift members into pockets on each side of dock. Secure with setscrew (**REF.#6**) into the face of the pockets. Leave all setscrews loose at this time

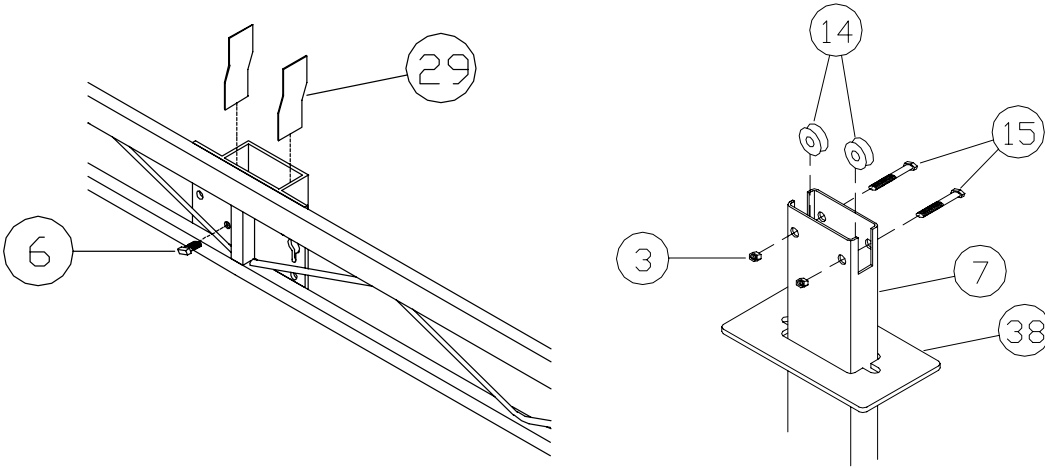

**STEP 3.** Attach chain (**REF.#16**) to inside holes of axle (**REF.#10**) with 3/8" x 3" bolts and nuts (**REF.#19 & 2**). Slide on 3" washers (**REF.#8**). Slide the wheels (**REF.#4**) with the protruding hub to the outside on the axle, up to the 3" washers, then the lift member brackets (**REF.#13**). Place the 1/4" x 2 1/2" bolt (**REF.#1**) in the holes in the ends of the axle and screw on the 1/4" acorn nut (**REF.#1A**). Roll axle under dock, keeping axle centered with dock. Bolt lift member bracket (**REF.#13**) to vertical lift members (**Ref. #7**) with 3/8" x 3" bolts and nuts (**REF.#19 & 2**).

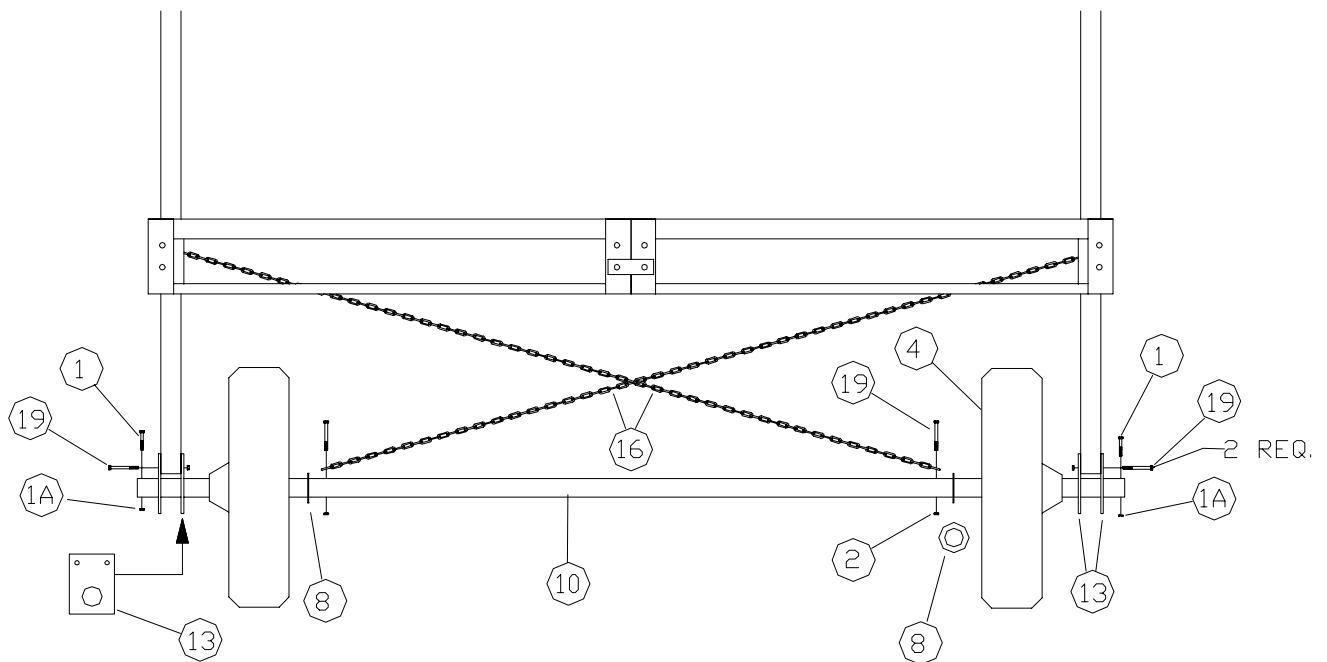

**STEP 4.** Attach winch handles (**REF.#27**) with winch nut (**REF.#28**). Attach lower dock pulleys (**REF.#14**) between pocket and ear tab located on the winch side of the vertical lift member pocket with  $\frac{1}{2}$ " x  $2 \frac{3}{4}$ " clevis and cotter pins (**REF.#21 & 17**). Starting winch cable (**REF.#12**) from the outside of the winch, pass cable through the holes on the side of the drum with the gears. Run cable through lower pulley (**REF.#14**), then up to pulleys (**REF.#14**) on the vertical lift members, and down to holes on side of the vertical lift member bracket. Fasten with cable clamp (**REF.#5**). Work winches until cables are raising dock.. You must alternate winches as dock moves up or down and you must have slack in the chain when raising the dock.. Place VLM pulley cover (**REF.#23**) on to the vertical lift members and caps on the 8' support posts (**REF.#24**)

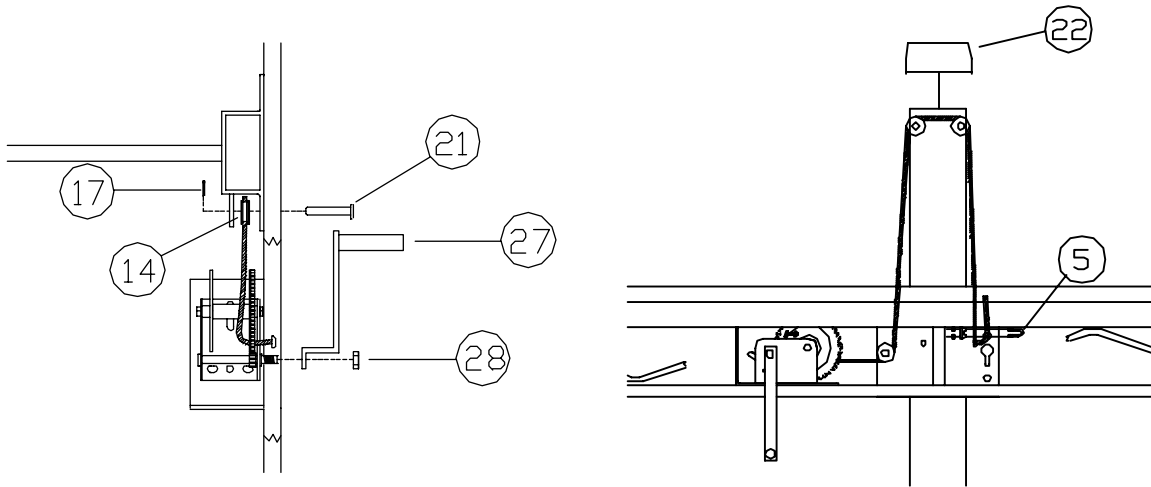

**STEP 5.** Raise dock high enough to be able to work under it. Bring ends of chain (**REF.#16**) up to the opposite side of dock, through the keyhole bracket located on the vertical lift member pocket and lock in position by sliding the chain link down the keyhole slot.

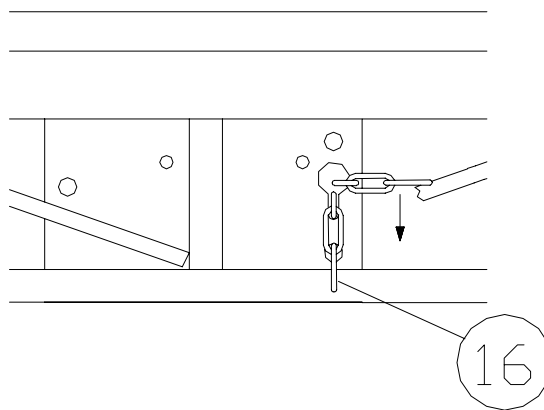

**NOTE:**

After the panels are installed in the dock, slide a cover plate (**REF.#35**) over each dock post and onto the deck.. Place a rectangular post cap (**REF.#24**) onto each post. When the dock is at desired height, chains should be tight. If the chains are not tight, lower dock 3” to 4” and tighten chains. Raise the dock back to desired height and recheck the tightness of the chain.

**Always loosen set screws and chain** before changing dock height. You must alternate winches as dock moves up or down. When moving dock into and from lake, lower dock to lowest level possible.

Secure set screws until snug against inside leg. Tighten 1 ½” to 2 turns more. Check set screws after a couple of uses and retighten if necessary.

REF.#	PART#	DESCRIPTION	APD	CPD
1	5153	¼" X 2 ½" BOLT	2	2
1A	5041	¼" ACORN NUT	2	2
2	5056	3/8" NUT	12	12
3	5058	1/2" NUT	14	14
4	4002	TIRE PLASTIC MOLDED	2	2
5	5003	3/16" CABLE CLAMP	2	2
6	5170	1/2" X 3/4" SET SCREW	4	4
7	30084	VERTICAL LIFT MEMBER	2	2
8	5077	3" WASHER	2	2
9	10200	5' CONNECTOR BRACKET	2	2
10	30181	AXLE FOR L10 5' DOCK	1	1
11	3005	DL 1100 WINCH	2	2
12	3050	3/16" X 15' CABLE	2	2
13	30088	LIFT MEMBER BRACKET	4	4
14	3300	1 1/2" PULLEY SHEAVE	6	6
15	5120	1/2" X 2 ½" BOLT	6	6
16	3089	3/16" X 11' 6" CHAIN	2	2
17	5025	1/8" X 1" COTTER PIN	2	2
18	5081	3/8" X 1" BOLT	6	6
19	5084	3/8" X 3" BOLT	6	6
20	5126	1/2" X 1 ¼" BOLT	8	8
21	5008	1/2" X 2 ¾" CLEVIS PIN	2	2
22	3804	VLM PULLEY COVER	2	2
23	C30	8' ALUMINUM DOCK POST	2	2
24	3803	RECTANGULAR POST CAP	2	2
27	3008	DL WINCH HANDLE	2	2
28	5066	DL WINCH NUT	2	2
29	4112	8 1/2" VLM WEAR PAD	4	4
30	4108	APD FOAM TAPE 16' ROLL	5	-
31	3840	COVER PLATE APD WHITE	2	-
	3845	COVER PLATE APD BEIGE	2	-
	3841	COVER PLATE CPD	-	2
32	5069	7/16" WASHERS	16	16
33	F94	5' X 16' WHEEL END FRAME	1	1
34	F97	5' X 8' L10 FRAME	1	1
	B68	5' X 4' CEDAR L10 WH END LEFT CUTOUT -	1	-
	B69	5' X 4' CEDAR L10 WH END RIGHT CUTOUT	-	1
	B31	5' X 4' CEDAR L10 L SECTION LEFT CUTOUT	-	1
	B44	5' X 4' CEDAR L10 L SECT. RIGHT CUTOUT	-	1
	B10	5' X 4' CEDAR STRAIGHT	-	1
	B73 (B)	5' X 4' ALUM. L10 WH END LEFT CUTOUT	1	-
	B81 (B)	5' X 4' ALUM. L10 WH END RIGHT CUTOUT	1	-
	B67 (B)	5' X 4' ALUM. L10 SECTION LEFT CUTOUT 1	-	-
	B66 (B)	5' X 4' ALUM. L10 SECTION RIGHT CUTOUT	1	-
	B13 (B)	5' X 4' ALUM. STRAIGHT	1	-
38	3850	VLM COVER PLATE APD WHITE	2	-
	3851	VLM COVER PLATE APD BEIGE	2	-
	3852	VLM COVER PLATE CPD BROWN	-	2