

AD15 AA DS & AP15 APD DS 4' X 16' L12
AW15 CPD DS 4' X 16' L12

For Beige Decking Add the Letter B to Model

Thank you for purchasing our product!

***Please read these instructions and follow them step by step. ***

STEP 1. Decide if you want your L dock to the right or left. Lay the 8' section with no pockets (**REF. # 32**) to the side of the 16' wheel end section (**REF. # 26**). Bolt 8' section to the side of the 16' wheel end section using 1/2" x 1 1/4" bolts, washers and nuts (**REF. # 20, 36 & 3**).

Bolt dock connector brackets (**REF. # 9**) to the lower side holes of the angle with 1/2" x 1 1/4" bolts, washers and nuts. Next slide two support posts (**REF. # 24**) into the two outside corner pockets of the 8' section with the three pockets (**REF. # 30**). Bolt the 8' section to the side of the other 8' section in the same manner as before. Put the set screws (**REF. # 6**) into the pockets. Bolt the center of the middle 8' section to the center of the outside 8' section and to the inside pocket of the 16' section using 1/2" x 2 1/2" bolts and nuts (**REF. # 15 & 3**).

NOTE: If assembling an AA dock, the center will have to be bolted together after step 5 when the dock is raised off the ground. Block the dock up about 2' behind winches on both the 8' and 16' sections.

Bolt winch (**REF. # 11**) with 3/8" x 1" bolts and nuts (**REF. # 18 & 2**) to the winch plate with winch handle stub to the outside. Then bolt winch on in the same manner to the outside side of the section.

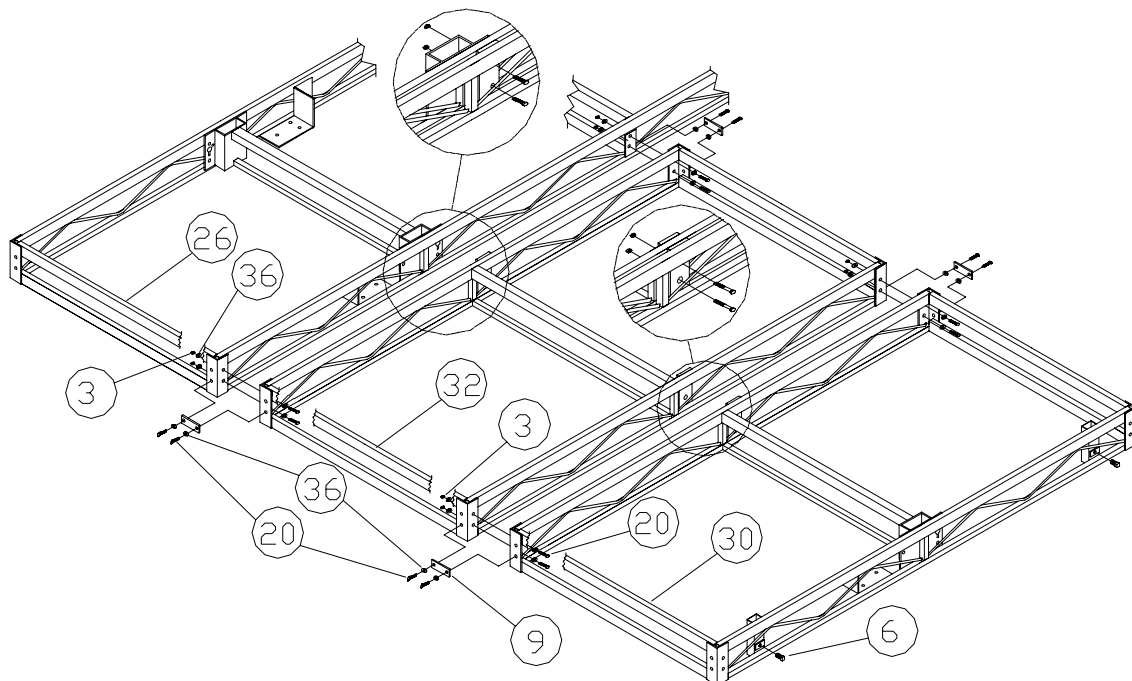
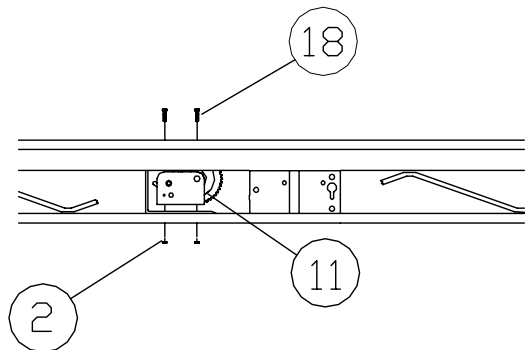

STEP 2. Apply the four nylon wear strips (**REF. # 33**) to the inside narrow ends of the large vertical lift member pockets. Pockets should be clean and dry and above 50 degrees. Slide a VLM cover plate (**REF. # 38**) onto each vertical lift member. Attach the dock pulleys (**REF. # 14**) with 1/2" x 2 1/2" bolts and nuts (**REF. # 15 and 3**) to top of vertical lift members (**REF. # 7**). Insert vertical lift members into pockets on each side of dock. Screw in set screws, leave loose at this time.

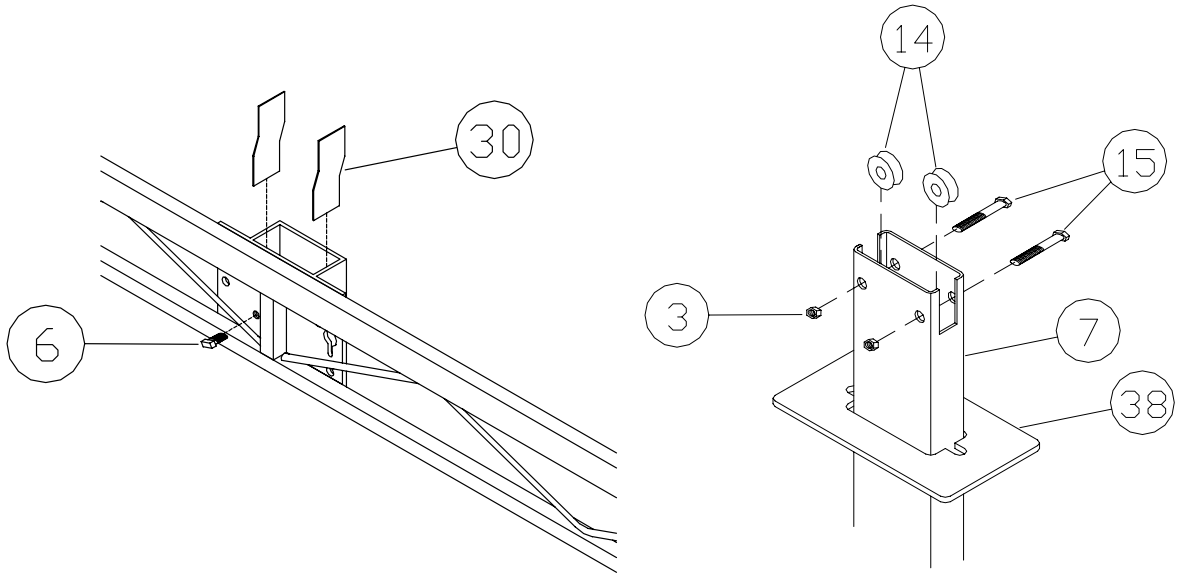

STEP 3. Attach the chains (**REF. # 16**) to the inside holes of the axle (**REF. # 10**) with a 3/8" x 3" bolt and nut (**REF. # 19 & 2**). Slide on the 3" washers (**REF. # 8**) then the dock wheels (**REF. # 4**) with the protruding hub to the outside onto the axle up to the chains, and then slide on the lift member brackets (**Ref. #13**). Place the 1/4" x 2 1/2" bolt (**Ref. #1**) into the holes in the ends of the axle and screw on the 1/4" acorn nut (**REF. # 1A**). Roll axle under dock, keeping axle centered with dock. Bolt lift member bracket (**Ref. #13**) to vertical lift members (**Ref. #7**) with 3/8" x 3" bolts and nuts (**Ref. #19 & 2**).

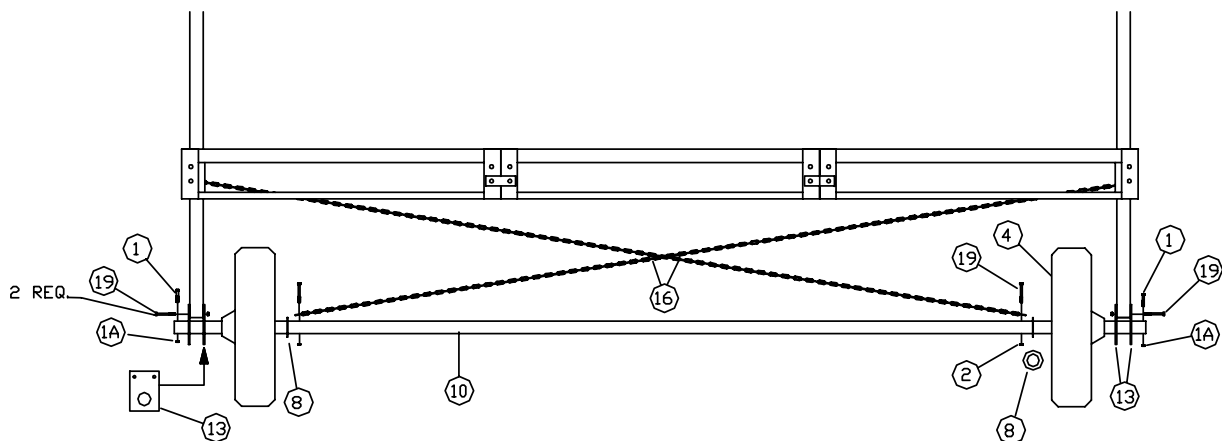

STEP 4. Bolt on winch handles (**Ref. #28**) with winch nut (**Ref. #29**). Attach lower dock pulleys (**Ref. #14**) to the winch side of the dock pockets with 1/2" x 2 3/4" pin between pocket and ear tab. Starting winch cable (**REF. # 12**) from the outside of the winch, pass cable through the hole on the side of the drum with the gears. Run cable through lower pulley, then up to pulleys on vertical lift members, and down to holes on opposite side of pocket. Fasten with 3/16" cable clamp (**REF. # 5**). Work winches until cables are raising dock. You must alternate winches as the dock moves up or down. Place VLM pulley cover (**Ref. #23**) onto the vertical lift member.

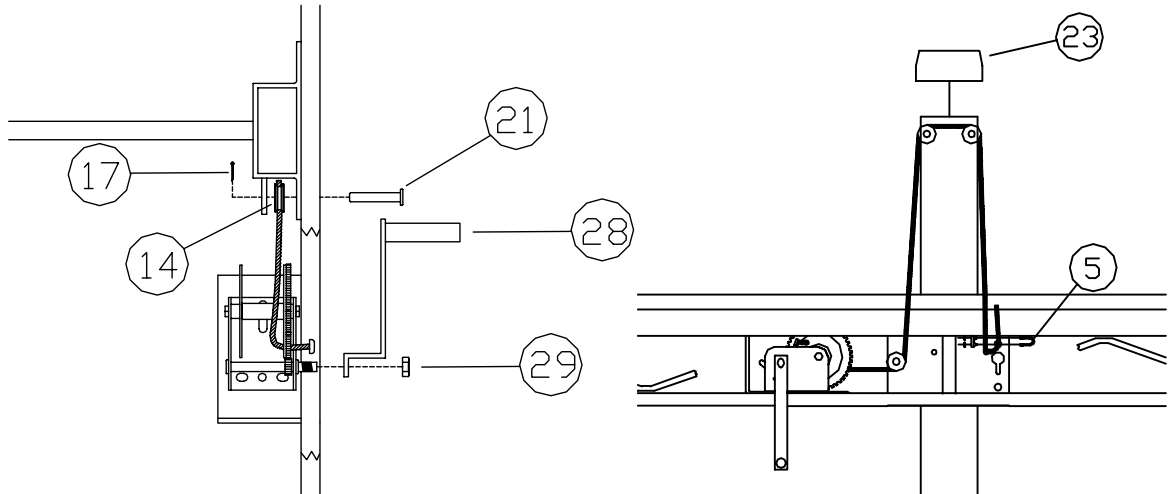

STEP 5. Raise dock high enough to be able to work on it.

CAUTION: Before working under dock, be sure that the winches are locked and the set screws are tight.

Bring top of chain (**REF. # 16**) up to the opposite side of dock, through the keyhole bracket, located on the vertical lift member pocket and lock in position by sliding the chain link down the keyhole slot. If assembling an AA dock, bolt the center of the 8' section to the inside pocket of the 16' section using 1/2" x 2 1/2" bolts and nuts (**Ref. #15 & 3**).

NOTE: If further adjustment of dock height is necessary loosen chains and set screws before adjusting.

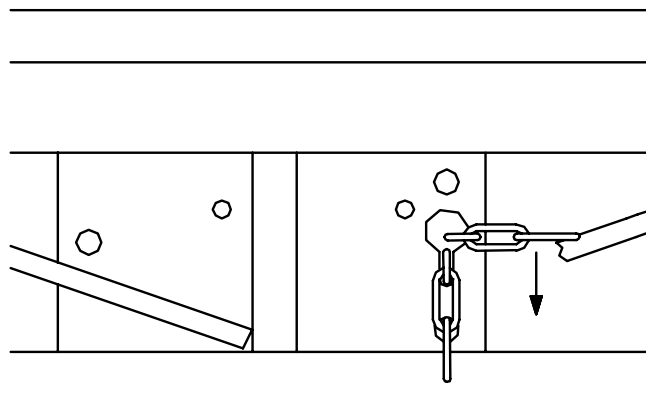

STEP 6 Attaching the truss, turn the truss bar (**Ref. #1**) so that the end with the two holes is toward the 16' section. Place the truss bar underneath the docks frame so that is about 16" in front of the vertical lift member.

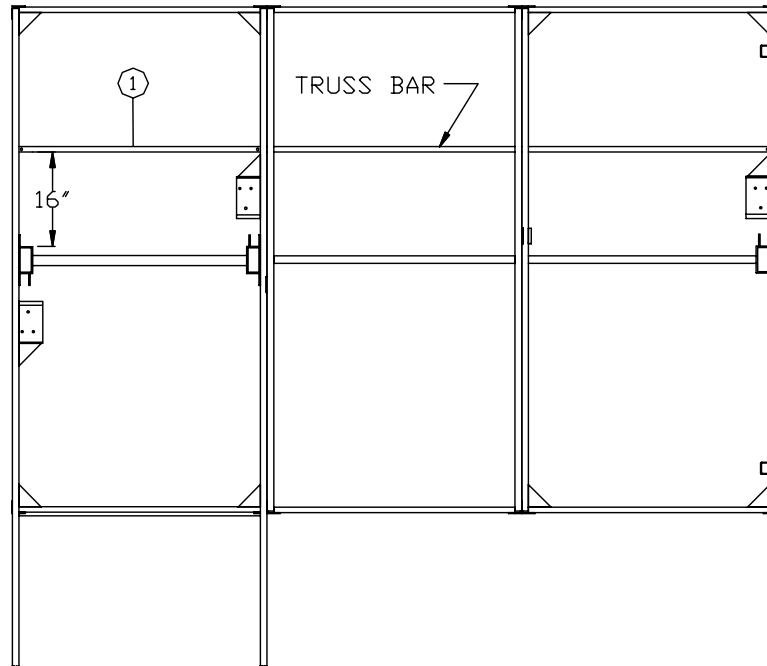

STEP 7. Fasten truss bar to the bottom one-inch square tube of the docks frame with the three J-hooks, 5/16" washers and lock nuts (**REF. # 2, 3 & 4**) as shown.

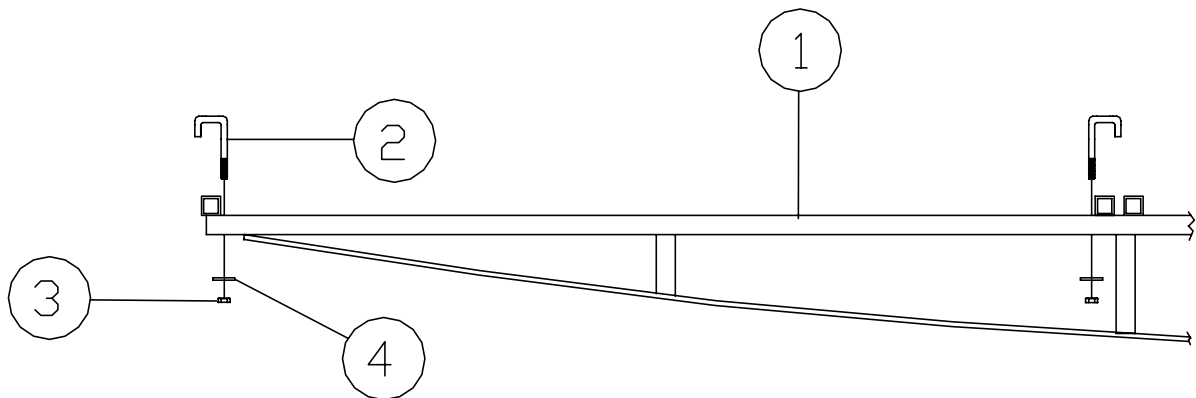

NOTE:

After the panels are installed on the dock, slide a cover plate (**Ref. #37**) down each dock post and onto the deck. Place a rectangular post cap (**Ref. #25**) onto each post.

Your dock is now ready to move into the water and be adjusted to the desirable height. When dock is at desired height, chains should be tight. If the chains are not tight, lower dock 3" to 4" and tighten chains. Raise the dock back to the desired height and re-check tightness of the chains.

AD15- DS 4'X 16'L12-AA / AP15- DS 4'X 16'L12-APD
AW15- 4'X 16'L12-CPD ALUMINUM PORTA-DOCK

REF. #	PART NO.	DESCRIPTION	QUANTITY		
			APD	CPD	AA
1	5153	1/4" x 2 1/2" BOLT	2	2	2
1A	5041	1/4" ACORN NUT	2	2	2
2	5056	3/8" NUT	12	12	12
3	5058	1/2" NUT	24	24	24
4	4002	TIRE PLASTIC MOLDED	2	2	2
5	5003	3/16" CABLE CLAMP	2	2	2
6	5170	1/2" X 3/4" SET SCREW	4	4	4
7	30084	VERTICAL LIFT MEMBER	2	2	2
8	5077	3" WASHER	2	2	2
9	10200	DOCK CONNECTOR BRACKET	4	4	4
10	30082	AXLE FOR APD, RPD	1	1	-
10	30089	AXLE FOR AA	-	-	1
11	3005	WINCH DL1100	2	2	2
12	3050	CABLE 3/16" X 15'	2	2	2
13	30088	LIFT MEMBER BRACKET	4	4	4
14	3300	PULLEY SHEAVE 1 1/2"	6	6	6
15	5120	1/2" X 2 1/2" BOLT	8	8	8
16	3070	CHAIN 3/16" X 13'	2	2	2
17	5025	1/8" X 1" COTTER PIN	2	2	2
18	5081	3/8" X 1" BOLT	6	6	6
19	5084	3/8" X 3" BOLT	6	6	6
20	5126	1/2" X 1 1/4" BOLT	16	16	16
21	5008	1/2" X 2 3/4" PIN	2	2	2
23	3804	VLM PULLEY COVER	2	2	2
24	C30	8'ALUMINUM DOCK POST	2	2	2
25	3803	RECTANGULAR POST CAP	2	2	2
28	3008	DL WINCH HANDLE	2	2	2
29	5066	DL WINCH NUT	2	2	2
33	4112	8 1/2" VLM WEAR PAD	4	4	4
34	4108	FOAM TAPE- 16' ROLL	7	-	-
36	5069	7/16" WASHER	32	32	32
37	3840	COVER PLATE APD WHITE	2	-	-
	3845	COVER PLATE APD BEIGE	2	-	-
	3841	COVER PLATE CPD BROWN	-	2	-
38	C120	AA VLM COVER PLATE PKG	-	-	1
	3850	VLM COVER PLATE APD WHITE	2	-	-
	3851	VLM COVER PLATE APD BEIGE	2	-	-
	3852	VLM COVER PLATE CPD BROWN	-	2	-

TRUSS BAR

REF. #	PART NO.	DESCRIPTION	APD	CPD	AA
1	F63	APD, CPD TRUSS BAR	1	1	-
	F64	AA TRUSS BAR	-	-	1
2	5031	5/16" J-BOLT	3	3	3
3	5068	5/16" WASHER	3	3	3
4	5054	5/16" NUT	3	3	3

FRAMES

REF. #	PART NO.	DESCRIPTION	APD	CPD	AA
	M60	4'X 16' APD/CPD WHEEL END	1	1	-
	M20	4'X 16' AA WHEEL END	-	-	1
	M70	4'X 8' APD/CPD L12 CENTER SECT.	1	1	-
	M27	4'X 8' AA L12 CENTER SECT.	-	-	1
	M69	4'X 8' APD/CPD L12 L SECT.	1	1	-
	M26	4'X 8' AA L12 L SECT.	-	-	1

PANELS

REF. #	PART NO.	DESCRIPTION	APD	CPD	AA
	B86 (B)	4'X 4' ALUM PL STRAIGHT	4	-	-
	B53	4'X 4' CEDAR PL STRAIGHT	-	4	-
	B90 (B)	4'X 4' ALUM PL RIGHT CUTOUT	1	-	-
	B77	4'X 4' CEDAR PL RIGHT CUTOUT	-	1	-
	B89 (B)	4'X 4' ALUM PL LEFT CUTOUT	1	-	-
	B76	4'X 4' CEDAR PL LEFT CUTOUT	-	1	-
	B91 (B)	4'X 4' ALUM PL RIGHT CUTOUT	1	-	-
	B79	4'X 4' CEDAR PL RIGHT CUTOUT	-	1	-
	B92 (B)	4'X 4' ALUM PL L12 LEFT CUTOUT	1	-	-
	B78	4'X 4' CEDAR PL L12LEFT CUTOUT	-	1	-

C120 AA COVER PLATE PKG

<u>PART #</u>	<u>DESCRIPTION</u>	<u>APD</u>	<u>CPD</u>	<u>AA</u>
5067	FENDER WASHER 3/8"	-	-	2
5150	CARRIAGE BOLT 1/4" X 3/4" GR 2	-	-	2
5055	NUT FIN 1/4"	-	-	2
10120	AA COVER PLATE 2.75" X 8" NEW '03	-	-	1

